

Fonos

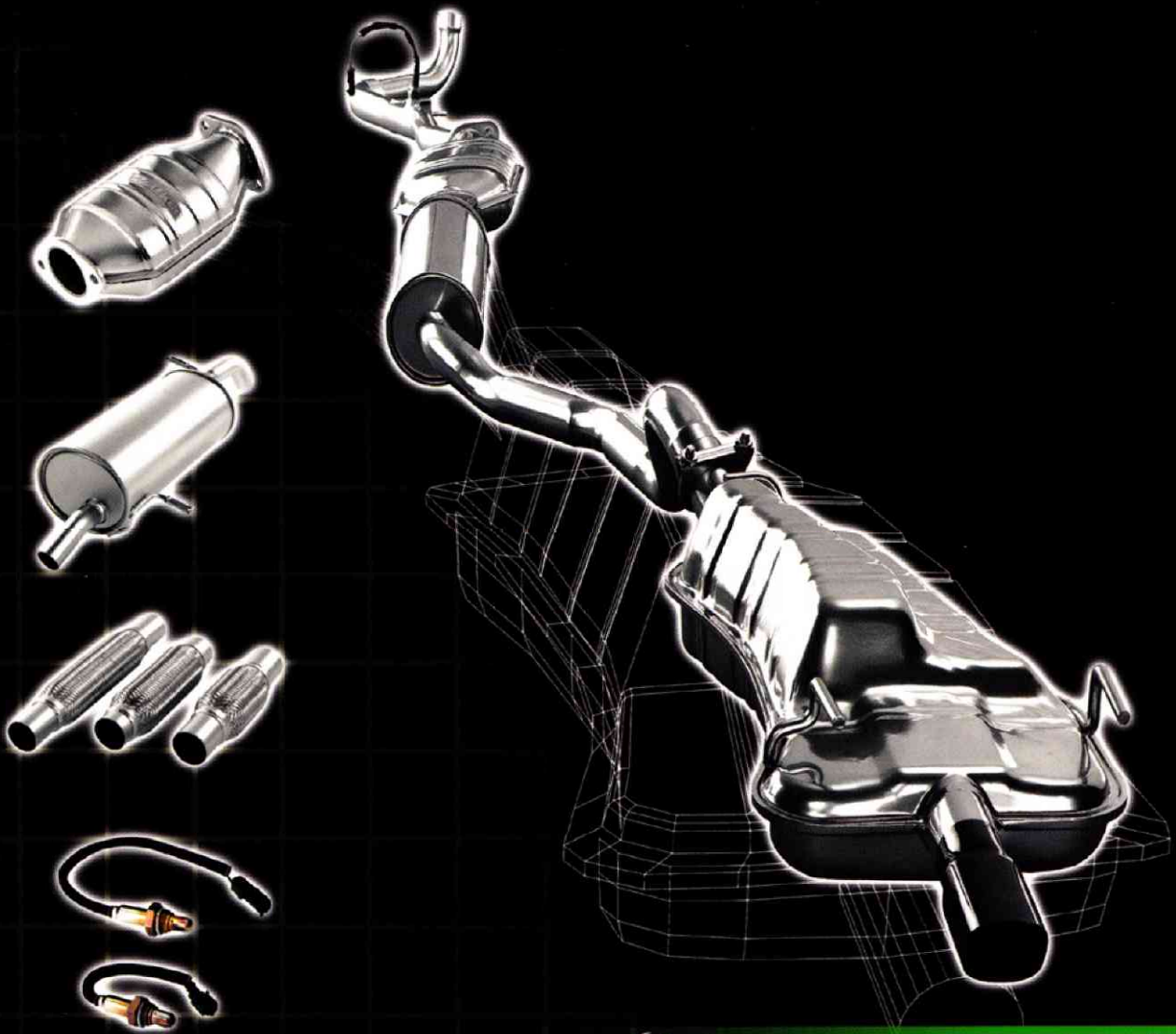

 **Juntos protegiendo el medio ambiente**



WALKER 

TENNECO

www.walker-eu.com

Fonor

Citroën

75527203 613206	AY1824 31321	AY1820 631332	75511211 31325		Acadiane 0.6 02/78-12/88 602 cc - 31 HP - 23 kW Type/Typ: AYU-AY serie CD TSN: 501
AM1821A N.D.(A)	AM1824B 6201025	AM1832A 613316	AM18293B 6601022		Ami 6 0.6 10/61-05/68 602 cc - 25 HP - 18 kW (A) -02/67 (B) 03/67-05/68 TSN: 323-329
N.D.(B) AM1821C					CI20005
75527203 613206	AY1824 31321	AY1820 631332	AZ182293A 31323 MK 85078		Ami 6 0.6 06/68-12/78 602 cc - 33 HP - 24 kW ⊕ : -07/69 Type/Typ: AM2-AMB2 TSN: 311-313
					CI20006
75527203 613206	AM1824C 6201032	AY1820 631332	AZ182293A 31323 MK 85078		Ami 8 0.6 03/69-12/78 602 cc - 35 HP - 26 kW Type/Typ: AM3-AMF3-AMFC3-AMJA-AMJB TSN: 301
					CI20007
	96635692 31367		96064421 61388 MK 85051		AX 10-E-RE, 11RE-TE-TGE-TRE-TRS Allure-Caban-First-KWay-Vogue 1.0, 1.1 10/86-07/92 954, 1124 cc - 45, 55 HP - 33, 40 kW Mot/Eng: TU9-TU1 Type/Typ: ZA serie ZA/ZAE/ZB/ZBI/ZH/ZJ/ZL/ZR/ZJ TSN: 452
					CI15001
96144090 N.D.	96014789 9718330CAT MK 18421		96067243 61306 MK 85018		AX 10E-Ten 1.0i 07/92-07/98 954 cc - 45, 50 HP - 33, 37 kW Mot/Eng: TU9M (Single Point Inj.) (A)= Repair Pipe Type/Typ: ZAZ*, ZAL* - TSN: 473 λ1=06/88-01/95 λ2=02/95-12/99
					CI15030

Los nombres y números de primer equipo se utilizan solamente como referencia

● En desarrollo

IMPORTANTE:

Al pedir sistemas de escape, rogamos completen la referencia comenzando por 'MFO.' (ejemplo: 381394 → MFO.381394)



Pour commander echappement, nous vous prions de compléter la référence en commençant par MFO..

When ordering exhaust, please complete the reference by beginning with MFO..

ESCAPE / ECHAPPEMENT / EXHAUST

Citroën

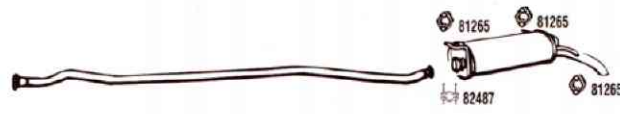
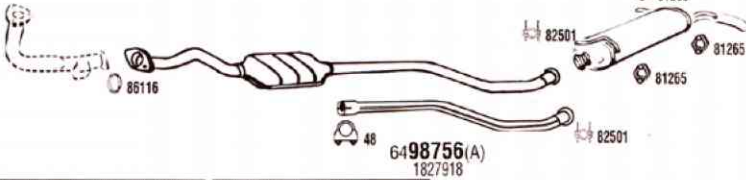
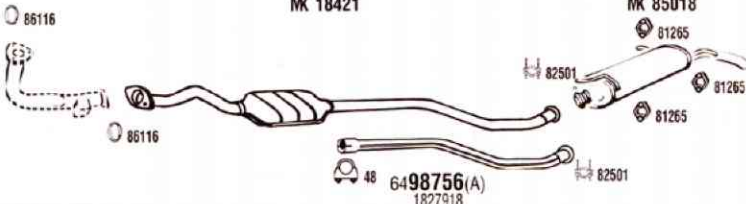
Fonos

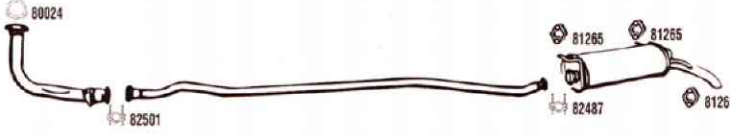
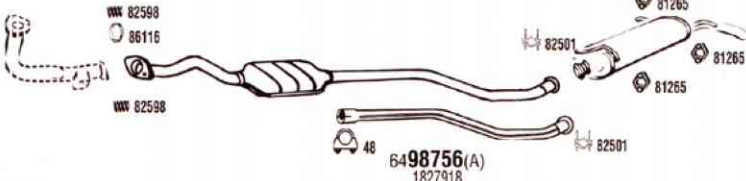
<p>AX 11RE - 11TRE 1.1 1987-07/92 1124 cc Mot/Eng: TU1 [3]-[5]</p>	<p>95631605 31387</p>	<p>96064421 61388 MK 85051</p> 
<p>CI15057 AX 11RE-TRE-TE-TGE-TRS 1.1 10/86-06/92 1124 cc - 55 HP - 40 kW Mot/Eng: TU1 (A)= Repair Pipe TSN: 452 λ¹=06/88->01/95 λ²=02/95->12/99</p>	<p>95639313 N.D.</p> <p>96014789 9718330CAT MK 18421</p>	<p>96067243 61306 MK 85018 81265</p>  <p>6498756(A) 1827918</p> <p>81265</p>
<p>CI15033 CAT AX 11 Club-First-Caban-Allure 1.1i 10/90-97 1124 cc - 60 HP - 44 kW Mot/Eng: TU1M (Single Point Inj.) (A)= Repair Pipe Type/Typ: ZA Serie DA/DAB/DB/DBB TSN: 483 λ¹=06/88->01/95 λ²=02/95->12/99</p>	<p>96133590 N.D.</p> <p>96014789 9718330CAT MK 18421</p>	<p>96067243 61306 MK 85018 81265</p>  <p>6498756(A) 1827918</p> <p>81265</p>
<p>CI15031 CAT AX 13 GT-Sport 1.3 03/87-05/91 1294 cc - 95 HP - 70 kW Mot/Eng: TU2-TU4 ch.no. (A) PR4071- Type/Typ: ZA serie ZL TSN: 462</p>	<p>96064974 N.D.(A)</p> <p>96021036 61305</p>	<p>96067243 61306 MK 85018 81265</p>  <p>81265</p>
<p>CI15008 AX 14 TRS-TZS 1.4 09/86-07/92 1361 cc - 70 HP - 51 kW Mot/Eng: TU3A ch.no. -PR5284 Type/Typ: ZA serie ZC/ZK TSN: 471</p>	<p>96054786 31389</p> <p>95631605 31390</p>	<p>96064421 61388 MK 85051 81265</p>  <p>81265</p>
<p>CI15015 AX 14 TRS-TZS-TZX 1.4 01/88-12/92 1360 cc - 60 HP - 44 kW Mot/Eng: TU3 (A) = Repair pipe TSN: 453 λ¹=06/88->01/95 λ²=02/95->12/99</p>	<p>95639314 N.D.</p> <p>96014789 9718330CAT MK 18421</p>	<p>96067243 61306 MK 85018 81265</p>  <p>6498756(A) 1827918</p> <p>81265</p>

● En desarrollo

Los nombres y números de primer equipo se utilizan solamente como referencia

IMPORTANTE:







Al pedir sistemas de escape, rogamos completen la referencia comenzando por 'MFO.' (ejemplo: 381394 → MFO.381394)

Pour commander echappement, nous vous prions de compléter la référence en commençant par MFO..

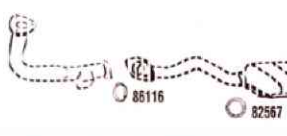
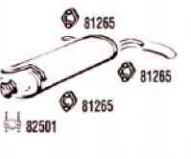
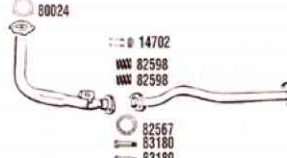
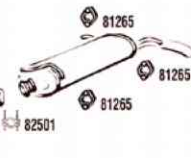
When ordering exhaust, please complete the reference by beginning with MFO..

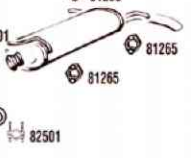
Fonos

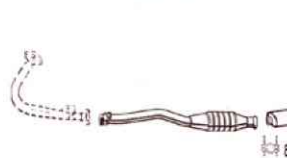
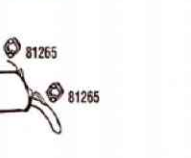
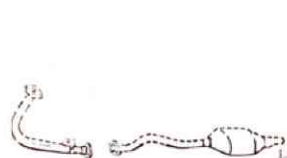
Citroën

<p>96014787 N.D.</p>  <p>86116 82567</p>	<p>N.D.CAT</p> <p>96067243 61306 MK 85018</p>  <p>81265 81265 81265 82501</p>	<p>AX 14 GT-Allure-Exclusive 1.4i 10/86-07/92 1360 cc - 75, 80 HP - 55, 59 kW Mot/Eng: TU3S TSN: 480 λ¹=06/86->07/92</p>
<p>87854 87910 87999x2</p> <p>95638423 31304</p>  <p>80024 14702 82598 82598 82567 83180 83180</p>	<p>96021036 61305</p> <p>96067243 61306 MK 85018</p>  <p>81265 81265 82501</p>	<p>AX 14 GT 1.4i 10/87-07/92 1361 cc - 85 HP - 63 kW Mot/Eng: TU3S Type/Typ: ZA serie ZD-ZA serie ZY TSN: 461</p>
<p>95639314 N.D.</p>  <p>82598 86116 82598</p>	<p>95014789 9718330CAT MK 18421</p> <p>96067243 61306 MK 85018</p>  <p>81265 81265 82501 82501 48 6498756(A) 1827918</p>	<p>AX 14 GT-Allure-Exclusive 1.4i 01/89-06/95 1360 cc - 75 HP - 55 kW Mot/Eng: TU3M (Single Point Inj.) (A)= Repair Pipe Type/Typ: ZA - TSN: 480 λ¹=06/88->01/96 λ²=02/95->12/99</p>
<p>87854 87910 87999x2 87854 87912</p> <p>96080424 N.D.</p>  <p>86116</p>	<p>96014789 9718330CAT MK 18421</p> <p>96067243 61306 MK 85018</p>  <p>81265 81265 82501 82501 48 6498756(A) 1827918</p>	<p>AX 14 GT-Allure-Exclusive 1.4i 01/92-06/95 1360 cc - 75 HP - 55 kW Mot/Eng: TU3M (Single Point Inj.) (A)= Repair Pipe Type/Typ: ZA Serie DD/DB/DE/ADEB TSN: 480 λ¹=06/88->01/95 λ²=02/95->12/99</p>
<p>87854 87910 87999x2 87854 87912</p> <p>96105224 N.D.</p>  <p>9220295CAT MK 87172</p>	<p>96092273 6517531</p> <p>96092280 5217535 MK 85018</p>  <p>81265 81265 81265 82501 82501</p>	<p>AX 1.4 GTi 08/91-06/95 1360 cc - 94 HP - 69 kW Mot/Eng: TU3J2 (Multi Point Inj.) Type/Typ: ZA Serie DM TSN: 215, 207</p>
<p>87854 87910</p> <p>N.D. N.D.CAT</p> 	<p>96092273 6517531</p> <p>96067243 61306 MK 85018</p>  <p>81265 81265 81265 82501 82501</p>	<p>AX 1.4 GTi 04/91-12/91 1360 cc - 98 HP - 72 kW Mot/Eng: TU3M Type/Typ: ZA Serie L</p>
<p>87854 87910 87999x2</p>	<p>96092273 6517531</p>	<p>AX 1.4 GTi 04/91-12/91 1360 cc - 98 HP - 72 kW Mot/Eng: TU3M Type/Typ: ZA Serie L</p>

Los nombres y números de primer equipo se utilizan solamente como referencia

● En desarrollo

IMPORTANTE:

Al pedir sistemas de escape, rogamos completen la referencia comenzando por 'MFO.' (ejemplo: 381394 → MFO.381394)

Pour commander echappement, nous vous prions de compléter la référence en commençant par MFO..

When ordering exhaust, please complete the reference by beginning with MFO..

ESCAPE / ECHAPPEMENT / EXHAUST

Citroën

Fonos

AX
1.4 GTi
05/91-06/92
1360 cc - 100 HP - 74 kW
Mot/Eng: TU3FJ2/K
Type/Typ: ZA serie DN

96097865 6117168	96092272 6717534	96092280 5217535 MK 85018
----------------------------	----------------------------	--

CI15027 7317536

AX
D-RD-TRD-TGD
Allure-Caban-Ten
1.4 Diesel
10/88-06/95
1361 cc - 53 HP - 39 kW
Mot/Eng: TUD3
Ⓢ: -06/92
Type/Typ: ZA serie ZU/ZT
TSN: 472

96003913 31371	96021036 61305	96067243 61306 MK 85018
--------------------------	--------------------------	--------------------------------------

CI15009 7314031

AX
First
1.4 Diesel
03/89-96
1360 cc - 50 HP - 37 kW
Mot/Eng: TUD3
TSN: 216

96003913 31371	96144091 N.D.CAT	96067243 61306 MK 85018
--------------------------	----------------------------	--------------------------------------

CI15029 **CAT** 7317532

AX
X - SX - VSX - Millesime
1.5 Diesel
04/94-97
1527 cc - 58 HP - 43 kW
Mot/Eng: TUD5
Type/Typ: ZA-KE (3DR) & ZA-KF(5DR)
TSN: 270

1705 93 6205322	96021036 61305	96067243 61306 MK 85018
---------------------------	--------------------------	--------------------------------------

CI15019 7314031

Axel
11R-12TRS
1.1, 1.3
07/84-06/90
1129, 1299 cc - 57, 62 HP - 42, 46 kW
Made in Rumania
Type/Typ: TA serie TB/TF/TH/TJ

95538707 6608379	95538685 5308380 MK 85121
----------------------------	--

CI50111 7312801

Berlingo
MPV,Box
1.1 i
07/96-
1124 cc - 60 HP - 44 kW
Mot/Eng: HDZ (TU1M)
Type/Typ: MF,MB

1705 A8 6221807 MK 85288	1731 21 9220096CAT MK 21646	1717 74 613866 MK 85405	1726 N6 613993 MK 85016
---------------------------------------	--	--------------------------------------	--------------------------------------











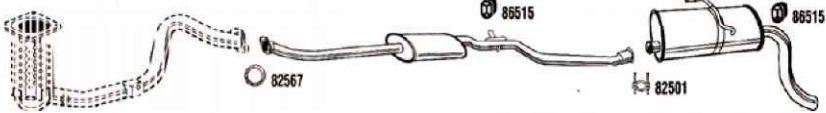

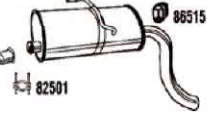

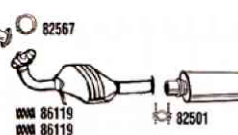

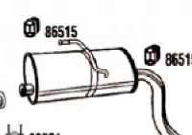
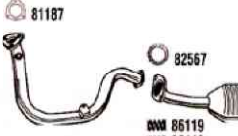
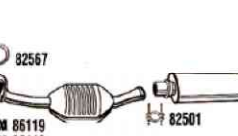

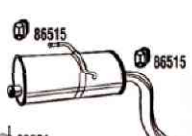
CIW13040 **CAT** 7312801

● En desarrollo

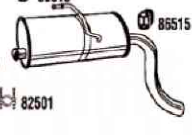
Los nombres y números de primer equipo se utilizan solamente como referencia

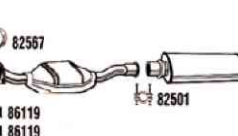
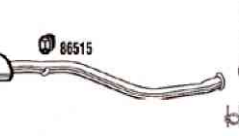
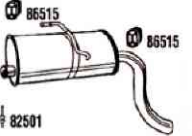
IMPORTANTE:

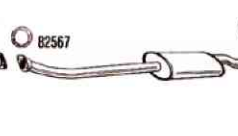
Al pedir sistemas de escape, rogamos completen la referencia comenzando por 'MFO.' (ejemplo: 381394 → MFO.381394)
Pour commander echappement, nous vous prions de compléter la référence en commençant par MFO..
When ordering exhaust, please complete the reference by beginning with MFO..

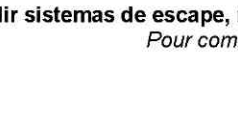
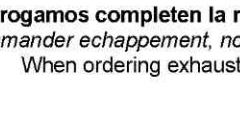
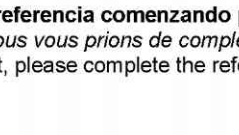
<p>1731P1 N.D.CAT</p> 	<p>1717 N0 613498(A)</p> 	<p>1726 N6 613993(A) MK 85016</p> 	<p>Berlingo MPV, Box 1.1 i 07/96- 1124 cc - 60 HP - 44 kW Mot/Eng: HFX (TU1JP) To: (A) -12/02 From: (B) 12/02-</p>	
<p>1705 C0 6221811 MK 85288</p> 	<p>1731 21 9220096CAT MK 21646</p> 	<p>N.D.(B) 1717T5 1717 74 613866 MK 85405</p> 	<p>N.D.(B) 1726Q1 1726 N6 613993 MK 85016</p> 	<p>CIW13041 CAT Berlingo MPV, Box 1.4 i 07/96-10/97 1360 cc - 75 HP - 55 kW Mot/Eng: KFX (TU3JP) Type/Typ: M (MFKFX, MBKFX) λ = Daprot EURO93/CEE W2 λ = Daprot 15-04 Emission: Euro 96</p>
<p>λ 1 87854 87912</p> <p>1705 V8 6221808 MK 85288</p> 	<p>λ 2 87854 87919</p> <p>1731 95 9220255CAT MK 87173</p> 	<p>1717 74 613866 MK 85405</p> 	<p>1726 N6 613993 MK 85016</p> 	<p>CIW13042 CAT Berlingo MPV, Box 1.4 i 10/97-12/02 1360 cc - 75 HP - 55 kW Mot/Eng: KFX (TU3JP) Type/Typ: M (MFKFX, MBKFX) Emission: Euro 96</p>
<p>1705 48 313110(A) MK 85288</p> 	<p>1717-92 6221858(A) MK 85451</p> 	<p>1717 74 613866 MK 85405</p> 	<p>1726 N6 613993 MK 85016</p> 	<p>CIW13043 CAT Berlingo MPV, Box 1.4 07/96-12/02 1360 cc - 70 HP - 52 kW Mot/Eng: K5A (TU3.2) Type/Typ: M To: (A) -09/97 From: (B) 09/97-</p>
<p>MK 85288 6221812(B) 1705 V9</p> 	<p>MK 85451 6221859(B) 1717 90</p> 	<p>1717 74 613866 MK 85405</p> 	<p>1726 N6 613993 MK 85016</p> 	<p>CIW13044 CAT Berlingo MPV, Box 1.4 i 07/96-12/02 1360 cc - 75 HP - 55 kW Mot/Eng: KFX (TU3JP) Type/Typ: M (MFKFX) Emission: Euro 2000</p>
<p>1705 Y9 6221809 MK 85288</p> 	<p>1731 E2 9220216CAT</p> 	<p>1717 74 613866 MK 85405</p> 	<p>1726 N6 613993 MK 85016</p> 	<p>CIW13045 CAT Berlingo MPV, Box 1.4 i 07/96-12/02 1360 cc - 75 HP - 55 kW Mot/Eng: KFW (TU3JP) Type/Typ: M (MFKFX, MBKFX)</p>
<p>1731 L8 9220649CAT</p> 	<p>1717 N0 613498</p> 	<p>1726 N6 613993 MK 85016</p> 	<p>CIW13046 CAT Berlingo MPV, Box 1.4 i 07/96-12/02 1360 cc - 75 HP - 55 kW Mot/Eng: KFW (TU3JP) Type/Typ: M (MFKFX, MBKFX)</p>	

Los nombres y números de primer equipo se utilizan solamente como referencia

● En desarrollo

IMPORTANTE:

Al pedir sistemas de escape, rogamos completen la referencia comenzando por 'MFO.' (ejemplo: 381394 → MFO.381394)

Pour commander echappement, nous vous prions de compléter la référence en commençant par MFO..

When ordering exhaust, please complete the reference by beginning with MFO..

ESCAPE / ECHAPPEMENT / EXHAUST

Fonos

Citroën

Berlingo
MPV, Box
 1.4 i
12/02-
 1360 cc - 75 HP - 55 kW
 Mot/Eng: KFW (TU3JP)
 Type/Typ: M (MFKFX,MBKFX)

1731 L8
 9220649CAT

171775
 N.D.

1726QT
 N.D.



CIW13047 **CAT**

Berlingo
MPV, Box
 1.4 i bivalent
04/03-
 1360 cc - 75 HP - 55 kW
 Type/Typ: M

1731 L8
 9220649CAT

171775
 N.D.

1726QT
 N.D.



CIW13048 **CAT**

Berlingo
MPV, Box
 1.6 16v
10/00-
 1587 cc - 109 HP - 80 kW
 Mot/Eng: NFU (TU5JP4)
 Type/Typ: M (MNFU)
 To:(A) -12/02 - From:(B) 12/02-

1731GV
 N.D.CAT

1717 N0
 613498(A)

1726 N6
 613993(A)
 MK 85016

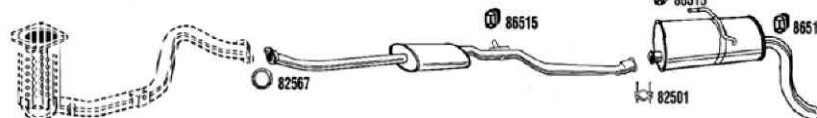

CIW13049 **CAT**

Berlingo
MPV, Box
 1.8 i
05/97-
 1761 cc - 90 HP - 66 kW
 Mot/Eng: LFX (XU7JB)
 Type/Typ: M (MFLFX)

1705 T8
 9320297CAT
 MK 21826

N.D.(B)
 171775

1717 74
 613866
 MK 85405

N.D.(B)
 1726QT

1726 N6
 613993
 MK 85016

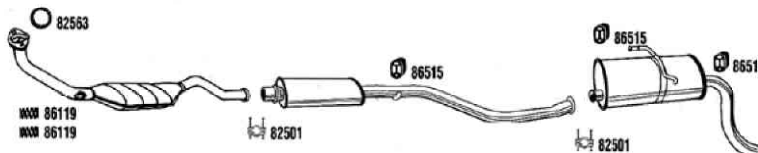

CIW13050 **CAT**

Berlingo
MPV, Box
 1.8 Diesel
07/96-
 1769 cc - 59 HP - 43 kW
 Mot/Eng: A9A (XUD7)
 Type/Typ: M (MCA9A,MFA9A)

1721 28
 613509

1705 P2
 613865
 MK 85558

1726 N6
 613993
 MK 85016

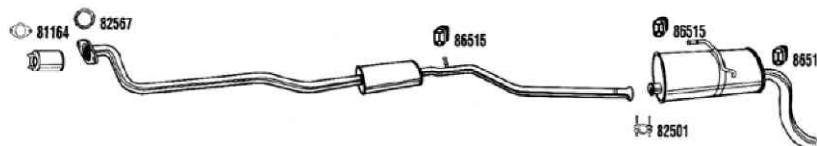

CIW13051

Berlingo
MPV, Box
 1.9 Diesel
07/96-
 1905 cc - 68 HP - 50 kW
 Mot/Eng: D9B (XUD9A/L), DJY (XUD9A)
 Type/Typ: M (MFDJY)
 (A) repair pipe

1705 P4
 9820309CAT
 MK 87234

1726 N6
 613993
 MK 85016
 MK 86515

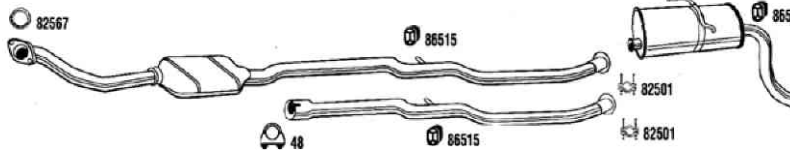

CIW13052 **CAT**

6607581(A)
 1705P4SP22

● En desarrollo

Los nombres y números de primer equipo se utilizan solamente como referencia

IMPORTANTE:

Al pedir sistemas de escape, rogamos completen la referencia comenzando por 'MFO.' (ejemplo: 381394 → MFO.381394)

Pour commander echappement, nous vous prions de compléter la référence en commençant par MFO..

When ordering exhaust, please complete the reference by beginning with MFO..

1705 AC 9820316CAT MK 87233	1726 N6 613993 MK 85016
-----------------------------------	-------------------------------

6607581(A)
1705P4SP22

Berlingo
MPV, Box
1.9 Diesel
07/98-
1868 cc - 70 HP - 51 kW
Mot/Eng: WJZ (DW8)
Type/Typ: M (MFWJZ, MBWJZ)
(A) repair pipe

CIW13053 **CAT**

1705 LW 613756(A)	1731 N8 9220616CAT	1726 N6 613993 MK 85016
----------------------	-----------------------	-------------------------------

613842(B)
1705PS

6307953(C)
1731T9SP22

Berlingo
MPV, Box
1.9 Diesel
07/98-12/02
1868 cc - 70 HP - 51 kW
Mot/Eng: WJY (DW8B)
Type/Typ: M (MFWJZ, MBWJZ)
To: (A) - 11/01
From: (B) 11/01-
(C) repair pipe

CIW13054 **CAT**

1705QN N.D.	1731Y1 9620655CAT	1705QS N.D.
----------------	----------------------	----------------

Berlingo
MPV, Box
1.9 Diesel
12/02-
1868 cc - 70 HP - 51 kW
Mot/Eng: WJY (DW8B)
Type/Typ: M (MFWJZ, MBWJZ)

CIW13055 **CAT**

1705 EZ 9220589CAT(A)	1717 H1 615394	1726 GN 615393(C) MK 85931
--------------------------	-------------------	----------------------------------

9220657CAT(B)
1705NH

N.D.(D)
1726VG

Berlingo
MPV, Box
2.0 HDi
12/99-02/04
1997 cc - 90 HP - 66 kW
Mot/Eng: RHY (DW10TD)
Type/Typ: M (MFRHY, MBRHY)
Emission: (A) Euro II
Emission: (B) Euro III
(C) - 12/02
(D) 12/02-

CIW13056 **CAT**

95588568 31360	95606302 N.D.	95576335 N.D.	96046472 N.D.
-------------------	------------------	------------------	------------------

BX Altern.
11E-RE
1.1
10/82-06/83
1124 cc - 62 HP - 45 kW
Mot/Eng: TU1
Type/Typ: XB serie XA/XD

CI61052

95588568 31360	95588569 31361	95588570 61362 MK 85675	96046471 61363 MK 85029
-------------------	-------------------	-------------------------------	-------------------------------

BX
11E-RE
1.1
07/83-05/88
1124 cc - 62 HP - 45 kW
Mot/Eng: TU1
Type/Typ: XB serie XA/XD

7301205 CI61053

Los nombres y números de primer equipo se utilizan solamente como referencia ● En desarrollo

IMPORTANTE:

Al pedir sistemas de escape, rogamos completen la referencia comenzando por 'MFO.' (ejemplo: 381394 → MFO.381394)
 Pour commander echappement, nous vous prions de compléter la référence en commençant par MFO..
 When ordering exhaust, please complete the reference by beginning with MFO..

ESCAPE / ECHAPPEMENT / EXHAUST

Citroën

BX
11E-RE-TE-TGE
1.1
06/88-10/91
1124 cc - 62 HP - 46 kW
Mot/Eng: TU1
ch.no. PR4196-
Type/Typ: XB serie ER/ERT

96012916
6213694

96012918
6713695

95588570
61362
MK 85675

96046471
61363
MK 85029

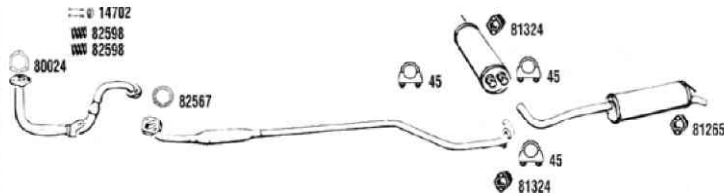

7313696

CI61054
BX
11E-RE-TE-TGE 
1.1
06/88-10/91
1124 cc - 62 HP - 46 kW
Mot/Eng: TU1
ch.no. PR4196-
Type/Typ: XB serie ES/EST

96012916
6213694

96012918
6713695

95588570
61362
MK 85675

96046482
61346
MK 85029

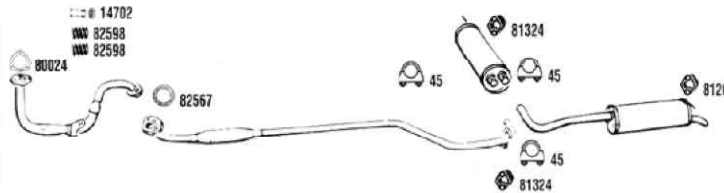

7313696

CI61055
BX Altern.
14E-14RE
1.4
10/82-06/83
1360 cc - 62, 72 HP - 46, 53 kW
Mot/Eng: 150A, 150C
Type/Typ: X3 serie XA/XD
TSN: 407-410

95588568
31360

95606302
N.D.

95576335
N.D.

96046472
N.D.

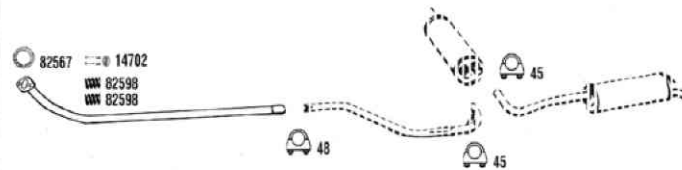

7301205

CI61051
BX
14E-14RE
1.4
07/83-06/88
1361 cc - 72 HP - 53 kW
Mot/Eng: 150A, 150C
Type/Typ: X3 serie XA/XD
TSN: 407-410-411

95588568
31360

95688569
31361

95588570
61362
MK 85675

96046471
61363
MK 85029

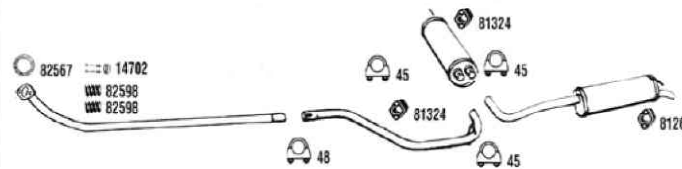

7301205

CI61014
BX
14 E-14 RE-Selection
1.4
07/83-07/88
1360 cc - 55 HP - 40 kW
ch.no. - PR4195

N.D.CAT

95688569
31361

95588570
61362
MK 85675

96046471
61363
MK 85029

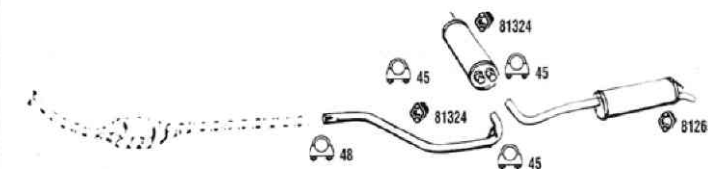

7313696

CI61005 **CAT**
BX
14E-RE-TE-GTE
1.4
06/88-12/92
1361 cc - 72 HP - 53 kW
Mot/Eng: TU3A
ch.no. 4196-
Type/Typ: XB serie ER/ERT
TSN: 411, 407

87854 87910 87999

96012916
6213694

96012918
6713695

95588570
61362
MK 85675

96046471
61363
MK 85029

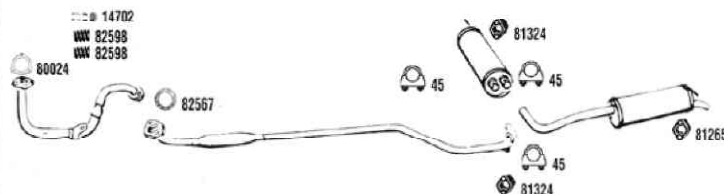

7313696

● En desarrollo

Los nombres y números de primer equipo se utilizan solamente como referencia

IMPORTANTE:

Al pedir sistemas de escape, rogamos completen la referencia comenzando por 'MFO.' (ejemplo: 381394 → MFO.381394)

Pour commander echappement, nous vous prions de compléter la référence en commençant par MFO..

When ordering exhaust, please complete the reference by beginning with MFO..

Fonos

Citroën

96022545 N.D.	96043453 N.D.CAT	95588569 31361	95588570 61362 MK 85675	96046471 61363 MK 85029
------------------	---------------------	-------------------	-------------------------------	-------------------------------

BX
14E-RE-TE-GTE
1.4
07/88-01/90
1360 cc - 75 HP - 55 kW
Mot/Eng: TU3
ch.no. PR4223-
Type/Typ: XB
TSN: 479

A1 87854 87910 87999			95588569 31361	95588570 61362 MK 85675	96046471 61363 MK 85029
N.D.	N.D.CAT				

CI61007 **CAT**

BX
14E-14RE
1.4
07/88-01/90
1360 cc - 75 HP - 55 kW
Mot/Eng: TU
ch.no. PR4329-

A1 87854 87910 87999			95588569 31361	95588570 61362 MK 85675	96046471 61363 MK 85029
96022545 N.D.	96022544 N.D.CAT				

CI61008 **CAT**

BX
14E-RE-TE
1.4
09/88-09/94
1360 cc - 75 HP - 55 kW
Mot/Eng: TU3
ch.no. PR4329-
Type/Typ: XB

A1 87854 87910 87999		95588568 31360	95588569 31361	95588570 61362 MK 85675	96046482 61346 MK 85029
96022545 N.D.					

CI61058 **CAT**

BX
14E-RE-TE-GTE 
1.4
10/82-06/88
1361 cc - 72 HP - 53 kW
Mot/Eng: 150 C
ch.no. -PR4195
Type/Typ: XB serie XY

95632595 N.D.CAT	95588569 31361	95588570 61362 MK 85675	96046482 61346 MK 85029
---------------------	-------------------	-------------------------------	-------------------------------

7301205 CI61016

BX
14E-14RE 
1.4
07/83-07/88
1360 cc - 72 HP - 53 kW
ch.no. - PR 4195

A1 87854 87910 87999		96012916 6213694	96012918 6713695	95588570 61362 MK 85675	96046482 61346 MK 85029

CI61006 **CAT**

BX
14E-RE-TE-TGE 
1.4
06/88-12/92
1361 cc - 72 HP - 53 kW
Mot/Eng: TU3A
ch.no. PR4196-
Type/Typ: XB serie ES/EST/XR

Los nombres y números de primer equipo se utilizan solamente como referencia ● En desarrollo

IMPORTANTE:

Al pedir sistemas de escape, rogamos completen la referencia comenzando por 'MFO.' (ejemplo: 381394 → MFO.381394)
 Pour commander echappement, nous vous prions de compléter la référence en commençant par MFO..
 When ordering exhaust, please complete the reference by beginning with MFO..

ESCAPE / ECHAPPEMENT / EXHAUST

Fonos

MOTOR / MOTEUR / ENGINE

Citroën

BX
14E-RE-TE-GTE

1.4
07/88-01/90
1360 cc - 75 HP - 55 kW
Mot/Eng: TU3
ch.no. PR4223-
Type/Typ: XB

96012916
6213694 N.D.CAT 95588569 **31361** 95588570 **61362** 96046482 **61346**
MK 85675 MK 85029

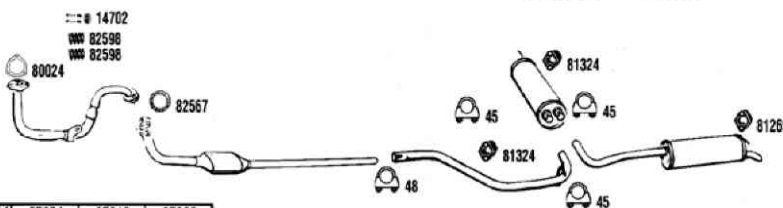

CI61056 **CAT**

A1 87854 87910 87999

BX
14E-RE-TE-GTE

1.4
09/88-09/94
1360 cc - 72 HP - 52 kW
Mot/Eng: TU3
ch.no. PR4329-
Type/Typ: XB

96022545 N.D. 96022544 N.D.CAT 95588569 **31361** 95588570 **61362** 96046482 **61346**
MK 85675 MK 85029

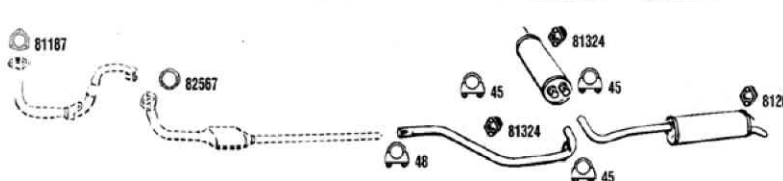

CI61057 **CAT**

A1 87854 87910 87999

BX
15RE, 16S-RS-TRS

1.5, 1.6
07/84-12/92
1549, 1580 cc - 80, 94 HP - 59, 69 kW
Mot/Eng: 89A-171C
14700 = 82563 + 82598 (2)
Type/Typ: XB serie XB/EE/XBT
TSN: 408-413

96076275 **31359** 95588569 **31361** 95588570 **61362** 96046471 **61363**
MK 85675 MK 85029

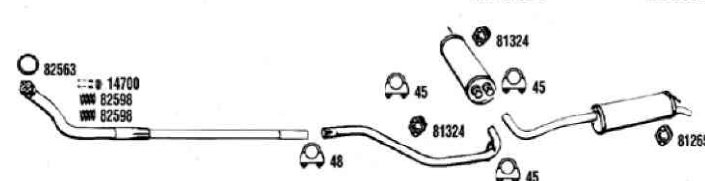

7315445

CI61018

BX
16RS-TRS

1.6
10/82-07/83
1580 cc - 90 HP - 66 kW
Type/Typ: XB serie XB
TSN: 408

1721 28 **613509** 95587261 N.D. 95576343 N.D. 95588570 **61362** 96046471 **61363**
MK 85675 MK 85029

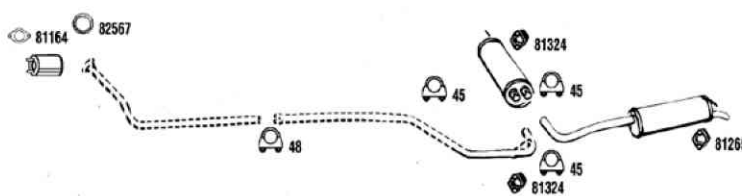

CI61011

BX
16RS-TRS

1.6
07/83-07/84
1580 cc - 93 HP - 68 kW
Mot/Eng: XU5
ch.no. -PR2944
Type/Typ: XB serie XB
TSN: 408

95600643 **1368** 95588510 **31369** 95588569 **31361** 95588570 **61362** 96046471 **61363**
MK 85675 MK 85029

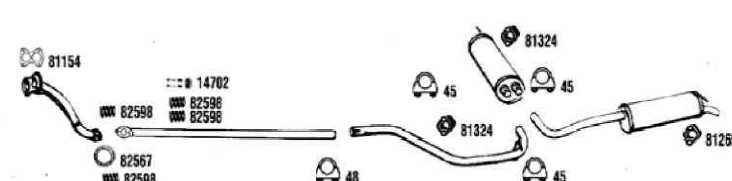

7301206

CI61012

BX
16Tri

1.6i
07/86-12/92
1580 cc - 103 HP - 76 kW
Mot/Eng: XU5
14700 = 82563 + 82598 (2)
Type/Typ: XB serie XB/EE/XBT
TSN: 442

95632640 **61391** 95634349 **31392** 95650909 **61393** 96048418 **61394**
MK 85839 MK 85047

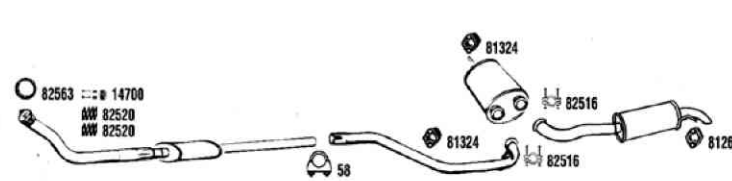

7312803

CI61061

● En desarrollo

Los nombres y números de primer equipo se utilizan solamente como referencia

IMPORTANTE:

Al pedir sistemas de escape, rogamos completen la referencia comenzando por 'MFO.' (ejemplo: 381394 → MFO.381394)

Pour commander echappement, nous vous prions de compléter la référence en commençant par MFO..

When ordering exhaust, please complete the reference by beginning with MFO..

96016570 9619139CAT	95634349 31392	95650909 61393 MK 85839	96048418 61394 MK 85047
------------------------	-------------------	-------------------------------	-------------------------------

7317160

BX
16RE-TGi-Tzi-Tri-Image-Millésime
 1.6i
01/87-12/92
 1580 cc - 88, 103 HP - 65, 76 kW
 Mot/Eng: XU5M3/L
 Type/Typ: XB
 TSN: 487

95600643 1368	95588510 31369	95588569 31361	95588570 61362 MK 85675	96046482 61346 MK 85029
------------------	-------------------	-------------------	-------------------------------	-------------------------------

7301206

BX
16S-RS
 1.6
07/83-06/85
 1580 cc - 90 HP - 66 kW
 Mot/Eng: XU5
 Type/Typ: XB serie XXH

95632594 N.D.CAT	95634349 31392	95650909 61393 MK 85839	96048419 613697 MK 85047
---------------------	-------------------	-------------------------------	--------------------------------

7317160

BX
16-S-RS-TRS-TGS
 1.6
11/84-12/89
 1580 cc - 89 HP - 65 kW
 Mot/Eng: BDZ
 Type/Typ: XB Serie XE/XH
 TSN: 488

96076275 31359	95588569 31361	95588570 61362 MK 85675	96046482 61346 MK 85029
-------------------	-------------------	-------------------------------	-------------------------------

7315445

BX
16S-RS-TRS-TR-Evasion
 1.6i
07/85-12/92
 1580 cc - 94 HP - 69 kW
 Mot/Eng: 171C
 14700 = 82563 + 82598 (2)
 Type/Typ: XB serie XE/XET

96016570 9619139CAT	95634349 31392	95650909 61393 MK 85839	96048419 613697 MK 85047
------------------------	-------------------	-------------------------------	--------------------------------

7317160

BX
16-Image-Millésime-Evasion
 1.6i
07/86-12/94
 1580 cc - 89 HP - 65 kW
 Mot/Eng: XU5M (Single Point Inj.)
 Type/Typ: XB
 TSN: 488

96076275 31359	95588569 31361	95588570 61362 MK 85675	96046471 61363 MK 85029
-------------------	-------------------	-------------------------------	-------------------------------

7315445

BX
19GT-TRS-TGS-TZS-Digit
 1.9
07/85-12/92
 1905 cc - 105, 107 HP - 77, 79 kW
 Mot/Eng: D2A
 14700 = 82563 + 82598 (2)
 Type/Typ: XB serie XG/XF
 TSN: 421

Los nombres y números de primer equipo se utilizan solamente como referencia

● En desarrollo

IMPORTANTE:

Al pedir sistemas de escape, rogamos completen la referencia comenzando por 'MFO.' (ejemplo: 381394 → MFO.381394)

Pour commander echappement, nous vous prions de compléter la référence en commençant par MFO..

When ordering exhaust, please complete the reference by beginning with MFO..

ESCAPE / ECHAPPEMENT / EXHAUST

MOTOR / MOTEUR / ENGINE

Citroën

Fonor

BX
19TRS-Tri-GTi-TZi
 1.9
07/88-12/94
 1905 cc - 109, 120, 122 HP - 80, 88, 90 kW
 Mot/Eng: DKZ, DDZ
 Type/Typ: XB Serie XBA
 TSN: 470-476

96016570 96 19139 CAT	95634349 31392	95650909 61393 MK 85839	96048418 61394 MK 85047
---------------------------------	--------------------------	--------------------------------------	--------------------------------------

CI10065 **CAT** 7317160

BX
19TRS-Evasion
 1.9
07/85-12/92
 1905 cc - 105, 107 HP - 77, 79 kW
 Mot/Eng: D2A
 14700 = 82563 + 82598 (2)
 Type/Typ: XB serie XH/FT
 TSN: 435

96076275 31359	95588569 31361	95588570 61362 MK 85675	96046482 61346 MK 85029
--------------------------	--------------------------	--------------------------------------	--------------------------------------

CI61021 7315445

BX
19Tri-TZi-Evasion
 1.9i
07/88-12/92
 1905 cc - 125 HP - 92 kW
 Mot/Eng: D6A-XU9
 14700 = 82563 + 82598 (2)
 Type/Typ: XB serie XH/FTZ

95632640 61391	95634349 31392	95650909 61393 MK 85839	96048419 613697 MK 85047
--------------------------	--------------------------	--------------------------------------	---------------------------------------

CI61023 7312803

BX
19TRS-Tri-TGi-TZi
Evasion
 1.9, 1.9i
07/88-12/94
 1905 cc - 109, 123 HP - 80, 89 kW
 Mot/Eng: DKZ-DDZ-D6D-XU9J2
 (A) incl. 80 kW
 Type/Typ: XB Serie XBA

96016570 96 19139 CAT(A)	95634349 31392	95650909 61393 MK 85839	96048419 613697 MK 85047
------------------------------------	--------------------------	--------------------------------------	---------------------------------------

CI10066 **CAT** 7317160

BX
19 GTi
 1.9 GTi 16v
10/87-12/94
 1905 cc - 148 HP - 109 kW
 Mot/Eng: DFW-XU9J4 Multi point inj.
 TSN: 229-467

96016571 N.D. CAT	95634349 31392	95650909 61393 MK 85839	96068951 5217118
-----------------------------	--------------------------	--------------------------------------	----------------------------

CI61037 **CAT** 7317160

BX
19GTi-Sport
 1.9i
03/85-09/86
 1905 cc - 126 HP - 93 kW
 Mot/Eng: 159B (Single Point Inj.)
 14700 = 82563 + 82598 (2)
 Type/Typ: XB serie XJ

95632640 61391	95634349 31392	95650909 61393 MK 85839	96048418 61394 MK 85047
--------------------------	--------------------------	--------------------------------------	--------------------------------------

CI10031 7312803

● En desarrollo



Los nombres y números de primer equipo se utilizan solamente como referencia

IMPORTANTE:

Al pedir sistemas de escape, rogamos completen la referencia comenzando por 'MFO.' (ejemplo: 381394 → MFO.381394)

Pour commander echappement, nous vous prions de compléter la référence en commençant par MFO..

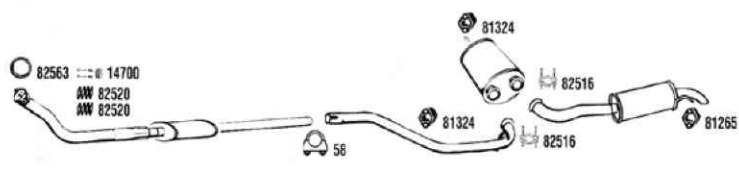
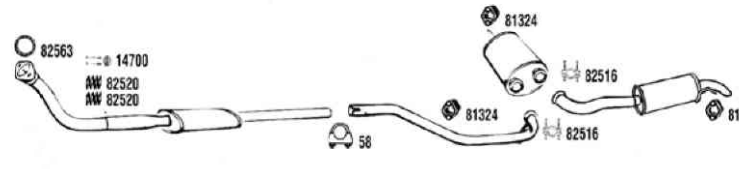
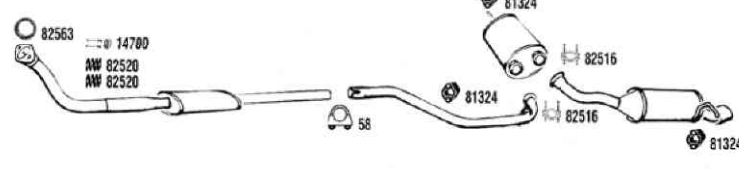
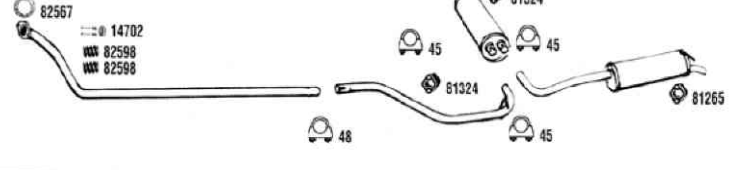
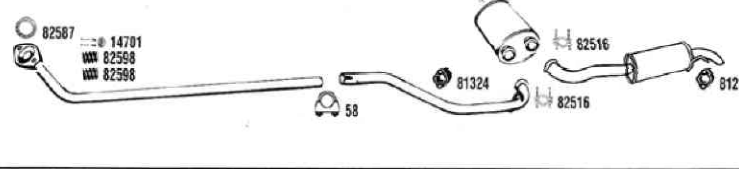
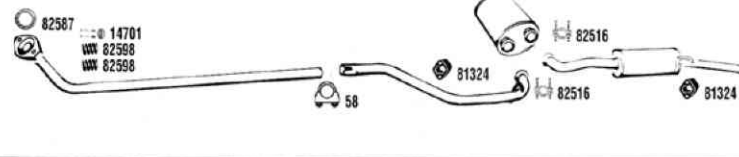
When ordering exhaust, please complete the reference by beginning with MFO..

<p>95632640 61391</p> <p>95634349 31392</p> <p>95650909 61393 MK 85839</p> <p>96048418 61394 MK 85047</p>  <p>82563 14700 AW 82520 AW 82520</p> <p>81324</p> <p>82516</p> <p>81265</p> <p>58</p> <p>7312803</p>	<p>BX 19GTi-Sport 1.9i 10/86-12/92 1905 cc - 125 HP - 93 kW Mot/Eng: D6A-XU9 14700 = 82563 + 82598 (2) Type/Typ: XB serie EG/FY TSN: 443</p> <p>Ci61022</p>
<p>96064537 6513699</p> <p>95634349 31392</p> <p>95650909 61393 MK 85839</p> <p>96048418 61394 MK 85047</p>  <p>82563 14700 AW 82520 AW 82520</p> <p>81324</p> <p>82516</p> <p>81265</p> <p>58</p> <p>7312803</p>	<p>BX 19 GTi 1.9 GTi 16v 01/87-12/92 1905 cc - 160 HP - 118 kW Mot/Eng: D6C ch.no. - EJ4495 14700 = 82563 + 82598 (2) Type/Typ: XB serie EJ TSN: 450</p> <p>Ci61024</p>
<p>96064537 6513699</p> <p>95634349 31392</p> <p>95650909 61393 MK 85839</p> <p>96068951 5217118</p>  <p>82563 14700 AW 82520 AW 82520</p> <p>81324</p> <p>82516</p> <p>81265</p> <p>58</p> <p>7312803</p>	<p>BX 19 GTi 1.9 GTi 16v 01/93-12/94 1905 cc - 160 HP - 118 kW Mot/Eng: D6C ch.no. EJ4496- 14700 = 82563 + 82598 (2) Type/Typ: XB serie EJ TSN: 450</p> <p>Ci61026</p>
<p>95590439 31370</p> <p>95588569 31361</p> <p>95588570 61362 MK 85675</p> <p>96046471 61363 MK 85029</p>  <p>82567 14702 AW 82598 AW 82598</p> <p>81324</p> <p>82516</p> <p>81265</p> <p>45</p> <p>48</p> <p>45</p> <p>7301205</p>	<p>BX 18D-RD-TRD-TGD 1.8 Diesel 10/83-12/94 1769 cc - 61 HP - 45 kW Mot/Eng: XUD7 14700 = 82563 + 82598 (2) Type/Typ: XB serie XP/XPT TSN: 432</p> <p>Ci61066</p>
<p>95039219 31366</p> <p>95634349 31392</p> <p>95650909 61393 MK 85839</p> <p>96048418 61394 MK 85047</p>  <p>82587 14701 AW 82598 AW 82598</p> <p>81324</p> <p>82516</p> <p>81265</p> <p>58</p> <p>7314908</p>	<p>BX 18RD-TRD-TZD-TXD 1.8 TD 03/88-04/94 1769 cc - 91 HP - 67 kW Mot/Eng: XUD7TE 14700 = 82563 + 82598 (2) Type/Typ: XB serie EK TSN: 465</p> <p>Ci61033</p>
<p>95039219 31366</p> <p>95634349 31392</p> <p>95650909 61393 MK 85839</p> <p>96048419 613697 MK 85047</p>  <p>82587 14701 AW 82598 AW 82598</p> <p>81324</p> <p>82516</p> <p>81265</p> <p>58</p> <p>7314908</p>	<p>BX 18D-RD-TRD-TGD-TZD- Evasion  1.8 TD 03/88-04/93 1769 cc - 91 HP - 67 kW Mot/Eng: XUD7TE Type/Typ: XB serie EL TSN: 466</p> <p>Ci61034</p>

Los nombres y números de primer equipo se utilizan solamente como referencia

● En desarrollo

IMPORTANTE:

Al pedir sistemas de escape, rogamos completen la referencia comenzando por 'MFO.' (ejemplo: 381394 → MFO.381394)

Pour commander echappement, nous vous prions de compléter la référence en commençant par MFO..

When ordering exhaust, please complete the reference by beginning with MFO..

ESCAPE / ECHAPPEMENT / EXHAUST

Citroën

BX
19D-RD-TRD-TGD
 1.9 Diesel
10/83-12/94
 1905 cc - 65, 70 HP - 48, 51 kW
 Mot/Eng: XUD9, XUD9A
 Type/Typ: XB serie XC/XCT
 TSN: 412-458

95590439 95588569 95588570 96046471
31370 31361 61362 61363
 MK 85675 MK 85029

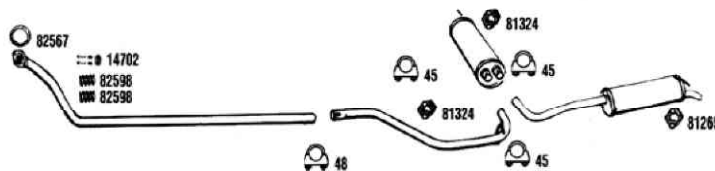

 **7301205**

C161031
BX
19D-RD-TRD-TGD-TZD-
Evasion 
 1.9 Diesel
07/85-12/94
 1905 cc - 65, 70 HP - 48, 51 kW
 Mot/Eng: XUD9-XUD9A
 Type/Typ: XB serie XF
 TSN: 433, 459

95590439 95588569 95588570 96046482
31370 31361 61362 61346
 MK 85675 MK 85029

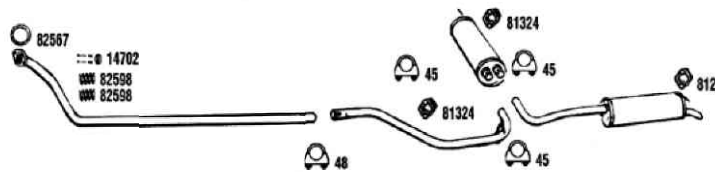

 **7301205**

C161041
CX 
 2.0, 2.2
08/74-07/78
 1985, 2165 cc - 102, 112 HP - 75, 82 kW
 Type/Typ: MA serie MB/MC/MD/MH
 TSN: 368-369-372

5634129 75492604 75492528 95610049 95543645
1340 1341-F 613263 6601164 631339
 MK 85192

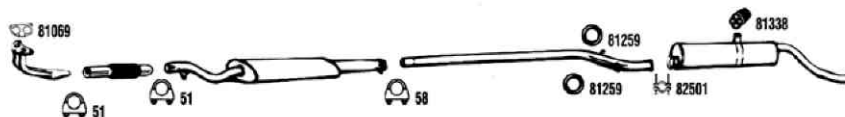

 **7301205**

C170001
CX
Super-Pallas-Confort 
 2.0
08/78-07/79
 1985 cc - 102 HP - 75 kW
 Type/Typ: MA serie MB/MD
 TSN: 368-372

5634129 75491874 54907474 95610049 95543645
1340 N.D. N.D. 6601164 631339
 MK 85192

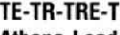

C170002
CX
TE-TR-TRE-TRS 
Athena-Leader-Pallas-Reflex
 2.0, 2.2
08/79-05/89
 1985, 2165 cc - 106, 113 HP - 78, 83 kW
 Mot/Eng: J6TA50
 Type/Typ: MA serie MP/MR/NR/NS
 TSN: 385-389

95610748 95549728 95610049 95543645
N.D. 613261 6601164 631339
 MK 85192



C170003
CX
Athena-Pallas-Reflex 
 2.0, 2.2
07/80-05/89
 1985, 2165 cc - 106, 115 HP - 78, 85 kW
 Type/Typ: MA serie MP/MR
 TSN: 385-389

95610748 95549728 95610049 95543645
N.D. 613261 6601164 631339
 MK 85192















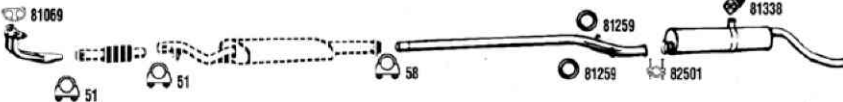

C170004
 ● En desarrollo

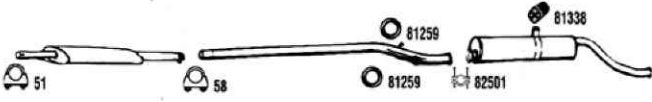
Los nombres y números de primer equipo se utilizan solamente como referencia

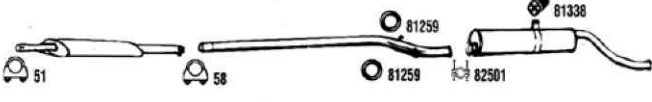
IMPORTANTE:

Al pedir sistemas de escape, rogamos completen la referencia comenzando por 'MFO.' (ejemplo: 381394 → MFO.381394)
 Pour commander echappement, nous vous prions de compléter la référence en commençant par MFO..
 When ordering exhaust, please complete the reference by beginning with MFO..

95610748 N.D.	95549728 613261	95610049 6601164	95543645 631339 MK 85192	<p>CX 22-TRS  2.2 11/85-12/89 2165 cc - 115 HP - 85 kW Mot/Eng: J6 TA50 Type/Typ: MA serie NS</p> <p>CI70008</p>	
					
5634129 1340	75492604 1341-F	75492528 613263	95610049 6601164	95543645 631339 MK 85192	<p>CX Super-GTi-Pallas-C. Matic-Prestige   2.4, 2.4i 01/76-06/80 2347 cc - 115, 128 HP - 85, 94 kW Type/Typ: MA serie ME/MF/MJ/MK/ML TSN: 374-375-399-401</p> <p>CI70011</p>
					
5634129 1340	75491874 N.D.	54907474 N.D.	95610049 6601164	95543645 631339 MK 85192	<p>CX Pallas-GTi-Super-C. Matic-Prestige   2.4, 2.4i 08/78-11/78 2347 cc - 115, 128 HP - 85, 94 kW Type/Typ: MA serie ME/MF/MJ/MK/ML TSN: 374-375-399-401</p> <p>CI70012</p>
					
95549728 613261	95610049 6601164	95543645 631339 MK 85192	<p>CX Ri-Pallas-GTi-C. Matic-Prestige   2.4i 07/80-06/85 2347 cc - 128 HP - 94 kW Type/Typ: MA serie MT/MV/MW/MY/MZ/NA/NE TSN: 374-377-400</p> <p>CI70014</p>		
					
95549728 613261	95610049 6601164	95543645 631339 MK 85192	<p>CX GTi-Tri   2.5i 07/83-06/85 2499 cc - 138 HP - 101 kW ch.no. -PR2884 Type/Typ: MA serie NG/NH/NJ TSN: 414-417</p> <p>CI70015</p>		
					
5634129 1340	75492604 1341-F	75492528 613263	95610049 6601164	95543645 631339 MK 85192	<p>CX GTi-Tri-Pallas IE   2.5i 07/85-12/90 2499 cc - 138 HP - 101 kW Mot/Eng: M25//659 ch.no. PR2885- Type/Typ: MA serie NG/NH/NJ TSN: 414-417</p> <p>CI70016</p>
					

Los nombres y números de primer equipo se utilizan solamente como referencia

● En desarrollo

IMPORTANTE:

Al pedir sistemas de escape, rogamos completen la referencia comenzando por 'MFO.' (ejemplo: 381394 → MFO.381394)

Pour commander echappement, nous vous prions de compléter la référence en commençant par MFO..

When ordering exhaust, please complete the reference by beginning with MFO..

ESCAPE / ECHAPPEMENT / EXHAUST

Fonos

MOTOR / MOTEUR / ENGINE

Citroën

CX

GTi-TRi-Pallas IE



2.5i Autom.

07/85-12/90

2499 cc - 138 HP - 101 kW

Mot/Eng: M25-659

ch.no. PR2885-

Type/Typ: MA serie NG

TSN: 414-417

CI50166

95636181 N.D.	75492604 1341-F	75492528 613263	95610049 6601164	95543645 631339 MK 85192
-------------------------	---------------------------	---------------------------	----------------------------	---------------------------------------

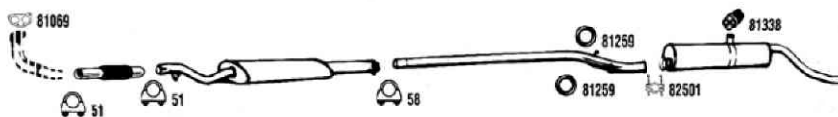

CX

TRi-GTi-Prestige



2.5i

08/86-12/91

2499 cc - 122 HP - 89 kW

TSN: 447-450

CI50169

CAT

95633945 N.D.	95636322 N.D.	95633537 N.D.CAT	95610049 6601164	95543645 631339 MK 85192
-------------------------	-------------------------	----------------------------	----------------------------	---------------------------------------

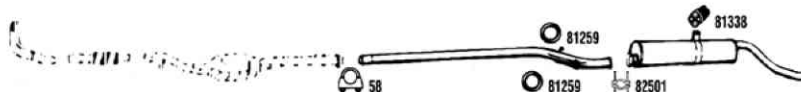

CX

Turbo 2 Prestige



2.5i

08/86-12/90

2499 cc - 168 HP - 124 kW

Mot/Eng: M25-662

Type/Typ: MA serie NP

TSN: 422

CI50163

λ ¹	87854	87910	87999
----------------	-------	-------	-------

95604310 N.D.	95604312 N.D.	95605238 N.D.	95633748 6712273¹
-------------------------	-------------------------	-------------------------	--

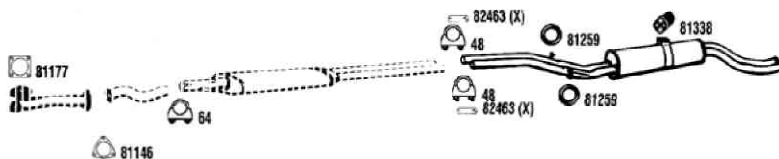

7312804

CX

Confort-Super

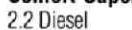

2.2 Diesel

07/75-06/80

2175 cc - 66 HP - 49 kW

Type/Typ: MA serie MG-MA serie MH

TSN: 371-373

CI70031

5634129 1340	75492604 1341-F	75492528 613263	95610049 6601164	95543645 631339 MK 85192
------------------------	---------------------------	---------------------------	----------------------------	---------------------------------------

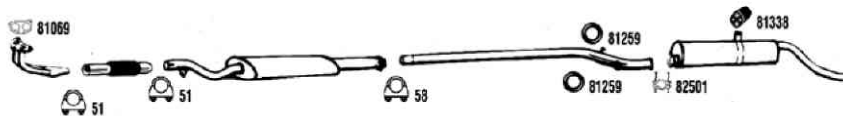

CX

Confort-Pallas-Super-Limousine



2.5 Diesel

01/78-06/80

2499 cc - 75 HP - 55 kW

Type/Typ: MA serie MM/MN/MS

TSN: 380-381-388-391-418

CI70032

5634129 1340	75492604 1341-F	75492528 613263	95610049 6601164	95543645 631339 MK 85192
------------------------	---------------------------	---------------------------	----------------------------	---------------------------------------

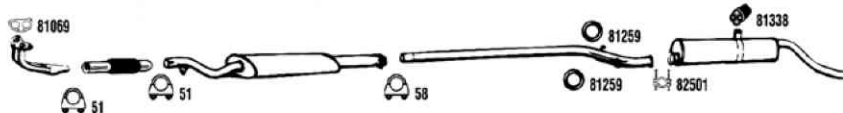

CX

Confort-Pallas

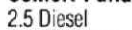

2.5 Diesel

07/80-12/81

2499 cc - 75 HP - 55 kW

Type/Typ: MA serie MM/MN/MS

TSN: 380-381-388-391-418

CI70034

95549728 613261	95610049 6601164	95543645 631339 MK 85192
---------------------------	----------------------------	---------------------------------------



● En desarrollo

Los nombres y números de primer equipo se utilizan solamente como referencia

IMPORTANTE:

Al pedir sistemas de escape, rogamos completen la referencia comenzando por 'MFO.' (ejemplo: 381394 → MFO.381394)

Pour commander echappement, nous vous prions de compléter la référence en commençant par MFO..

When ordering exhaust, please complete the reference by beginning with MFO..



Fonos

Citroën



5634129 1340	75492604 1341-F	75492528 613263	95610049 6601164	95543645 631339 MK 85192
------------------------	---------------------------	---------------------------	----------------------------	---------------------------------------

CX
Confort-Pallas 
 2.5 Diesel
08/80-12/90
 2499 cc - 75 HP - 55 kW
 Type/Typ: MA serie MM/MN/MS
 TSN: 381-391-418

95571212 N.D.	95571790 N.D.	N.D.	95596746 6601211	95572142 5301200(A)
-------------------------	-------------------------	-------------	----------------------------	-------------------------------

CX
RD-TRD 
 2.5 TD
04/83-09/85
 2499 cc - 95 HP - 70 kW
 ch.no. -PR3218
 (A) 
 Type/Typ: MA serie NB/NC/ND-
 Type/Typ: MA serie ND
 TSN: 409-416

95596750 N.D.	95598991 6112275	95596746 6412276	95596746 6601211	95572142 5301200(A)
-------------------------	----------------------------	----------------------------	----------------------------	-------------------------------

CX
RD-TRD 
 2.5 TD
10/85-02/87
 2499 cc - 95 HP - 70 kW
 Mot/Eng: M25-648
 ch.no. PR3219-
 (A) 
 Type/Typ: MA serie NB/NC/ND
 TSN: 409-416

95598991 6112275	95596746 6412276	95596746 6601211	95572142 5301200
----------------------------	----------------------------	----------------------------	----------------------------

CX 2
RD-TRD 
 2.5 TD
03/87-12/90
 2499 cc - 120 HP - 88 kW
 Mot/Eng: M25/648
 ch.no. PR3766-
 Type/Typ: MA serie NT-MA serie NU
 TSN: 455-457

1731 V8 9220573CAT	1717V7 6607641	1726 NT 613306
------------------------------	--------------------------	--------------------------

C 2
Hatchback
 1.1
09/03-
 1124 cc - 60 HP - 44 kW
 Mot/Eng: TU1JP/L4
 Type/Typ: JMHFXB

1731 W0 9220574CAT	1717V8 613634	1726 NV 613308
------------------------------	-------------------------	--------------------------

C 2
Hatchback
 1.4
09/03-
 1360 cc - 75 HP - 55 kW
 Mot/Eng: TU3JP/L4
 Type/Typ: JMKFVB

Los nombres y números de primer equipo se utilizan solamente como referencia ● En desarrollo

IMPORTANTE:

Al pedir sistemas de escape, rogamos completen la referencia comenzando por 'MFO.' (ejemplo: 381394 → MFO.381394)
 Pour commander echappement, nous vous prions de compléter la référence en commençant par MFO..
 When ordering exhaust, please complete the reference by beginning with MFO..

ESCAPE / ECHAPPEMENT / EXHAUST

Fonos

MOTOR / MOTEUR / ENGINE

Citroën

C 2
Hatchback
 1.6 16v
09/03-
 1587 cc - 110 HP - 81 kW
 Mot/Eng: TU5JP4/L4
 Type/Typ: JMNFB/P

CI20010 **CAT**

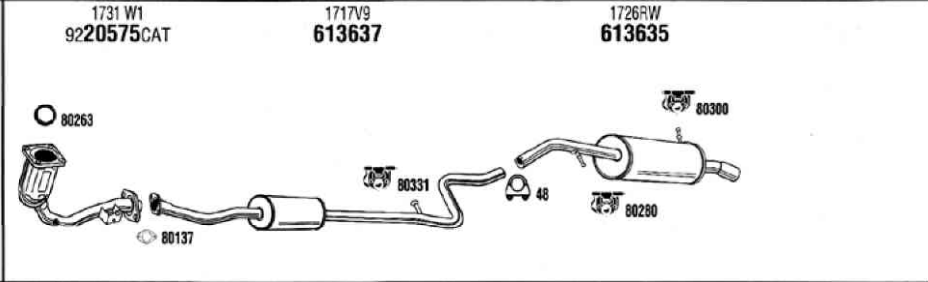

C 2
Hatchback -
 1.4 HDi 8v
09/03-
 1398 cc - 69 HP - 51 kW
 Mot/Eng: DV4TD/L4
 Type/Typ: JG8H_JM8H

CI20013 **CAT**

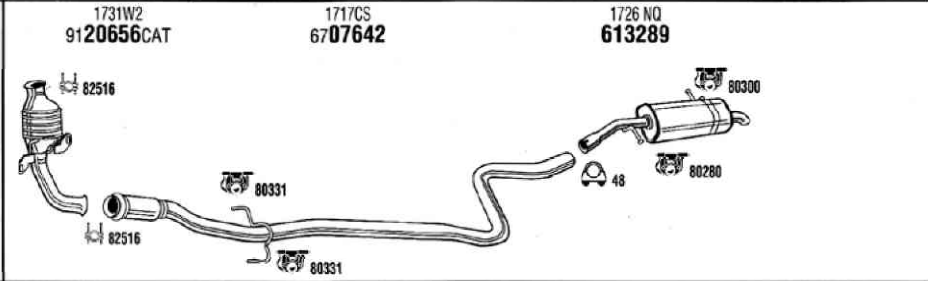

C 3
Hatchback -
 1.1
02/02-
 1124 cc - 60 HP - 44 kW
 Mot/Eng: TU1JP

 Type/Typ: FCHFX***-FNHFX***-FRHFX***

CI30010 **CAT**

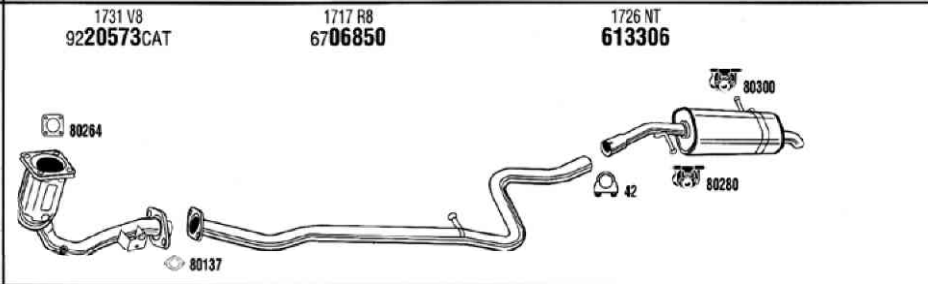

C 3
Hatchback
 1.4
02/02-
 1360 cc - 75 HP - 55 kW
 Mot/Eng: TU3JP

 Type/Typ: FCKFV***-FNKRV***

CI30011 **CAT**

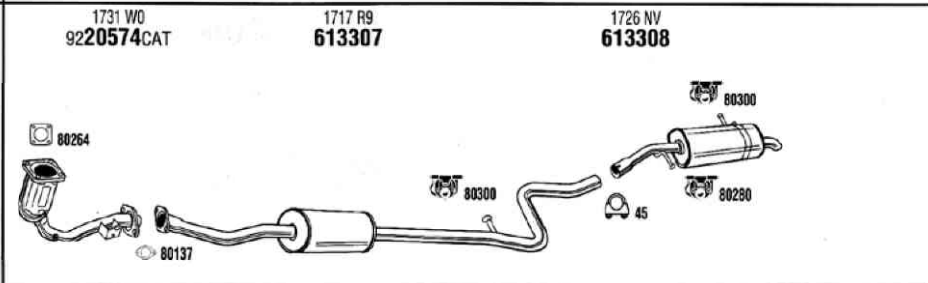

C 3
Hatchback
 1.6
02/02-
 1597 cc - 110 HP - 81 kW
 Mot/Eng: TU5JP4

 Type/Typ: FCNFU***-FNNFU***

CI30014 **CAT**

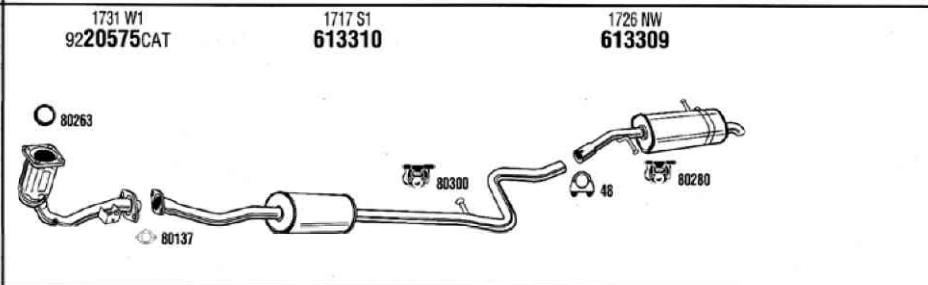

C 3
Hatchback -
 1.4 HDi 8v
02/02-
 1398 cc - 69 HP - 51 kW
 Mot/Eng: DV4TD

 Type/Typ: FC8HX**-FN8HX**-FR8HX**

CI30012 **CAT**

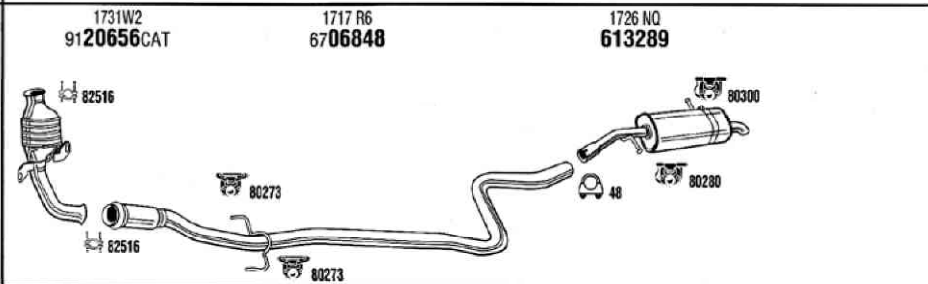

● En desarrollo

Los nombres y números de primer equipo se utilizan solamente como referencia

IMPORTANTE:

Al pedir sistemas de escape, rogamos completen la referencia comenzando por 'MFO.' (ejemplo: 381394 → MFO.381394)

Pour commander echappement, nous vous prions de compléter la référence en commençant par MFO..

When ordering exhaust, please complete the reference by beginning with MFO..

Fonos

Citroën

1731W2 9120656CAT	1717 R7 6706849	1726 NR 613304
----------------------	--------------------	-------------------

C 3
Hatchback -
1.4 HDi 16v
02/02-
1398 cc - 92 HP - 68 kW
Mot/Eng: DV4TED4
Type/Typ: FC8HY** - FN8HY**
CI30013 CAT

1705ZH N.D.CAT	1717W6 N.D.	1717W7 615802	1726VZ 615804
-------------------	----------------	------------------	------------------

C 4
Hatchback, Coupé
1.4 16v
11/04-
1360 cc - 88 HP - 65 kW
Mot/Eng: KFJ (ET3J4)
CIW40010 CAT

1731EL N.D.CAT(B)	1717AK 615212	1726TZ 615213 MK 85898
----------------------	------------------	------------------------------

C 4
Hatchback, Coupé
1.6 16v
11/04-
1587 cc - 109 HP - 80 kW
Mot/Eng: NFU (TU5JP4)
Transmission Type:(A) Autom.
Transmission Type:(B) Autom.
CIW40011 CAT

1731GB N.D.CAT	1717 P6 615215	1726VA 615210 MK 85899
-------------------	-------------------	------------------------------

C 4
Hatchback, Coupé
2.0 16v
11/04-
1997 cc - 136 HP - 100 kW
Mot/Eng: RFN (EW10J4)
CIW40012 CAT

17068B N.D.CAT	1705ZR 6107967	1717Z9 6708227	1726WS 615211 MK 85899
-------------------	-------------------	-------------------	------------------------------

C 4
Hatchback, Coupé
1.6 HDi
11/04-
1560 cc - 90 HP - 66 kW
Mot/Eng: DV6ATED4/9HX
CIW40013 CAT

1705ZS 9120693CAT(A)	1705ZR 6107967	1717Z9 6708227	1726WS 615211 MK 85899
-------------------------	-------------------	-------------------	------------------------------

C 4
Hatchback, Coupé
1.6 HDi
11/04-
1560 cc - 109 HP - 80 kW
Mot/Eng: DV6TED4
Mot/Eng: (A) DV6TED4/9HY - Mot/Eng: (B) DV6TED4/9HZ
Emission:(A) Euro 2000
Emission:(B) Euro 2005
CIW40014 CAT

Los nombres y números de primer equipo se utilizan solamente como referencia

● En desarrollo

IMPORTANTE:

Al pedir sistemas de escape, rogamos completen la referencia comenzando por 'MFO.' (ejemplo: 381394 → MFO.381394)
Pour commander echappement, nous vous prions de compléter la référence en commençant par MFO..
When ordering exhaust, please complete the reference by beginning with MFO..

ESCAPE / ECHAPPEMENT / EXHAUST

Fonos

Citroën

C 4
Hatchback, Coupé
 2.0 HDi
11/04-
 1997 cc - 136 HP - 100 kW
 Mot/Eng: DW10BTE4/RHR
 W/ Particle Filter

1731GF
 N.D.CAT

1717V2
 6508214

1726WS
 615211
 MK 85899

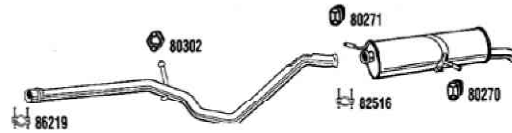

CIW40015 **CAT**

C 5
Hatchback 
 1.8
10/00-08/02
 1749 cc - 117 HP - 86 kW
 Mot/Eng: EW7J4
 Type/Typ: DC,DE

1705HY
 N.D.CAT

1726 HL
 613185
 MK 85862



CI51012 **CAT**

C 5
Hatchback 
 1.8
08/02-
 1749 cc - 117 HP - 86 kW
 Mot/Eng: EW7J4
 Type/Typ: DC,DE

1705QZ
 ● 9720640CAT

1726RT
 613716

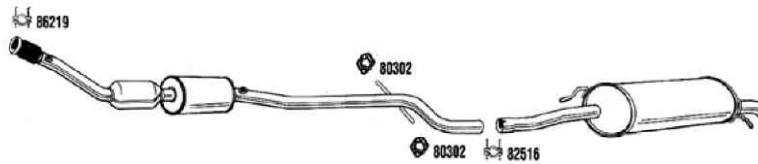

CI51013 **CAT**

C 5
Hatchback 
 2.0
10/00-08/02
 1997 cc - 136 HP - 100 kW
 Mot/Eng: EW10J4
 (A)= DEPOL. L4 / IFL5 / US83
 (B)= DEPOL. K PRIM
 Type/Typ: DCRFNC-DCRFNF-DERFNC-DERFNF

1705HY
 N.D.CAT(A)

1726 HL
 613185
 MK 85862



CI51007 **CAT**

C 5
Hatchback 
 2.0
08/02-
 1997 cc - 136 HP - 100 kW
 Mot/Eng: EW10J4
 (A)= Excl.DEPOL. K PRIM
 Type/Typ: DCRFNC-DCRFNF-DERFNC-DERFNF

N.D.CAT(B)
 1705 KL

1726RT
 613716

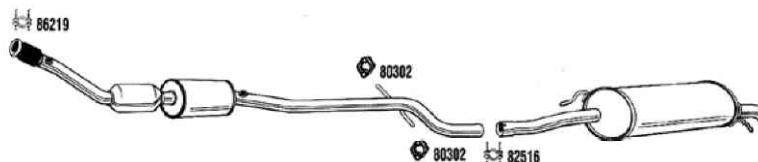

CI51014 **CAT**

C 5
Hatchback 
 2.0 HPi
10/00-
 1997 cc - 140 HP - 103 kW
 Mot/Eng: EW10D
 (A) = -08/02 (B)= 08/02-
 Type/Typ: DCR LZB- DER LZB

1705 HZ
 N.D.CAT

1705 HX
 N.D.CAT

1726 HL
 613185(A)
 MK 85862

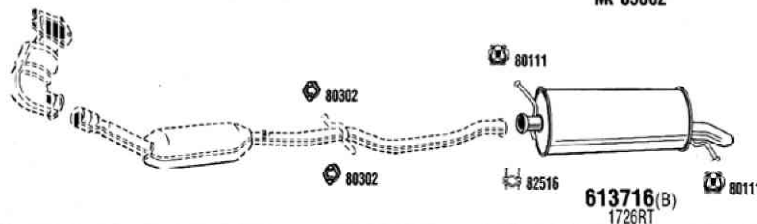

CI51008 **CAT**

● En desarrollo

Los nombres y números de primer equipo se utilizan solamente como referencia

IMPORTANTE:

Al pedir sistemas de escape, rogamos completen la referencia comenzando por 'MFO.' (ejemplo: 381394 → MFO.381394)

Pour commander echappement, nous vous prions de compléter la référence en commençant par MFO..

When ordering exhaust, please complete the reference by beginning with MFO..

1705KG N.D.CAT	1705KE N.D.	1705RF N.D.CAT	1726RP 613768(A)
-------------------	----------------	-------------------	---------------------

C 5
Hatchback ,
3.0 V6 24v
02/01-
2946 cc - 210 HP - 155 kW
Mot/Eng: ES9J4S
(A) 08/02 - (B) -08/02
Type/Typ: DCX,DEX

Ci51011 **CAT**

1705HW N.D.CAT	N.D.(B) 1726HK 613184 MK 85868
-------------------	---

C 5
Hatchback ,
2.0 HDi
10/00-08/02
1997 cc - 90 HP - 66 kW
Mot/Eng: DW10TD
Type/Typ: DCRHYB-DERHYB

Ci51010 **CAT**

1705RG 9720644CAT	1726RV 613699
----------------------	------------------

C 5
Hatchback ,
2.0 HDi
08/02-
1997 cc - 90 HP - 66 kW
Mot/Eng: DW10TD
Type/Typ: DCRHYB-DERHYB

Ci51015 **CAT**

1706HW N.D.CAT	1726 HH 613184 MK 85868
-------------------	-------------------------------

C 5
Hatchback ,
2.0 HDi
10/00-08/02
1997 cc - 109 HP - 80 kW
Mot/Eng: DW10ATED
DERHZE - DERHZE = 03/01-
Type/Typ: DCRHZE-DCRHZE = Hatchback
Type/Typ: DERHZE-DEHZE = Wagon

Ci51001 **CAT**

1705RG 9720644CAT	1726RV 613699
----------------------	------------------

C 5
Hatchback ,
2.0 HDi
08/02-
1997 cc - 109 HP - 80 kW
Mot/Eng: DW10ATED
Type/Typ: DCRHZE-DCRHZE = Hatchback
Type/Typ: DERHZE-DEHZE = Wagon

Ci51016 **CAT**

1705 HV 6106549	1731 L5 N.D.CAT	1731 L6 N.D.CAT	1717 K1 6506498	1726 HJ 613183
--------------------	--------------------	--------------------	--------------------	-------------------

C 5
Hatchback ,
2.2 HDi
10/00-
2179 cc - 133 HP - 98 kW
Mot/Eng: DW12TED4
DE4HXB - DE4HXE = 03/01-
Type/Typ: DC4HXB-DC4HXE = Hatchback
Type/Typ: DE4HXB-DE4HXE = Wagon

Ci51002 **CAT**

Los nombres y números de primer equipo se utilizan solamente como referencia

● En desarrollo

IMPORTANTE:

Al pedir sistemas de escape, rogamos completen la referencia comenzando por 'MFO.' (ejemplo: 381394 → MFO.381394)
 Pour commander echappement, nous vous prions de compléter la référence en commençant par MFO..
 When ordering exhaust, please complete the reference by beginning with MFO..

ESCAPE / ECHAPPEMENT / EXHAUST

MOTOR / MOTEUR / ENGINE

Citroën

Fonos

C 8
MPV
 2.0 HDi
06/02-
 1997 cc - 109 HP - 80 kW
 Mot/Eng: RHW (DW10ATED4)
 Type/Typ: E
W/O Particle Filter

CIW80002 **CAT**

1705 NW 1717R1 1726LV
 9220615CAT N.D. N.D.

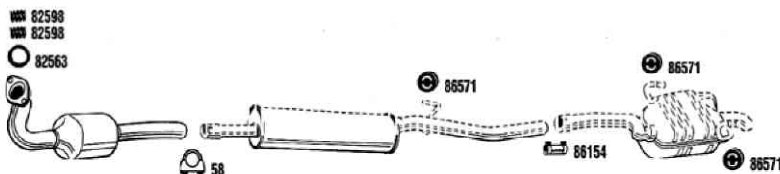

C 8
MPV
 2.0 HDi
06/02-
 1997 cc - 109 HP - 80 kW
 Mot/Eng: RHM (DW10ATED4)
 Mot/Eng: RHT (DW10ATED4)
 Type/Typ: E
W/ Particle Filter

CIW80001 **CAT**

1731X7 1731X9 1717R2 1726LX
 N.D.CAT N.D.CAT 6408228 ●610675

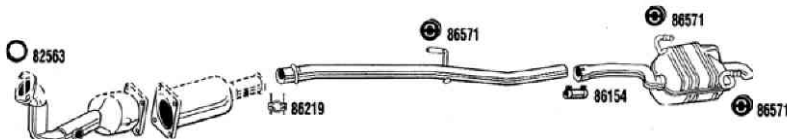

C 8
MPV
 2.2 HDi
07/02-
 2179 cc - 128 HP - 94 kW
 Mot/Eng: 4HX (DW12TED4)
 Mot/Eng: 4HW (DW12TED4)
W/ Particle Filter

CIW80003 **CAT**

1731X8 1731X9 1717R2 1726LZ
 N.D.CAT N.D.CAT 6408228 ●610849

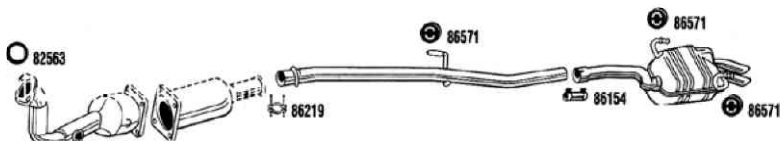

C 15

 1.0, 1.1
07/84-06/88
 954, 1124 cc - 45, 50 HP - 33, 37 kW
 ch.no. -PR4195
 Type/Typ: VD serie PA
 TSN: 440-507

CI50010

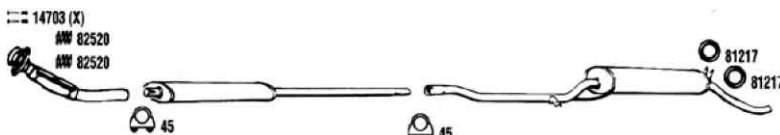
9150246180 95602665 95602667
31348 61382 61383



7312799

C 15

 1.1, 1.3
07/87-06/88
 1118, 1294 cc - 55, 65 HP - 40, 48 kW
 Mot/Eng: E1A, G1A
 ch.no. -PR4195
 Type/Typ: VD serie PS/PW

CI50011

96018812 96018813
N.D. 613200
 MK 85009



7314034

C 15

 1.0, 1.1
07/88-92
 954, 1124 cc - 45, 48 HP - 33, 35 kW
 Mot/Eng: 108C, 109K
 ch.no. PR4196-
 Type/Typ: VD Serie PL/SD/PA/PX
 TSN: 440-507

CI50018

96065832 96012771 96012772
6215427 31397 61398
 MK 85009



7315430

● En desarrollo

Los nombres y números de primer equipo se utilizan solamente como referencia

IMPORTANTE:

Al pedir sistemas de escape, rogamos completen la referencia comenzando por 'MFO.' (ejemplo: 381394 → MFO.381394)
 Pour commander echappement, nous vous prions de compléter la référence en commençant par MFO..
 When ordering exhaust, please complete the reference by beginning with MFO..

96033826 N.D.	96033827 N.D.CAT	96012772 61398 MK 85009
------------------	---------------------	--------------------------------------

7317532

C 15
1.1
10/89-95
1124 cc - 60 HP - 44 kW
Mot/Eng: TU1M (Single Point Inj.)
TSN: 206, 522

CI50021 **CAT**

95635129 6214035	95600364 61385	96001963 61386 MK 85071
---------------------	--------------------------	--------------------------------------

7314037

C 15
1.4
07/86-06/88
1360 cc - 60 HP - 44 kW
Mot/Eng: 150D
Type/Typ: VD serie PJ
TSN: 454-508

CI50014

N.D.CAT	95600364 61385	96001963 61386 MK 85071
---------	--------------------------	--------------------------------------

7315430

C 15
1.4 (Visa)
07/86-92
1360 cc - 55 HP - 40 kW

CI50016 **CAT**

96065832 6215427	96012771 31397	96012772 61398 MK 85009
---------------------	--------------------------	--------------------------------------

7315430

C 15
1.4
07/88-92
1360 cc - 66 HP - 49 kW
Mot/Eng: TU3
ch.no. PR4196-
Type/Typ: VD serie PJ/PK
TSN: 474-509

CI50017

1721 28 613509	95600360 31384	95600364 61385	96001963 61386 MK 85071
--------------------------	--------------------------	--------------------------	--------------------------------------

7312800

C 15
1.8 Diesel
07/84-01
1769 cc - 60 HP - 44 kW
Mot/Eng: XUD7
Type/Typ: VD serie PB/PP
TSN: 439-506

CI30307

1721 28 613509	1705 Y0 9620401CAT	96001963 61386 MK 85071
--------------------------	-----------------------	--------------------------------------

7312800

C 15
1.8 Diesel
95-01
1769 cc - 60 HP - 44 kW
Mot/Eng: XUD7
Type/Typ: PB-PP-VD

CI50031 **CAT**

Los nombres y números de primer equipo se utilizan solamente como referencia

● En desarrollo

IMPORTANTE:

Al pedir sistemas de escape, rogamos completen la referencia comenzando por 'MFO.' (ejemplo: 381394 → MFO.381394)
 Pour commander echappement, nous vous prions de compléter la référence en commençant par MFO..
 When ordering exhaust, please complete the reference by beginning with MFO..

ESCAPE / ECHAPPEMENT / EXHAUST

Citroën

Fonos

C 15

1.9 Diesel
03/01-
 1868 cc - 60 HP - 44 kW
 Mot/Eng: DW88
 (A) -09/01 - (B) 09/01-
 Type/Typ: VD

1705PQ **N.D.(B)** 1731V3 **9320654CAT(B)** 96001963 **61386**
 MK 85071



CI50032 CAT

C 25

1.8, 2.0
11/81-06/94
 1796, 1971 cc - 66, 78 HP - 49, 57 kW
 Mot/Eng: 170B
 Type/Typ: 1100-1300-290C2D
 TSN: 424-503

N.D.(A) 1705KN **N.D.CAT(A)** 1731PD

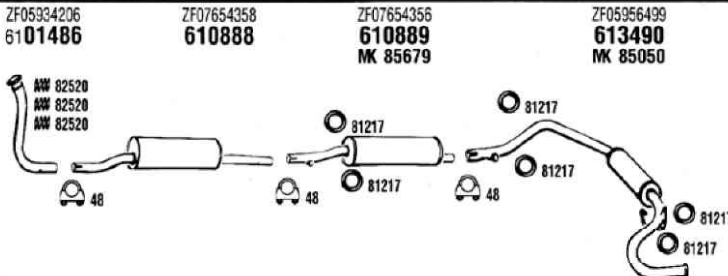

7301518

CI80001

C 25

1.9 Diesel
01/88-94
 1905 cc - 70 HP - 51 kW
 Mot/Eng: D9B
 Type/Typ: 290C50
 TSN: 200-423

95636428 **6114220** ZF07654358 **610888** ZF07654356 **610889** MK 85679 ZF07654355 **6501492** MK 85050

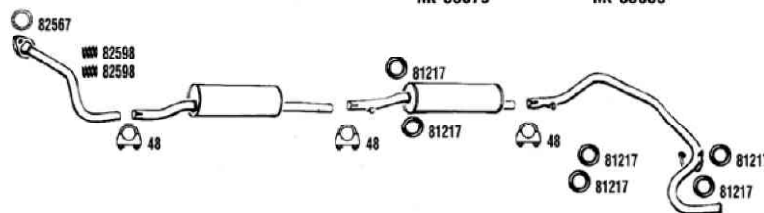

7317127

CI80005

C 25

Bus-Chassis cab
 2.0 Diesel
01/88-09/94
 1905 cc - 65 HP - 48 kW
 Mot/Eng: XUD9A
 ch.no. J0422601-
 Type/Typ: 280 Serie B62/C62
 TSN: 200-423

95636428 **6114220** ZF07654358 **610888** ZF07654356 **610889** MK 85679 ZF07654355 **6501492** MK 85050

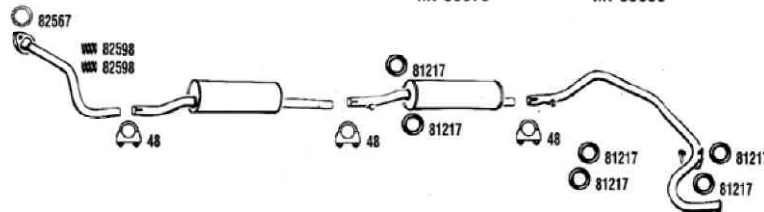

7317127

CI80002

C 25

R-RD Bus-Chassis cab
 2.5 Diesel
01/81-95
 2498 cc - 72, 74 HP - 53, 54 kW
 Mot/Eng: U2S661-crd
 Type/Typ: 290C50
 TSN: 202-204-425-426

ZF05925058 **6201487** ZF07654358 **610888** ZF07654356 **610889** MK 85679 ZF07654355 **6501492** MK 85050

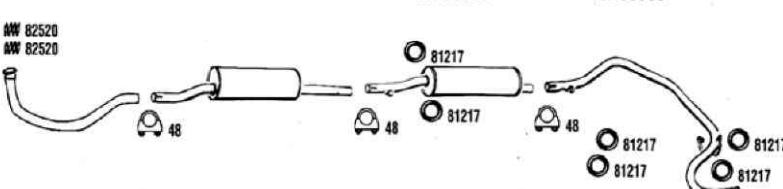

7301518

CI80012

C 25

2.5 TD
09/87-10/90
 2500 cc - 95 HP - 70 kW
 Mot/Eng: U2S673
 Type/Typ: 290G94-290J90
 (A)= with engine brake
 TSN: 203-205-513

96636914 **N.D.(A)** 95604311 **N.D.** 95640716 **6114224** ZF07710074 **613225** ZF07579139 **613226** MK 85678

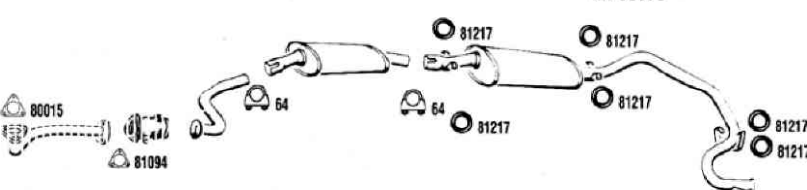

7314227

CI80016

● En desarrollo

Los nombres y números de primer equipo se utilizan solamente como referencia

IMPORTANTE:

Al pedir sistemas de escape, rogamos completen la referencia comenzando por 'MFO.' (ejemplo: 381394 → MFO.381394)
 Pour commander echappement, nous vous prions de compléter la référence en commençant par MFO..
 When ordering exhaust, please complete the reference by beginning with MFO..

ESCAPE / ECHAPPEMENT / EXHAUST

Fonos

MOTOR / MOTEUR / ENGINE

Citroën

Evasion / Synergie

MPV

2.0

06/94-07/02

1998 cc - 121 HP - 89 kW

Mot/Eng: RFU (XU10J2/C)

Type/Typ: 22, U6

CIT04051

CAT

1705 W2
9221581CAT
MK 21826

1717 55
613193
MK 85508

1726 E6
613192
MK 85509

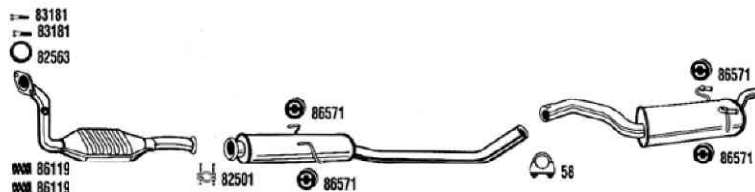

Evasion / Synergie

MPV

2.0 Turbo C.T.

06/94-07/02

1998 cc - 147 HP - 108 kW

Mot/Eng: RGX (XU10J2E)

Type/Typ: 22, U6

CIT04050

CAT

1705 H5
9221582CAT

171733
613190
MK 85571

1726 92
613191
MK 85509

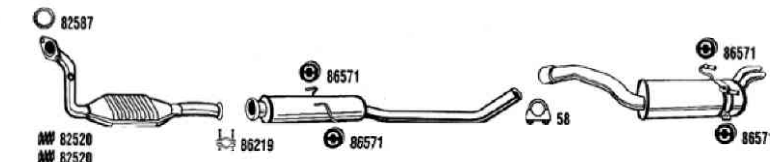

Evasion / Synergie

MPV

2.0 16v

05/98-04/00

1998 cc - 132 HP - 97 kW

Mot/Eng: RFV (XU10J4R)

Type/Typ: 22, U6

CIT11370A

CAT

1705 AL
9320508CAT

171705
610609
MK 85571

1726 Z7
610607
MK 85509

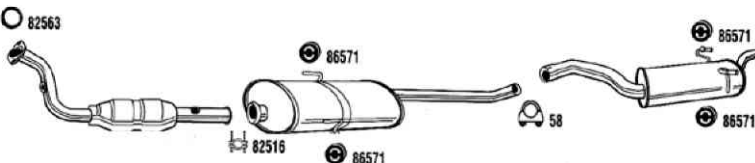

Evasion / Synergie

MPV

2.0 16v

05/00-07/02

1997 cc - 136 HP - 100 kW

Mot/Eng: RFN (EW10J4)

Type/Typ: 22, U6

CIT15085

CAT

1705 JR
9320593CAT

1717 L0
613288
MK 85880

1726 HW
610579
MK 85509

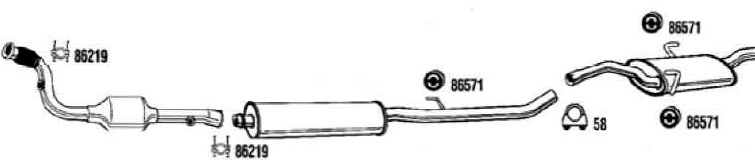

Evasion / Synergie

MPV

1.9 TD

11/94-07/02

1905 cc - 90 HP - 66 kW

Mot/Eng: D8B (XUD9TF)

Type/Typ: 22, U6

CIT04746A

CAT

1705 E1
6221583

1717 55
613193
MK 85508

1726 92
613191
MK 85509

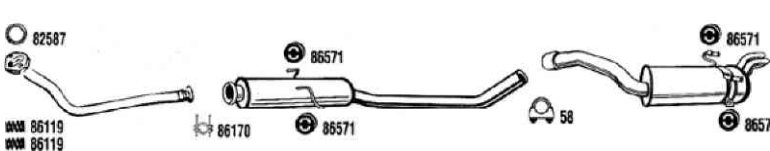

Evasion / Synergie

MPV

1.9 TD

11/94-07/02

1905 cc - 90 HP - 66 kW

Mot/Eng: DHX (XUD9TF/BTF)

Type/Typ: 22, U6

CIT04746B

CAT

1705 R7
9221584CAT

1717 55
613193
MK 85508

1726 92
613191
MK 85509

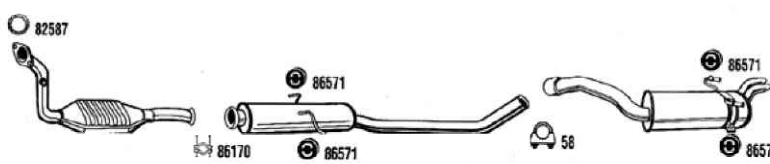

● En desarrollo

Los nombres y números de primer equipo se utilizan solamente como referencia

IMPORTANTE:

Al pedir sistemas de escape, rogamos completen la referencia comenzando por 'MFO.' (ejemplo: 381394 → MFO.381394)

Pour commander echappement, nous vous prions de compléter la référence en commençant par MFO..

When ordering exhaust, please complete the reference by beginning with MFO..

1705 ER 9220546CAT MK 21827	1717 55 613193 MK 85508	1726 92 613191 MK 85509
-----------------------------------	-------------------------------	-------------------------------

Evasion / Synergie MPV
2.0 HDI
08/99-05/00
1997 cc - 109 HP - 80 kW
Mot/Eng: RHZ (DW10ATED)
Type/Typ: 22, U6
CIT13862A CAT

1705 ER 9220546CAT MK 21827	1717 J6 610576	1726 HT 610606 MK 85509
-----------------------------------	-------------------	-------------------------------

Evasion / Synergie MPV
2.0 HDI
05/00-07/02
1997 cc - 109 HP - 80 kW
Mot/Eng: RHZ (DW10ATED)
Mot/Eng: RHW (DW10ATED)
Type/Typ: 22, U6
CIT13862B CAT

1705 N1 9221585CAT MK 21827	1717 55 613193 MK 85508	1726 92 613191 MK 85509
-----------------------------------	-------------------------------	-------------------------------

Evasion / Synergie MPV
2.1 TD
05/96-07/02
2088 cc - 109 HP - 80 kW
Mot/Eng: P8C (XUD11BTE)
Type/Typ: 22, U6
CIT05713 CAT

HY1821 N.D.	HY182901A N.D.	HY182201A N.D.	HY1824 6201111
----------------	-------------------	-------------------	-------------------

Fourgon H H-HZ-HY Bus
1.9
11/69-12/77
1911 cc - 52 HP - 38 kW
1000, 1600 kg
CI82003

GX0414104A 1326-D	95539069 N.D.	GX0415201B 31329	GX0524601A 1330-R(B) MK 85029
----------------------	------------------	---------------------	-------------------------------------

GS-GSX
1.0, 1.1, 1.2, 1.3
08/72-12/79
1015, 1124, 1222, 1299 cc - 55, 56, 60, 65 HP - 40, 41, 44, 48 kW
(A) Altern. (B) - (C) Altern.
Type/Typ: GX serie GA/GB/GH/GE/GC/GL
TSN: 304-306-307-308-378-379
CI60023

GX0414104A 1326-D	95539069 N.D.(A)	GX0415201B 31329	95493053 5301132 MK 85029
----------------------	---------------------	---------------------	---------------------------------

GSA
1.1
06/80-12/83
1124 cc - 56 HP - 41 kW
(A) Altern. Autom. (B) Altern. (C) Altern.
Type/Typ: GX serie YA/YE
TSN: 397
CI60006

Los nombres y números de primer equipo se utilizan solamente como referencia ● En desarrollo

IMPORTANTE:

Al pedir sistemas de escape, rogamos completen la referencia comenzando por 'MFO.' (ejemplo: 381394 → MFO.381394)

Pour commander echappement, nous vous prions de compléter la référence en commençant par MFO..



When ordering exhaust, please complete the reference by beginning with MFO..

ESCAPE / ECHAPPEMENT / EXHAUST

Citroën

Fonos



GSA

Club-Pallas-X3 
 1.3
 09/79-05/80
 1299 cc - 65 HP - 48 kW
 (A)  Autom.-Autom. (B)  (C) Altern.
 Type/Typ: GX serie YL/YR/YS/MY/GF
 TSN: 392-393



CI60007

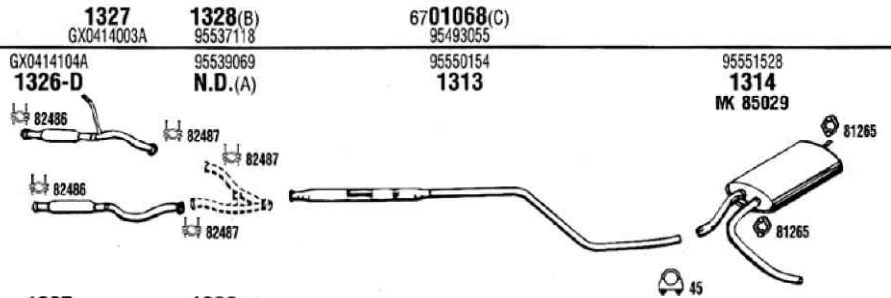

GSA

Club-Pallas-X3 
 1.3
 06/80-07/86
 1299 cc - 65 HP - 48 kW
 (A)  Autom.-Autom. (B) 
 Type/Typ: GX serie YL/YM/YR/YS/YV
 TSN: 355-356-357-359



CI60008

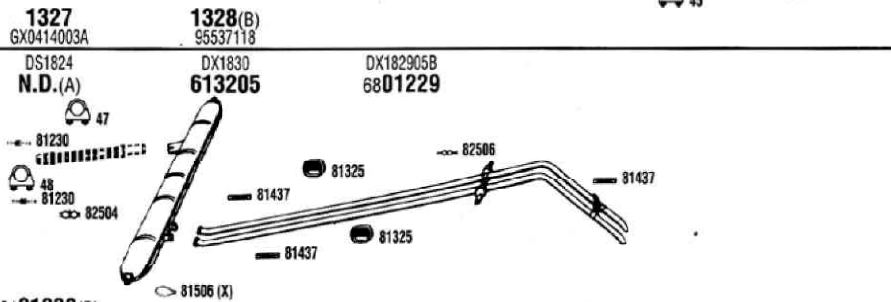

ID19-ID20-DS19-DS20

  -Cabrio
 1.9, 2.0, 2.0
 10/68-09/74
 1911, 1985, 1985 cc - 80, 85, 90 HP - 59, 63, 66 kW
 (A) Inox - (B) Galva
 Type/Typ: DS-20-20-M-ID-19-B-D-ID-20-F-D
 TSN: 341-342-343-345-348-353-
 TSN: 355-356-357-359



CI75003

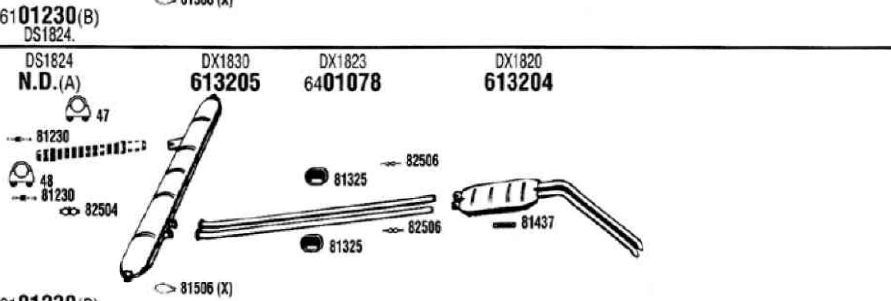

ID21-DS21, DS23

  -Cabrio
 2.1, 2.3
 10/68-09/74
 2175, 2347 cc - 109, 141 HP - 80, 104 kW
 (A) Inox
 (B) Galva
 Type/Typ: DS-20-20-M-ID-19-B-D-ID-20-F-D
 TSN: 343-353



CI75004

ID19, DS19

  -Cabrio
 1.9, 2.0
 01/66-09/68
 1911, 1985 cc - 80, 90 HP - 59, 66 kW
 (A) Inox
 (B) Galva

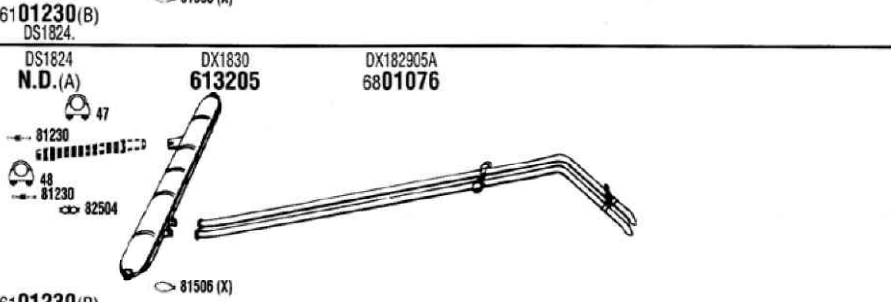

CI75002

Jumper

2.0
 03/94-01/02
 1998 cc - 110 HP - 81 kW
 Mot/Eng: XU10J2U
 Type/Typ: 231A-232B-233B-232J-232K-231C
 TSN: 245
 λ¹-(ch.no.->15267330)
 λ²-(ch.no.152267331->)

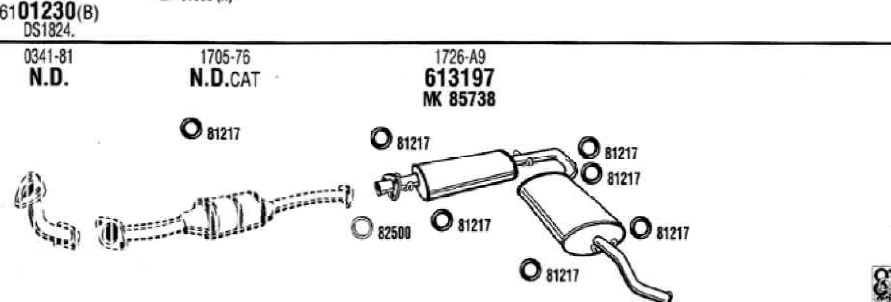

CI90000

CAT

λ¹ 87854 87910 87999x2 λ² 87854 87912 87999

7319290

● En desarrollo

Los nombres y números de primer equipo se utilizan solamente como referencia

IMPORTANTE:

Al pedir sistemas de escape, rogamos completen la referencia comenzando por 'MFO.' (ejemplo: 381394 → MFO.381394)
 Pour commander echappement, nous vous prions de compléter la référence en commençant par MFO..
 When ordering exhaust, please complete the reference by beginning with MFO..

Fonos

Citroën

0341-85 N.D.	1705-77 6319286	1726-A9 613197 MK 85738
-----------------	--------------------	-------------------------------

7319290

Jumper
1.9 Diesel
02/94-01/02
1905 cc - 71 HP - 51 kW
Mot/Eng: XUD9AU
Type/Typ: 23162-23262-23362

CI90003

0341-85 N.D.	1705CK 9320673CAT	1726-A9 613197 MK 85738
-----------------	----------------------	-------------------------------

7319290

Jumper
1.9 Diesel
98-01/02
1905 cc - 70 HP - 51 kW
Mot/Eng: XUD9

CI90025 **CAT**

1705-78 6319283		1726-A9 613197 MK 85738
--------------------	--	-------------------------------

7319290

Jumper
Van 100 - 140
1.9 TD
02/94-01/02
1905 cc - 92 HP - 68 kW
Mot/Eng: XUD9UTF
Type/Typ: 231A72

CI90007

034-176 N.D.	1705W7 ● 613790	1726-A9 613197 MK 85738
-----------------	--------------------	-------------------------------

7319290

Jumper
1.9 TD
02/94-01/02
1905 cc - 90 HP - 66 kW
Mot/Eng: XUD9TE

CI90031

1705-79 N.D.CAT		1726-A9 613197 MK 85738
--------------------	--	-------------------------------

7319290

Jumper
1.9 TD
02/94-01/02
1905 cc - 90 HP - 66 kW
Mot/Eng: XUD9TE

CI90001 **CAT**

0341-81 N.D.	1705-76 N.D.CAT	1726-A9 613197 MK 85738
-----------------	--------------------	-------------------------------

7319290

Jumper
Van - Combi - Chassis Cabin
100 - 140 - 18Q
2.0i
02/94-01/02
1998 cc - 110 HP - 81 kW
Mot/Eng: XU10J2U
Type/Typ: 231A22
λ¹=(ch.no.->15267330)
λ²=(ch.no.152267331->)

CI90004 **CAT**

λ¹ 87854 87910 87999x2 λ² 87854 87912 87999

Los nombres y números de primer equipo se utilizan solamente como referencia

● En desarrollo

IMPORTANTE:

Al Al pedir sistemas de escape, rogamos completen la referencia comenzando por 'MFO.' (ejemplo: 381394 → MFO.381394)
Pour commander echappement, nous vous prions de compléter la référence en commençant par MFO..
When ordering exhaust, please complete the reference by beginning with MFO..

ESCAPE / ECHAPPEMENT / EXHAUST

Citroën

Jumper

Van - Chassis Cabin - Chassis
140 - 180

2.5 Diesel
02/94-01/02
2445 cc - 86 HP - 63 kW
Mot/Eng: DJ5
Type/Typ: 231B52

1705-78
63**19283**

1726-A9
613197
MK 85738

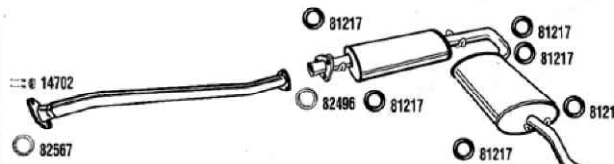

73**19290**

CI90009

Jumper

2.5 Diesel
02/94-01/02
2445 cc - 86 HP - 63 kW
Mot/Eng: DJ5

034.176
N.D.

1705W7
● **613790**

1705CS
91**20677**CAT

1726CF
N.D.

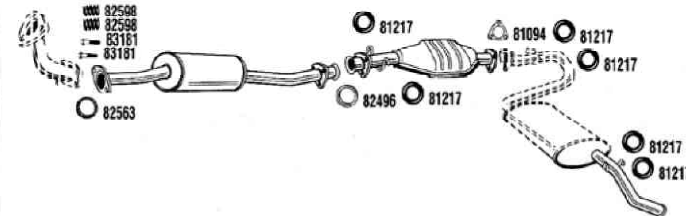

CI90033

CAT



Jumper

Van - Chassis Cabin
2.5 TD

02/94-01/02
2445 cc - 103 HP - 76 kW
Mot/Eng: DJ5T
Type/Typ: 231B92

0341-77
N.D.

1705-78
63**19283**

1726-A9
613197
MK 85738

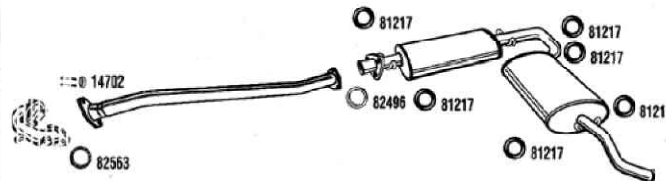

73**19290**

CI90012

Jumper

2.5 TD
02/94-01/02
2445 cc - 100 HP - 74 kW
Mot/Eng: DJ5T
Type/Typ: 23102-23202-23292

0341-77
N.D.

1705-80
93**20443**CAT

1726-A9
613197
MK 85738

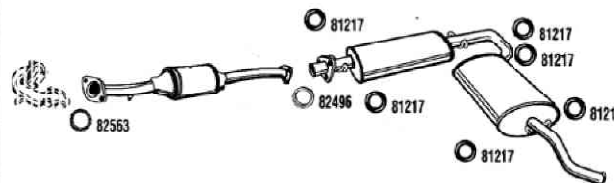

73**19290**

CI90002

CAT

Jumper

Van
2.5 TDi
07/96-01/02
2446 cc - 107 HP - 79 kW
Mot/Eng: DJ5TED

0341-77
N.D.

1705-78
63**19283**

1726-A9
613197
MK 85738

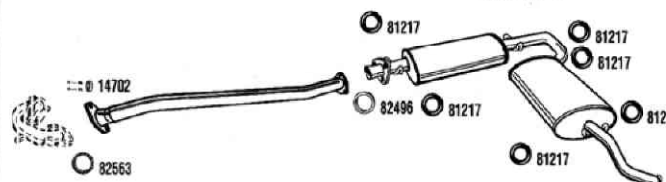

73**19290**

CI90018

Jumper

Van
2.5 TDi
98-01/02
2446 cc - 107 HP - 79 kW
Mot/Eng: DJ5TED

0341-77
N.D.

1705-80
93**20443**CAT

1726-A9
613197
MK 85738

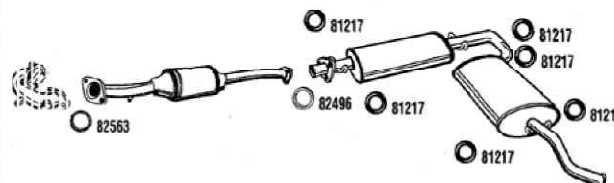

CI90026

CAT

● En desarrollo

Los nombres y números de primer equipo se utilizan solamente como referencia

IMPORTANTE:

Al pedir sistemas de escape, rogamos completen la referencia comenzando por 'MFO.' (ejemplo: 381394 → MFO.381394)
Pour commander echappement, nous vous prions de compléter la référence en commençant par MFO..
When ordering exhaust, please complete the reference by beginning with MFO..

Fonos

Citroën

0341E9 N.D.	1705FH ●9320652CAT	1726FR N.D.
----------------	-----------------------	----------------

Jumper Van
2.8 Diesel
06/99-01/02
2798 cc - 87 HP - 64 kW
Mot/Eng: 8140-63
Type/Typ: 232

CI90030 **CAT**

1705 F1 9221586CAT	1717 53 613187 MK 85467	1726 G9 613587 MK 85509
-----------------------	-------------------------------	-------------------------------

Jumpy / Dispatch MPV, Box
1.6
10/95-
1581 cc - 79 HP - 58 kW
Mot/Eng: 1580 SPI, 220 A2.000
Type/Typ: U6U

CIW91030 **CAT**

1705 JR 9320593CAT(A)	1717 L0 613288(A) MK 85880	1726HX 613791
--------------------------	----------------------------------	------------------

Jumpy / Dispatch MPV, Box
2.0
04/00-
1997 cc - 136 HP - 100 kW
Type/Typ: U6U
To: (A) -06/01
From: (B) 06/01-

CIW91031 **CAT**

1721 28 613509	1705 P7 613588 MK 85765	1726 G9 613587 MK 85509
-------------------	-------------------------------	-------------------------------

Jumpy / Dispatch MPV
1.9 Diesel
10/95-04/98
1905 cc - 69 HP - 51 kW
Mot/Eng: D9B (XUD9A/U)
Type/Typ: U6U

CIT05554

1705 AF 9320345CAT(A) MK 21644	1717 53 613187(A) MK 85467	1726 G9 613587(A) MK 85509
--------------------------------------	----------------------------------	----------------------------------

Jumpy / Dispatch MPV, Box
1.9 Diesel
04/98-
1868 cc - 69 HP - 51 kW
Mot/Eng: WJZ (DWB)
Type/Typ: 11611
To: (A) -05/00
From: (B) 06/00-
Wheelbase: SWB

CIW91032 **CAT**

1705NS ●610778	1705NT 9220653CAT(A)	1726HS 613755 MK 85881
-------------------	-------------------------	------------------------------

Jumpy / Dispatch MPV, Box
1.9 Diesel
09/01-
1868 cc - 69 HP - 51 kW
Mot/Eng: WJY (DWB)
Type/Typ: U6U
Wheelbase: (A) SWB

CIW91033 **CAT**

Los nombres y números de primer equipo se utilizan solamente como referencia

● En desarrollo

IMPORTANTE:

Al pedir sistemas de escape, rogamos completen la referencia comenzando por 'MFO.' (ejemplo: 381394 → MFO.381394)
Pour commander echappement, nous vous prions de compléter la référence en commençant par MFO..
When ordering exhaust, please complete the reference by beginning with MFO..

ESCAPE / ECHAPPEMENT / EXHAUST

Fonos

MOTOR / MOTEUR / ENGINE

Citroën

Jumpy / Dispatch

MPV, Box
1.9 Diesel
04/98-
1868 cc - 69 HP - 51 kW
Mot/Eng: WJZ (DW8)
Type/Typ: U6U
To: (A) -05/00
From: (B) 06/00-
Wheelbase: LWB

CIW91034 **CAT**

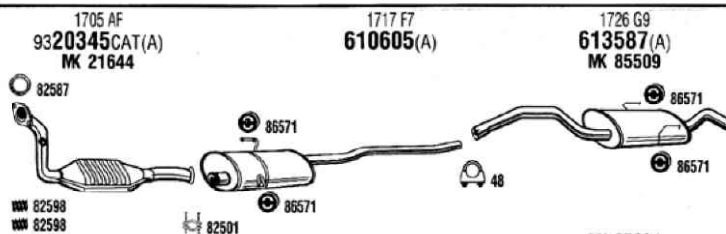

9320645CAT(B) 1705JN 613760(B) 1717J7 MK 85881 613755(B) 1726HS

Jumpy / Dispatch

MPV
1.9 TD
04/96-
1905 cc - 92 HP - 68 kW
Mot/Eng: D8B (XUD9TF)
Type/Typ: U6U

CIT05553 **CAT**

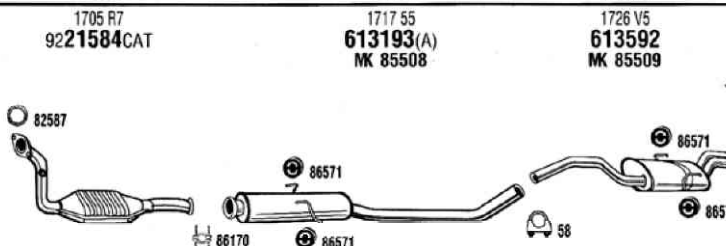

Jumpy / Dispatch

MPV, Box
1.9 TD
10/95-
1905 cc - 90 HP - 66 kW
Mot/Eng: DHX (XUD9TF/BTF)
Type/Typ: U6U
Wheelbase: (A) SWB
Wheelbase: (B) LWB

CIW91035 **CAT**

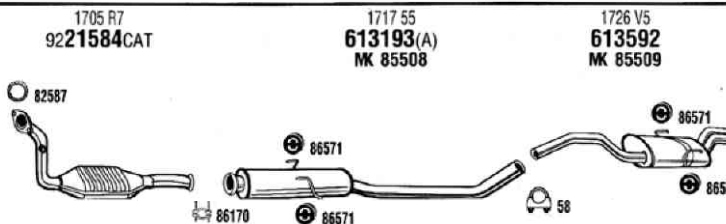

MK 85508 610604(B) 1717 F5

Jumpy / Dispatch

Flatbed , Chassis
1.9 TD
10/99-
1905 cc - 92 HP - 68 kW
Wheelbase: (A) SWB
Wheelbase: (B) LWB

CIT15093 **CAT**

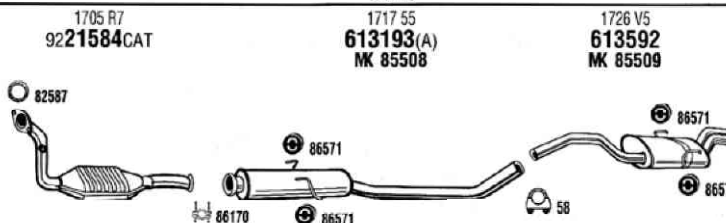

MK 85508 610604(B) 1717 F5

Jumpy / Dispatch

MPV, Box
2.0 HDi
10/99-06/01
1997 cc - 94 HP - 69 kW
Mot/Eng: RHX
Type/Typ: U6U
Wheelbase: SWB

CIW91036 **CAT**

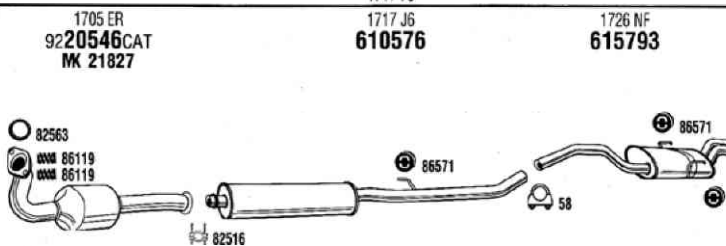

Jumpy / Dispatch

MPV, Box
2.0 HDi
06/01-
1997 cc - 94 HP - 69 kW
Mot/Eng: RHX
Type/Typ: U6U
Wheelbase: SWB

CIW91037 **CAT**

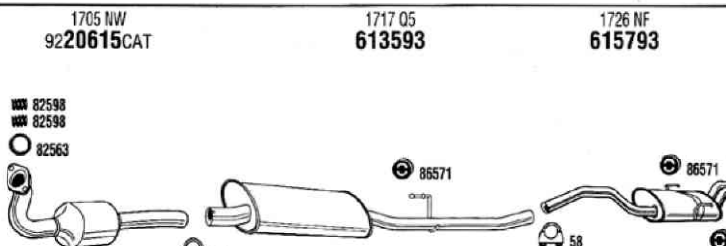

● En desarrollo

Los nombres y números de primer equipo se utilizan solamente como referencia

IMPORTANTE:

Al pedir sistemas de escape, rogamos completen la referencia comenzando por 'MFO.' (ejemplo: 381394 → MFO.381394)

Pour commander echappement, nous vous prions de compléter la référence en commençant par MFO..

When ordering exhaust, please complete the reference by beginning with MFO..

Fonos

Citroën

1705 ER
9220546CAT
MK 21827

1717J7
613760

1726 NF
615793

Jumpy / Dispatch
Box
2.0 HDi
10/99-06/01
1997 cc - 94 HP - 69 kW
Wheelbase: LWB

CIW91038 **CAT**

1705 NW
9220615CAT

1717Q6
613761

1726 NF
615793

Jumpy / Dispatch
Box
2.0 HDi
06/01-
1997 cc - 94 HP - 69 kW
Wheelbase: LWB

CIW91039 **CAT**

1705 ER
9220546CAT
MK 21827

1717J6
610576(A)

1726 NF
615793

Jumpy / Dispatch
MPV, Box
2.0 HDi
03/00-06/01
1997 cc - 109 HP - 80 kW
Mot/Eng: RHZ (DW10ATED)
Type/Typ: U6J
Wheelbase: (A) SWB

CIW91040 **CAT**

1705 NW
9220615CAT

1717Q5
613593(A)

1726 NF
615793

Jumpy / Dispatch
MPV, Box
2.0 HDi
06/01-
1997 cc - 109 HP - 80 kW
Mot/Eng: RHZ (DW10ATED)
Type/Typ: U6J
Wheelbase: (A) SWB
Wheelbase: (B) LWB

CIW91041 **CAT**

1705NX
N.D.CAT

1717Q5
613593(A)

1726 NF
615793

Jumpy
Van , Chassis Cabine
2.0 HDi
01/02-
1997 cc - 110 HP - 81 kW
Mot/Eng: RHZ (DW10CTED)
Type/Typ: B*
Wheelbase: (A) SWB

CIP91021 **CAT**

1705 NW
9220615CAT

1717Q5
613593(A)

1726 HT
610606
MK 85509

Jumpy
Van
2.0 HDi
06/01-
1997 cc - 110 HP - 81 kW
Mot/Eng: DW10ATED
(A) SWB - (B) LWB

CI91016 **CAT**

Los nombres y números de primer equipo se utilizan solamente como referencia

● En desarrollo

IMPORTANTE:

Al pedir sistemas de escape, rogamos completen la referencia comenzando por 'MFO.' (ejemplo: 381394 → MFO.381394)
Pour commander echappement, nous vous prions de compléter la référence en commençant par MFO..
When ordering exhaust, please complete the reference by beginning with MFO..

ESCAPE / ECHAPPEMENT / EXHAUST

Fonos

Citroën

LN

Hatchback

0.6

07/77-07/79

652 cc - 32 HP - 24 kW

Type/Typ: RB serie RB

TSN: 376

5484445
31374

75492020
6501050

5490971
631377
MK 85172

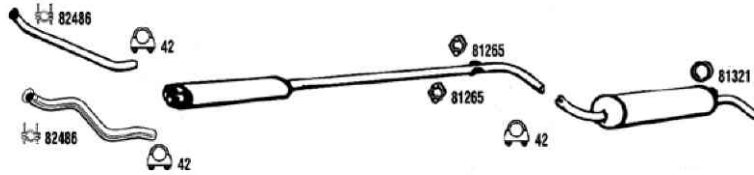

1375
75510897

7301052

CI41002

LNA

Club Hatchback

0.6

11/78-12/86

652 cc - 34, 36 HP - 25, 26 kW

Type/Typ: RB serie RD/RE/RF

TSN: 384-394

5484445
31374

75517968
631376

5490971
631377
MK 85172

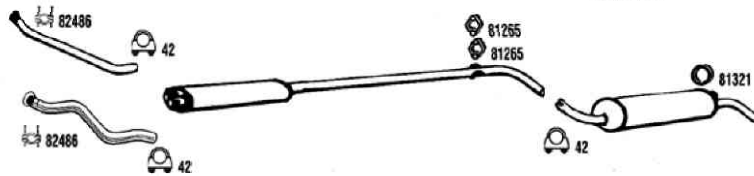

1375
75510897

7301052

CI41003

LNA (1)

Hatchback

1.0

01/84-08/86

954 cc - 45 HP - 33 kW

9150246280
1378

7910032651
1379

9150995880
631232
MK 85029

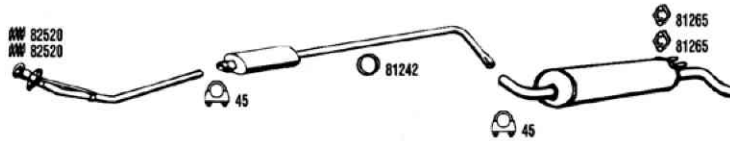

7301129

CI41006

LNA

11E-RE-RS Hatchback

1.1

07/82-12/86

1124 cc - 50 HP - 37 kW

Type/Typ: RB serie RG/RGA/RH

TSN: 404

9150246280
1378

7910032651
1379

9150995880
631232
MK 85029

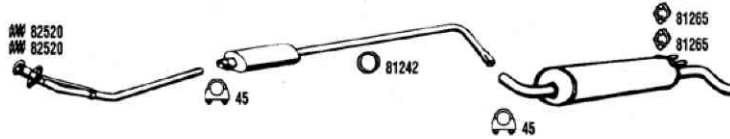

7301129

CI41004

LNA

Hatchback

1.1

02/83-86

1124 cc - 50 HP - 37 kW

91510622
6601475

9750817980
613913
MK 85362



7301517

CI41005

Mehari

4x4 Azur - Pick up

0.6

09/68-08/87

602 cc - 28, 33 HP - 21, 24 kW

4x4 - 08/83

Azur: 04/83-

Type/Typ: AY serie CA-AY serie CE

75527203
613206

AY1824
31321

AY1820
631332

AZU18293
31324

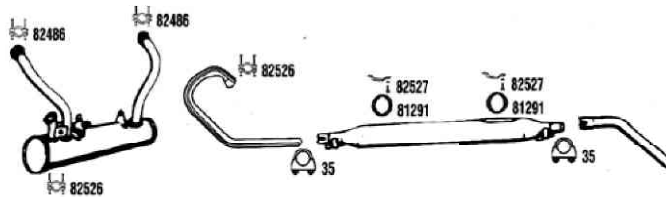

7301031

CI30003

● En desarrollo

Los nombres y números de primer equipo se utilizan solamente como referencia

IMPORTANTE:

Al pedir sistemas de escape, rogamos completen la referencia comenzando por 'MFO.' (ejemplo: 381394 → MFO.381394)

Pour commander echappement, nous vous prions de compléter la référence en commençant par MFO..

When ordering exhaust, please complete the reference by beginning with MFO..

Fonos

Citroën

1705 44 61 04064	1731-65 97 19172 CAT MK 19240	1726-L1 61 3153 MK 85009
----------------------------	--	---------------------------------------

65 98751 (A) 1732-12S	65 04068 (B) 1732 12B	65 08138 (C) 1731 53(RP)
---------------------------------	---------------------------------	------------------------------------

87854	87912	87853	87905	87998
-------	-------	-------	-------	-------

7317172

Saxo X
1.0i
02/96-06/00
954 cc - 50 HP - 37 kW
Mot/Eng: TU9M
(A) repair pipe dia.42.5mm - (B) repair pipe dia.36.5mm
(C) repair pipe dia.38.5mm
Type/Typ: SOCDZE/SOCDZF/S1CDZE/S1CDZF
TSN: 282
λ¹=02/96-09/98 - λ²=10/98-06/00
CI21000 **CAT**

1705 19 61 07174	1731-65 97 19172 CAT MK 19240	1726-L1 61 3153 (A) MK 85009	1726 S3 61 3188 (B) MK 85009
----------------------------	--	---	---

65 98751 (C) 1732-12S	65 04068 (D) 1732 12B	65 08138 (E) 1731 53(RP)
---------------------------------	---------------------------------	------------------------------------

87854	87912	87853	87905	87998
-------	-------	-------	-------	-------

7317172

Saxo X - SX
1.1i
02/96-06/00
1124 cc - 60 HP - 44 kW
Mot/Eng: TU1M
DEPOL CEE 19-5 - (A)=W/O, (B)=W/ Chrome tail pipe
(C) repair pipe dia.42.5mm - (D) repair pipe dia.36.5mm
(E) repair pipe dia.38.5mm
Type/Typ: SO, S1 - TSN: 283-284-285
λ¹=02/96-09/98 - λ²=10/98-06/00
CI21013 **CAT**

1705 44 61 04064	1731-65 97 19172 CAT MK 19240	1726-L1 61 3153 (A) MK 85009	1726 S3 61 3188 (B) MK 85009
----------------------------	--	---	---

65 98751 (C) 1732-12S	65 04068 (D) 1732 12B	65 08138 (E) 1731 53(RP)
---------------------------------	---------------------------------	------------------------------------

87854	87912	87853	87905	87998
-------	-------	-------	-------	-------

7317172

Saxo X - SX
1.1i
02/96-06/00
1124 cc - 60 HP - 44 kW
Mot/Eng: TU1M
DEPOL CEE95 - (A)=W/O, (B)=W/ chrome tail pipe
(C) repair pipe dia.42.5mm - (D) repair pipe dia.36.5mm
(E) repair pipe dia.38.5mm
Type/Typ: SOHDZE/SOHDZF/S1HDZE/S1HDZF
λ¹=02/96-09/98 - λ²=10/98-06/00
CI21001 **CAT**

1705 19 61 07174	1731-65 97 19172 CAT MK 19240	1726-L1 61 3153 (A) MK 85009	1726 S3 61 3188 (B) MK 85009
----------------------------	--	---	---

65 98751 (C) 1732-12S	65 04068 (D) 1732 12B	65 08138 (E) 1731 53(RP)
---------------------------------	---------------------------------	------------------------------------

87854	87919
-------	-------

Saxo X - SX
1.1i
02/96-06/00
1124 cc - 60 HP - 44 kW
Mot/Eng: TU1M - DEPOL 15-04
(A) = W/O, (B) = W/ Chrome tail pipe
(C) repair pipe dia.42.5mm - (D) repair pipe dia.36.5mm
(E) repair pipe dia.38.5mm
Type/Typ: SOHDZE/SOHDZF/S1HDZE/S1HDZF
TSN: 283-284 - Depol 15-04
CI21014 **CAT**

1731 N9 92 20627 CAT	1717 T0 67 07150	1726 LF 61 3423 MK 85933
--------------------------------	----------------------------	---------------------------------------

Saxo
1.1
07/00-
1124 cc - 60 HP - 44 kW
Mot/Eng: TU1JP
Type/Typ: SOHFXB-S1HFXB
CI21024 **CAT**

1705 65 61 07172	1731 E3 92 19173 CAT MK 87216	1717 A3 61 3160 MK 85460	1726-L1 61 3153 (A) MK 85009
----------------------------	--	---------------------------------------	---

61 3188 (B) 1726 S3

7317173

Saxo
1.4i
02/96-
1360 cc - 75 HP - 55 kW
Mot/Eng: TU3JP
(A) = W/O chrome, (B) = W/ chrome tail pipe
DEPOL CEE 95
Type/Typ: SOKFXF/S1KFXF - TSN: 285
CI21002 **CAT**

Los nombres y números de primer equipo se utilizan solamente como referencia

● En desarrollo

IMPORTANTE:

Al pedir sistemas de escape, rogamos completen la referencia comenzando por 'MFO.' (ejemplo: 381394 → MFO.381394)
Pour commander echappement, nous vous prions de compléter la référence en commençant par MFO..
When ordering exhaust, please complete the reference by beginning with MFO..

ESCAPE / ECHAPPEMENT / EXHAUST

MOTOR / MOTEUR / ENGINE

Citroën

Fonos

Saxo
1.4i
02/96-
1360 cc - 75 HP - 55 kW
Mot/Eng: TU3JP
(A) = W/O chrome & (B) W/ chrome
Depol. CEE 95
Type/Typ: S0-S1 - TSN: 285
λ¹-Depol. EUR095/EURO96

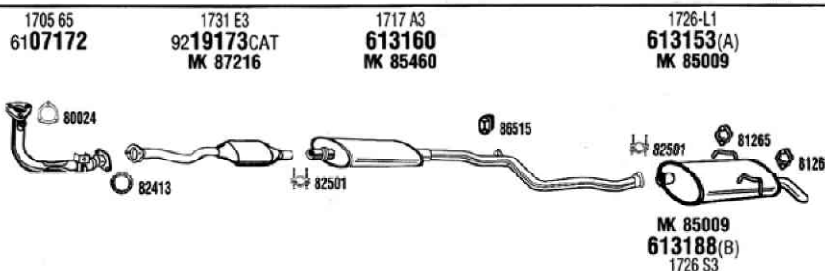

CI21007 **CAT**

λ¹ 87854 87912

Saxo
1.4i
02/96-
1360 cc - 75 HP - 55 kW
Mot/Eng: TU3JP
DEPOL 15-04
RS = W/O chrome tail pipe
Type/Typ: S0KXF/S1KFXF
TSN: 285
λ¹-Depol 15-04

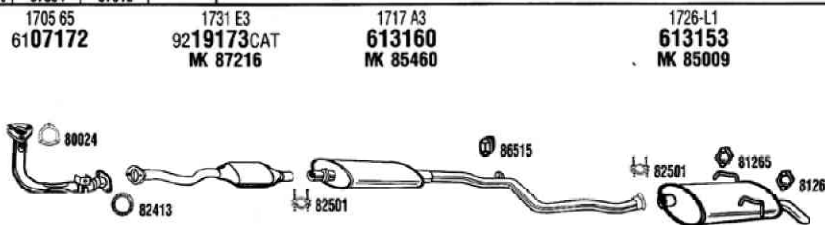

CI21010 **CAT**

λ¹ 87854 87919

Saxo
1.4i
02/96-
1360 cc - 75 HP - 55 kW
Mot/Eng: TU3JP
DEPOL CEE 2000
RS = W/O chrome tail pipe
Type/Typ: S0KXF/S1KFXF
TSN: 285

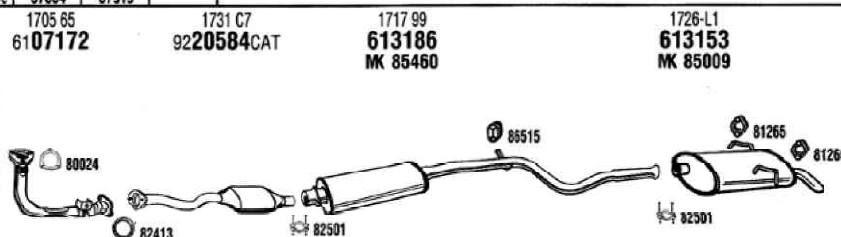

CI21009 **CAT**

Saxo
1.4
05/96-
1360 cc - 75 HP - 55 kW
Mot/Eng: TU3JP
Depol. L4 - Depol. K PRIM
(A) W/O chrome tail pipe
(B) W/ chrome tail pipe
Type/Typ: S0-S1

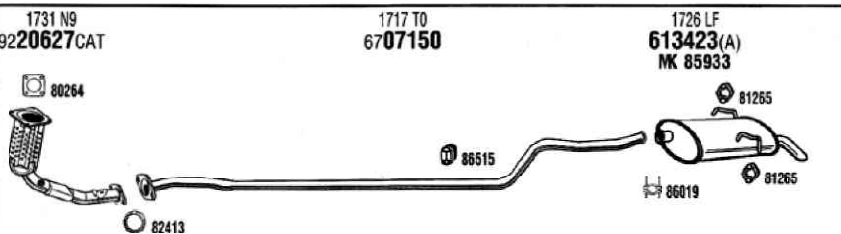

CI21025 **CAT**

N.D. (B)
1726 JV

Saxo
1.6i
02/96-
1587 cc - 90 HP - 66 kW
Mot/Eng: TU5JP
DEPOL CEE 95
(A) = W/O Chrome tail pipe
(B) = W/ Chrome tail pipe
Type/Typ: S0NFZF/S0NFZD/S1NFZD/S6NFZF - TSN: 285
λ¹-02/96->09/98
λ²-10/98->

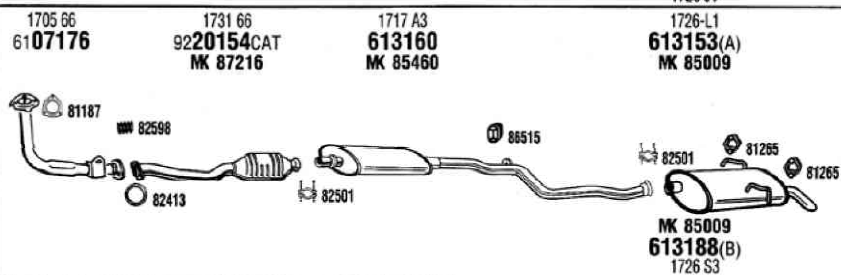

CI21003 **CAT**

λ¹ 87854 87912 λ² 87853 87905 87998

7317173

Saxo
1.6i
02/96-
1587 cc - 90 HP - 66 kW
Mot/Eng: TU5JP
DEPOL 15-04
RS = ONLY W/O chrome tail pipe
Type/Typ: S0NFZF/S0NFZD/S1NFZD/S6NFZF
TSN: 286
λ¹-Depol 15-04

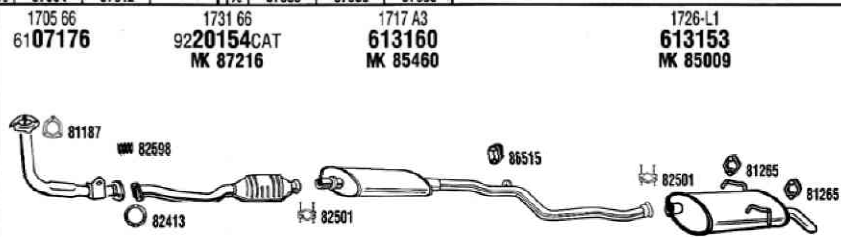

CI21008 **CAT**

λ¹ 87854 87919

● En desarrollo

Los nombres y números de primer equipo se utilizan solamente como referencia

IMPORTANTE:

Al pedir sistemas de escape, rogamos completen la referencia comenzando por 'MFO.' (ejemplo: 381394 → MFO.381394)
Pour commander echappement, nous vous prions de compléter la référence en commençant par MFO..
When ordering exhaust, please complete the reference by beginning with MFO..

1705 L5 N.D.	1731 66 9220154CAT(A) MK 87216	1717 66 613165 MK 85460	1726 L2 613166 MK 85006
-----------------	--------------------------------------	-------------------------------	-------------------------------

N.D.CAT(B)
1731 G5

87854	87912
-------	-------

Saxo
Hatchback
1.6i 16v DOHC
02/96-
1587 cc - 120 HP - 88 kW
Mot/Eng: TU5JP4
(A) Depol. CEE 95 (L3)
(B) Depol. CEE 2000 (D3)
Type/Typ: S6 - TSN: 293

CI21006 **CAT**

1705 KQ N.D.	1731 P3 9220674CAT	1717 N1 613424	1726 L2 613166 MK 85006
-----------------	-----------------------	-------------------	-------------------------------

87854	87912
-------	-------

Saxo
Hatchback
1.6i 16v DOHC
09/00-
1587 cc - 120 HP - 88 kW
Mot/Eng: TU5JP4
Depol. CEE 2000 (L4)
Type/Typ: S6 - TSN: 293

CI21028 **CAT**

1731 P4 N.D.CAT	1717 79 615129	1726 S3 613188 MK 85009
--------------------	-------------------	-------------------------------

Saxo
1.6 VTS
02/01-
1587 cc - 98 HP - 72 kW
Mot/Eng: TU5JP
Depol. L4
Type/Typ: S6NFTB

CI21026 **CAT**

1705 93 6205322	1717 79 615129	1726-L1 613153 MK 85009
--------------------	-------------------	-------------------------------

Saxo
1.5 Diesel
02/96-
1527 cc - 57 HP - 42 kW
Mot/Eng: TUD5
Type/Typ: S3

CI21012

1705 93 6205322	1731 A3 9720543CAT	1726-L1 613153 MK 85009
--------------------	-----------------------	-------------------------------

Saxo
1.5 Diesel
05/96-01/99
1527 cc - 57 HP - 42 kW
Mot/Eng: TUD5
Type/Typ: S0.S1
TSN: 287-294
Emission EURO II

CI21011 **CAT**

1705 93 6205322	1731 J2 9720671CAT	1726-L1 613153 MK 85009
--------------------	-----------------------	-------------------------------

Saxo
1.5 Diesel
02/99-07/03
1527 cc - 57 HP - 42 kW
Mot/Eng: TUD5
Type/Typ: S0.S1
TSN: 287-294
Emission EURO III

CI21027 **CAT**

Los nombres y números de primer equipo se utilizan solamente como referencia

● En desarrollo

IMPORTANTE:

Al pedir sistemas de escape, rogamos completen la referencia comenzando por 'MFO.' (ejemplo: 381394 → MFO.381394)
Pour commander echappement, nous vous prions de compléter la référence en commençant par MFO..
When ordering exhaust, please complete the reference by beginning with MFO..

ESCAPE / ECHAPPEMENT / EXHAUST

Fonos

MOTOR / MOTEUR / ENGINE

Citroën

Visa

Club-Spécial Hatchback

0.6 2 cyl.

06/78-06/88

652 cc - 33, 34, 36 HP - 24, 25, 26 kW

Spécial: -07/83

Type/Typ: VD serie VAN/VNJ

TSN: 382-392-395-437

75527066
1355

75510952
631356

75510953
631357
MK 85121

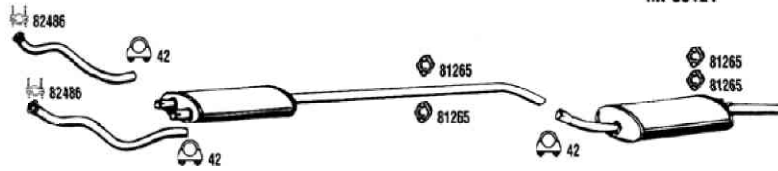

31354
5503269

7301057

CI50003

Visa (F) (I)

10E Hatchback

1.0 4 cyl.

01/83-06/88

954 cc - 45 HP - 33 kW

Ⓢ: 06/86-

Type/Typ: VD serie PC

9150246180
31348

91519172
631349

7910030845
631350
MK 85029

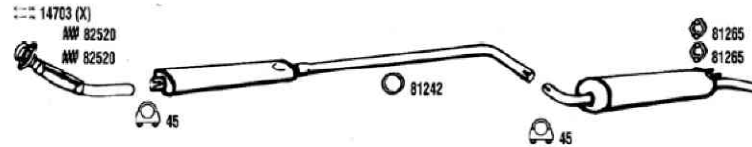

7301129

CI50012

Visa

11E-RE-Super Hatchback

Carte Noire-Décapotable-Leader-Olympique-Platine-Sextant-West End

1.1 4 cyl.

06/78-06/88

1124 cc - 50 HP - 37 kW

Type/Typ: VD serie VBAVG

TSN: 402

CI50004

9150246180
31348

91519172
631349

7910030845
631350
MK 85029

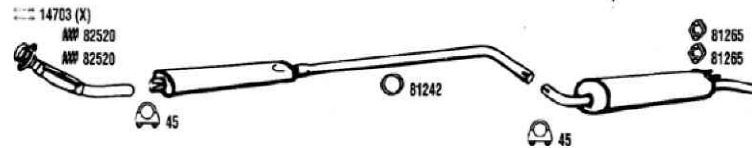

7301129

Visa

GT-Tonic-Chrono-Challenger Hatchback

1.4

07/82-06/86

1360 cc - 80, 90 HP - 58, 66 kW

Tonic: 06/83-, Challenger: 02/85-

(A) excl. Chrono

Type/Typ: VD serie VS

TSN: 405

CI50007

97516727
N.D.(A)

97509938
N.D.

95585992
61337



7301129

Visa

1.4 GT

03/83-06/87

1360 cc - 80 HP - 58 kW

Mot/Eng: 150Z

9150246180
31348

91519172
631349

7910030845
631350
MK 85029

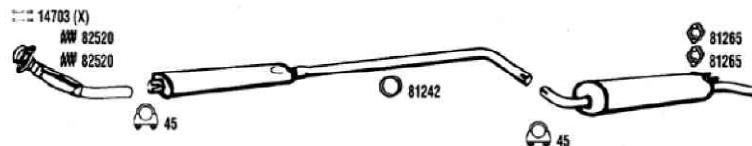

7301129

CI50023

Visa

14TRS Hatchback

1.4

07/84-09/86

1360 cc - 60 HP - 44 kW

Type/Typ: VD serie PE

TSN: 419

95604841
N.D.

95610365
6401221
MK 85029

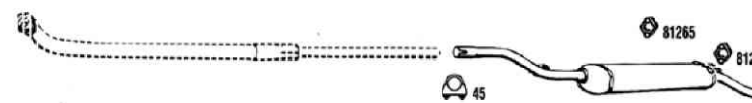

73012797

CI50005

● En desarrollo



Los nombres y números de primer equipo se utilizan solamente como referencia

IMPORTANTE:

Al pedir sistemas de escape, rogamos completen la referencia comenzando por 'MFO.' (ejemplo: 381394 → MFO.381394)

Pour commander echappement, nous vous prions de compléter la référence en commençant par MFO..

When ordering exhaust, please complete the reference by beginning with MFO..

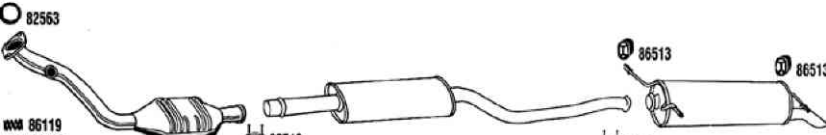
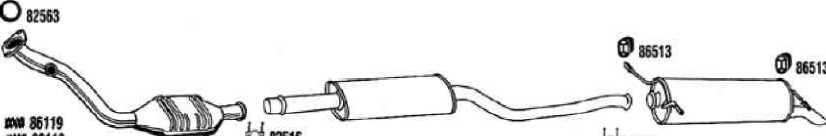
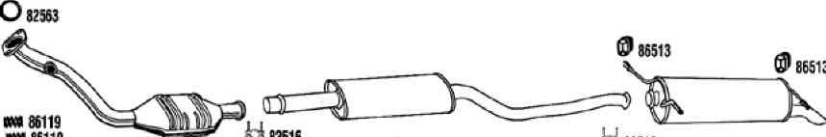
<p>N.D.CAT</p> 	<p>95593036 N.D.</p>	<p>95585992 61337</p>	<p>Visa 14TRS Hatchback 1.4 10/86-06/88 1360 cc - 55 HP - 40 kW Mot/Eng: 150D-XY7 TSN: 419</p>
			<p>CI50015 CAT</p>
<p>95598164 N.D.</p> 	<p>95593036 N.D.</p>	<p>95585830 31347</p>	<p>Visa 16 GTi Hatchback 1.6i 01/85-06/88 1580 cc - 105, 115 HP - 76, 85 kW Mot/Eng: 180-A Type/Typ: VD serie PD TSN: 428</p>
			<p>CI50008</p>
<p>1721 28 613509</p> 	<p>95600360 31384</p>	<p>95593036 N.D.</p>	<p>Visa 17D-RD Hatchback 1.8 Diesel 04/84-06/88 1769 cc - 60 HP - 44 kW Mot/Eng: XUD 7 Type/Typ: VD serie VT TSN: 420</p>
			<p>CI50009</p>
<p>96106848 9220097CAT MK 18473</p> 	<p>96106851 613130</p>	<p>1726 81 613131 MK 85142</p>	<p>Xantia X-SX 1.6i 03/93-12/97 1580 cc - 90 HP - 66 kW Mot/Eng: XU5JP Type/Typ: X1 serie 2B TSN: 236 λ¹=03/93->04/95 λ²=05/95->12/98</p>
			<p>CI65001 CAT</p>
<p>96106848 9220097CAT MK 18473</p> 	<p>96106851 613130</p>	<p>1726 81 613131 MK 85142</p>	<p>Xantia X-SX 1.6i 03/94-11/97 1580 cc - 88 HP - 65 kW Mot/Eng: XU5JP Type/Typ: X1 Serie 2B λ¹=03/94->04/95 λ²=05/95->11/98</p>
			<p>CI65008 CAT</p>
<p>96106848 9220097CAT MK 18473</p> 	<p>96106851 613130</p>	<p>1726 81 613131 MK 85142</p>	<p>Xantia X-SX-VSX 1.8i 8v 03/93-11/97 1761 cc - 101 HP - 74 kW Mot/Eng: XU7JP Type/Typ: X1 Serie 1A/7A/9B TSN: 233 λ¹=03/93->04/95 λ²=05/95->11/98</p>
			<p>CI65002 CAT</p>

Los nombres y números de primer equipo se utilizan solamente como referencia

● En desarrollo

IMPORTANTE:

Al pedir sistemas de escape, rogamos completen la referencia comenzando por 'MFO.' (ejemplo: 381394 → MFO.381394)
 Pour commander echappement, nous vous prions de compléter la référence en commençant par MFO..
 When ordering exhaust, please complete the reference by beginning with MFO..

1705-KO 9220117CAT MK 21672	96106856 613133 MK 85407	96164371 613134 MK 85209
-----------------------------------	--------------------------------	--------------------------------

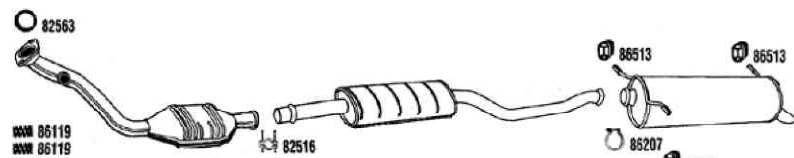

82563
82516
86513
86513
86207
86513

87854 87910 87854 87912

7319005

Xantia Hatchback
2.0i 8v
03/93-01
1998 cc - 121 HP - 89 kW
Mot/Eng: XU10J2C
Type/Typ: X1
TSN: 234
λ¹=03/93->04/95
λ²=05/95->01/98

Ci65004 **CAT**

1705-KO 9220117CAT(A) MK 21672	96106856 613133 MK 85407	96164371 613134 MK 85209
--------------------------------------	--------------------------------	--------------------------------

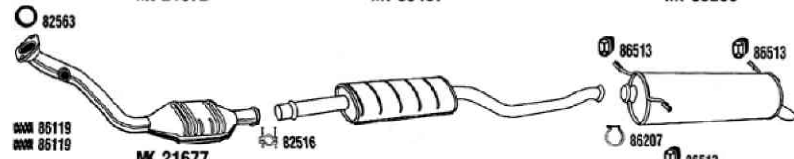

82563
82516
86513
86513
86207
86513

87854 87910 87959x2 87854 87919 87854 87912

7319005

Xantia Hatchback
2.0i 16v
03/93-05/95
1998 cc - 152 HP - 112 kW
Mot/Eng: XU10J4D
(A) Depol. US83 (B) Depol. CEE95 L3
Type/Typ: X1 - TSN: 235
λ¹=Eng.RFY/RFT
λ²=Eng.RFV Depol.15-04
λ³=Eng.RFV exc. Depol.15-04

Ci65003 **CAT**

1731-43 9220474CAT MK 21677	96106856 613133 MK 85407	96164371 613134 MK 85209
-----------------------------------	--------------------------------	--------------------------------

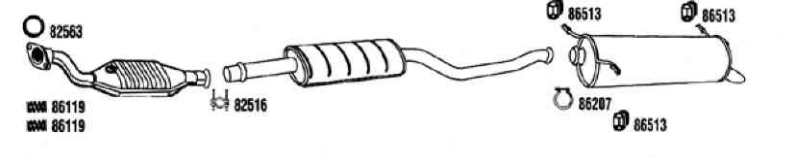

82563
82516
86513
86513
86207
86513

87854 87910 87959x2 87854 87919 87854 87912

7319005

Xantia VSX - Activa
2.0i 16v
03/95-01
1998 cc - 150 HP - 110 kW
Mot/Eng: XU10J4R - ch.no. 06778-
Type/Typ: X15A
λ¹=Eng.RFY/RFT
λ²=Eng.RFV Depol.15-04
λ³=Eng.RFV exc. Depol.15-01

Ci55004 **CAT**

1731-43 9220474CAT(A) MK 21677	1717 56 613473	96164371 613134 MK 85209
--------------------------------------	-------------------	--------------------------------

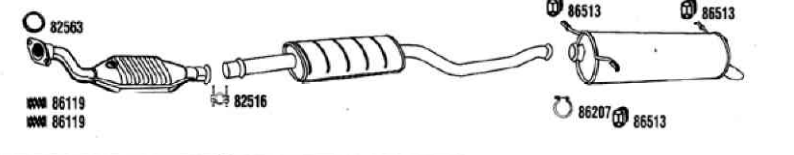

82563
82516
86513
86513
86207
86513

87854 87912 87854 87919

7319005

Xantia Hatchback
2.0i 16v
06/95-01
1998 cc - 133 HP - 98 kW
Mot/Eng: XU10J4R
(A) Depol. CEE95 - Type/Typ: X1-X7 - TSN: 273
λ¹=Depol. EURO95/EUR096
λ²=Depol. 15-04

Ci65012 **CAT**

1705-KO 9220117CAT MK 21672	96106856 613133 MK 85407	1726 H6 613189 MK 85209
-----------------------------------	--------------------------------	-------------------------------

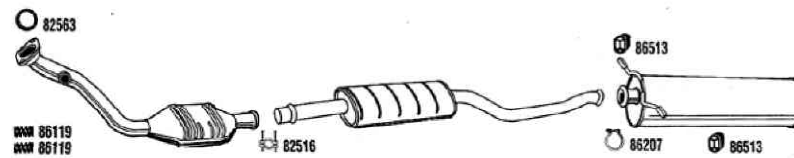

82563
82516
86513
86513
86207
86513

87854 87912

7319005

Xantia
2.0i 8v
06/95-01
1998 cc - 121 HP - 89 kW
Mot/Eng: XU10J2C
Type/Typ: X1-X2
TSN: 277-234-627-691

Ci65024 **CAT**

1731-43 9220474CAT(A) MK 21677	1717 56 613473	1726 H6 613189 MK 85209
--------------------------------------	-------------------	-------------------------------

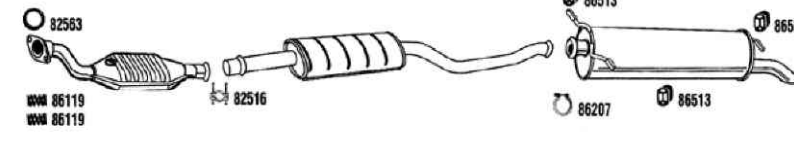

82563
82516
86513
86513
86207
86513

87854 87912 87854 87919

7319005

Xantia
2.0i 16v
06/95-01
1998 cc - 133 HP - 98 kW
Mot/Eng: XU10J4R
(A) Depol. CEE95 - Type/Typ: X1-X2
λ¹=Depol. EURO95/EUR096
λ²=Depol. 15-04

Ci65013 **CAT**

Los nombres y números de primer equipo se utilizan solamente como referencia

● En desarrollo

IMPORTANTE:

Al pedir sistemas de escape, rogamos completen la referencia comenzando por 'MFO.' (ejemplo: 381394 → MFO.381394)
 Pour commander echappement, nous vous prions de compléter la référence en commençant par MFO..
 When ordering exhaust, please complete the reference by beginning with MFO..

ESCAPE / ECHAPPEMENT / EXHAUST

Fonos

MOTOR / MOTEUR / ENGINE

Citroën

Xantia
Hatchback - 
 2.0i Turbo
06/95-10/96
 1998 cc - 147 HP - 108 kW
 Mot/Eng: XU10J2TE
 (A) = Hatchback - (B) = 
 Type/Typ: X1
 TSN: 274



1731-49
N.D.
 1717-60
613216
 MK 85407
 1726-J1
613217(A)
 MK 85209



N.D.(B)
 1726 J2

CI55018

A1 87854 87912

Xantia
Hatchback - 
 2.0i Turbo
06/95-01
 1998 cc - 147 HP - 108 kW
 Mot/Eng: XU10J2TE
 (A) = Hatchback - (B) = 
 Type/Typ: X1
 TSN: 274

1731-48
9220753CAT
 1717-60
613216
 MK 85407
 1726-J1
613217(A)
 MK 85209

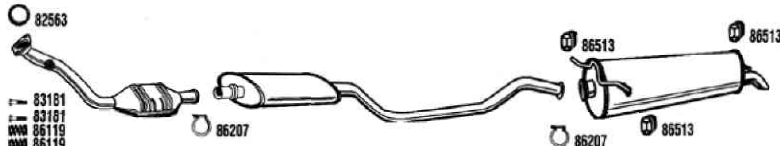

N.D.(B)
 1726 J2



7319005

CI55005 **CAT**

A1 87854 87912

Xantia
Hatchback
 1.9 Diesel
05/93-10/96
 1905 cc - 69 HP - 51 kW
 Mot/Eng: XUD9
 (A) = Hatchback - (B) = 
 Type/Typ: X1
 TSN: 259

1721-28
613509
 1705-57
613126
 MK 85590
 1726-81
613131
 MK 85142

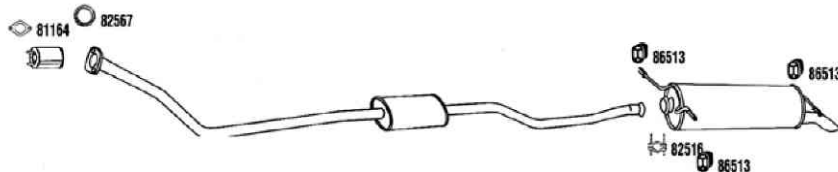

7319007

CI65005

Xantia
D-X-SX
 1.9 Diesel
03/93-10/96
 1905 cc - 69 HP - 51 kW
 Mot/Eng: XUD9A
 Type/Typ: X1 Serie 6A/3L
 Emission: CEE 95-L3 - US 87
 TSN: 258

1721-28
613509
 1705-E8
N.D.CAT
 1726-81
613131
 MK 85142

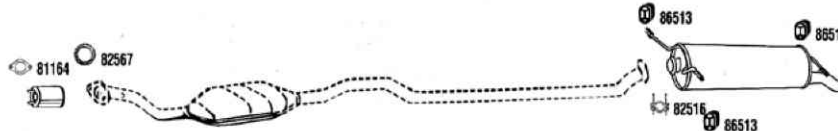

7319007

CI65014 **CAT**

Xantia
SD Hatchback
 1.9
11/96-12/00
 1905 cc - 75 HP - 55 kW
 Mot/Eng: XUD9SD
 Type/Typ: X1

1705-N8
9820468CAT
 1726-H4
613218
 MK 85209



7319006

CI65031 **CAT**

Xantia
D-X-SX-VSX
 1.9 TD
07/93-97
 1905 cc - 92 HP - 68 kW
 Mot/Eng: XUD9TF/TE
 Type/Typ: X1 Serie 8A
 TSN: 237-603

1705-58
313136
 1726-J0
613137
 MK 85209

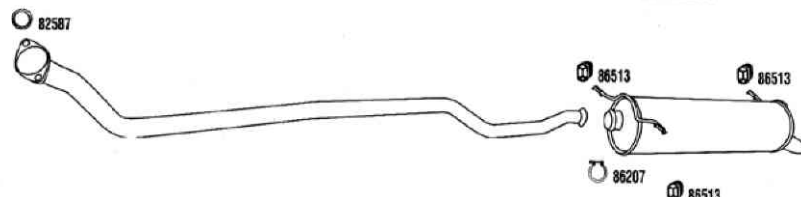

7319006









CI65006

● En desarrollo

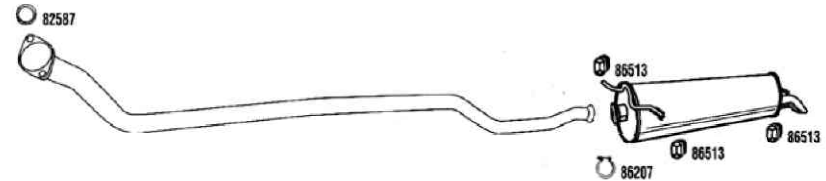
Los nombres y números de primer equipo se utilizan solamente como referencia

IMPORTANTE:

Al pedir sistemas de escape, rogamos completen la referencia comenzando por 'MFO.' (ejemplo: 381394 → MFO.381394)
 Pour commander echappement, nous vous prions de compléter la référence en commençant par MFO..
 When ordering exhaust, please complete the reference by beginning with MFO..

<p>1705 C2 9820217CAT</p> <p>1726-J0 613137 MK 85209</p>  <p>82587 AW 82520 AW 82520</p> <p>86513 86513 86207 86513</p> <p>7319006</p>	<p>Xantia D-X-SX-VSX 1.9 TD 05/93-12/00 1905 cc - 92 HP - 68 kW Mot/Eng: XUD9TF/TE-XUD9BTF Type/Typ: X1 Serie 8A TSN: 237, 603</p> <p>CAT</p>
<p>1705 N8 9820468CAT</p> <p>1726 W6 613219 MK 85209</p>  <p>82563 AW 86119 AW 86119</p> <p>86513 86513 86513 86513 82516</p> <p>7319006</p>	<p>Xantia SD  1.9 11/96-12/00 1905 cc - 75 HP - 55 kW Mot/Eng: XUD9SD Type/Typ: X1-X2</p> <p>CAT</p>
<p>1705-58 313136</p> <p>1726-H7 613213 MK 85209</p>  <p>82587</p> <p>86513 86513 86207 86513 86513</p> <p>7319006</p>	<p>Xantia X - SX - VSX  1.9 TD 03/95-06/97 1905 cc - 92 HP - 68 kW Mot/Eng: XUD9TE Type/Typ: X17F</p> <p>CAT</p>
<p>1705 C2 9820217CAT</p> <p>1726-H7 613213 MK 85209</p>  <p>82587 AW 82520 AW 82520</p> <p>86513 86513 86207 86513 86513</p> <p>7319006</p>	<p>Xantia X - SX - VSX   1.9 TD 09/95-12/00 1905 cc - 90 HP - 66 kW Mot/Eng: XUD9TE-XUD9BTF Type/Typ: X2 TSN: 280</p> <p>CAT</p>
<p>1705 C2 9820217CAT(A)</p> <p>1726-J0 613137 MK 85209</p>  <p>82587 AW 82520 AW 82520</p> <p>86513 86513 86207 86513 86513</p> <p>N.D.CAT(B) 1705 LF</p> <p>7319006</p>	<p>Xantia Hatchback 2.0 HDi 06/99- 1997 cc - 90 HP - 66 kW Mot/Eng: DW10TD (A) Depol. CEE95 (B) Depol. CEE2000 Type/Typ: X1</p> <p>CAT</p>
<p>1731 47 9220459CAT</p> <p>1717-59 613215</p> <p>1726-J0 613137 MK 85209</p>  <p>82563 AW 86119 AW 86119</p> <p>86219 86207 86513 86513 86513</p> <p>7319006</p>	<p>Xantia Hatchback 2.0 HDi 07/98-11/99 1997 cc - 109 HP - 80 kW Mot/Eng: DW10ATED Depol. CEE 95 Type/Typ: X1 TSN: 726</p> <p>CAT</p>

Los nombres y números de primer equipo se utilizan solamente como referencia

● En desarrollo

IMPORTANTE:

Al pedir sistemas de escape, rogamos completen la referencia comenzando por 'MFO.' (ejemplo: 381394 → MFO.381394)

Pour commander echappement, nous vous prions de compléter la référence en commençant par MFO..

When ordering exhaust, please complete the reference by beginning with MFO..

ESCAPE / ECHAPPEMENT / EXHAUST

Citroën

Fonos

Xantia
Hatchback
2.0 HDi
11/99-01
1997 cc - 109 HP - 80 kW
Mot/Eng: DW10ATED
Depol. CEE 95
Type/Typ: X1
TSN: 726

1705 GX
9720458CAT
MK 18473

1726-J0
613137
MK 85209

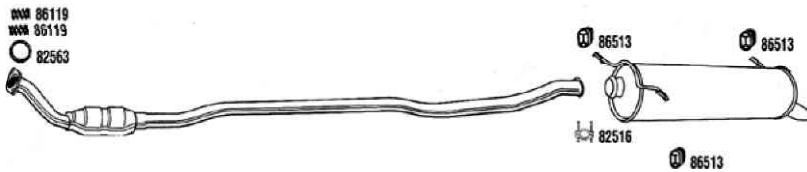

CI55020 **CAT**

Xantia
Hatchback
2.0 HDi
07/98-01
1997 cc - 109 HP - 80 kW
Mot/Eng: DW10ATED
Depol. CEE2000
(A) -11/99 - (B) 11/99-
Type/Typ: X1
TSN: 726

1731 J7
N.D.CAT(A)

1717 G6
613544(A)
MK 85407

1726-J0
613137
MK 85209

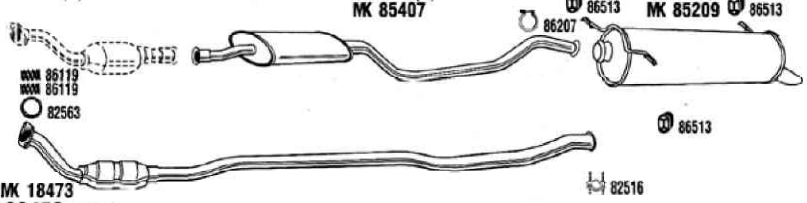

CI55019 **CAT**

Xantia
2.0 HDi
06/99-
1997 cc - 90 HP - 66 kW
Mot/Eng: DW10TD
(A) Depol. CEE95 (B) Depol. CEE2000
Type/Typ: X2

1705 C2
9820217CAT(A)

1726-H7
613213
MK 85209

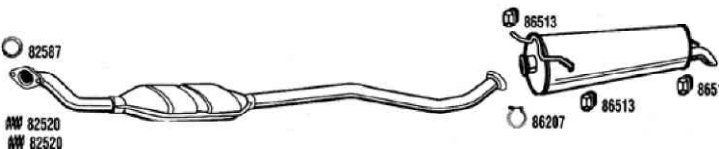

CI65034 **CAT**

Xantia
2.0 HDi
07/98-11/99
1997 cc - 109 HP - 80 kW
Mot/Eng: DW10ATED
Type/Typ: X2
TSN: 717
Emission:(A) Depol. CEE95
Emission:(B) Depol. CEE2000

1731 47
9220459CAT(A)

1717-59
613215(A)

1726-H7
613213
MK 85209



CI55014 **CAT**

Xantia
2.0 HDi
11/99-01
1997 cc - 109 HP - 80 kW
Mot/Eng: DW10ATED
Type/Typ: X2
TSN: 717

1705 GX
9720458CAT
MK 18473

1726-H7
613213
MK 85209

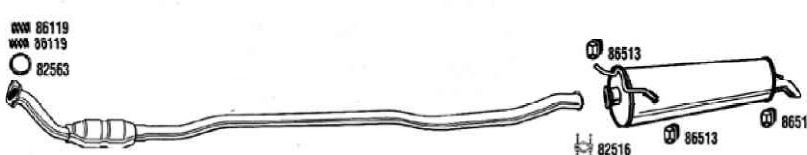

CI55021 **CAT**

Xantia
Hatchback
2.1 TD
06/95-01
2088 cc - 109 HP - 80 kW
Mot/Eng: XUD11BTE
(A) -09/98 - (B) -09/98-
Type/Typ: X1-X7
TSN: 275

1731 47
9220459CAT

1717-59
613215(A)

1726-J0
613137
MK 85209

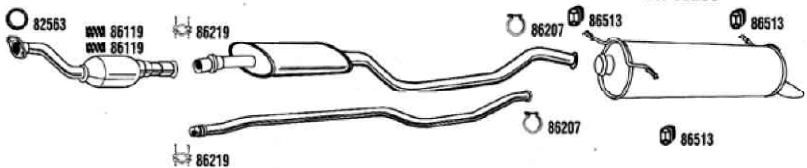

CI55007 **CAT**

6603472(B)
1717 E7

7319006

● En desarrollo

Los nombres y números de primer equipo se utilizan solamente como referencia

IMPORTANTE:

Al pedir sistemas de escape, rogamos completen la referencia comenzando por 'MFO.' (ejemplo: 381394 → MFO.381394)

Pour commander echappement, nous vous prions de compléter la référence en commençant par MFO..

When ordering exhaust, please complete the reference by beginning with MFO..

1731-46 N.D.CAT	1717-59 613215	1726-J0 613137 MK 85209
--------------------	-------------------	-------------------------------

7319006

Xantia
Hatchback
2.1 TD
06/95-10/96
2088 cc - 109 HP - 80 kW
Mot/Eng: XUD11BTE
only Ireland
Type/Typ: X1

Ci55011 **CAT**

1731 47 9220459CAT	1717-59 613215(A)	1726-H7 613213 MK 85209
-----------------------	----------------------	-------------------------------

6603472(B)
1717 E7

7319006

Xantia
2.1 TD
06/95-01
2088 cc - 109 HP - 80 kW
Mot/Eng: XUD11BTE
(A)=-09/98
(B)=09/98-
Type/Typ: X2

Ci55015 **CAT**

96021645 613106(A)	96021664 613107	96131133 613108 MK 85170
-----------------------	--------------------	--------------------------------

7315434

XM
2.0
05/89-06/92
1998 cc - 115 HP - 85 kW
Mot/Eng: R2A
(A) Autom.
Type/Typ: Y3 serie AA/AB

Ci78001

96021645 613106	96021664 613107	96131133 613108 MK 85170
--------------------	--------------------	--------------------------------

7315434

XM
Confort-Ambiance
2.0i
05/89-06/92
1998 cc - 130 HP - 96 kW
Mot/Eng: R6A
Type/Typ: Y3 serie AC/AJ

Ci78002

1704-84 9220387CAT MK 18473	96045753 613556	96021664 613107	96131133 613108 MK 85170
-----------------------------------	--------------------	--------------------	--------------------------------

λ1 87854 87910 87999x2

7317557

XM
Presence-Ambiance
2.0i
09/89-06/94
1998 cc - 121 HP - 89 kW
Mot/Eng: XU10MJ2/Z
Type/Typ: Y3 Serie AH/AP/AR
TSN: 484

Ci78012 **CAT**

1705 A1 9220386CAT MK 18473	1717-47 613196	96119136 613198	1726-F3 613195
-----------------------------------	-------------------	--------------------	-------------------

λ1 87854 87910 87999x2 λ2 87854 87912 87999

7319314

XM
SX - VSX
2.0i 16v Autom.
07/94-07/00
1998 cc - 135 HP - 99 kW
Mot/Eng: XU10J4R
Type/Typ: Y4TX Y4CZ - TSN: 246
λ1=07/94->04/96
λ2=05/96->07/00

Ci78016 **CAT**

Los nombres y números de primer equipo se utilizan solamente como referencia

● En desarrollo

IMPORTANTE:

Al pedir sistemas de escape, rogamos completen la referencia comenzando por 'MFO.' (ejemplo: 381394 → MFO.381394)
Pour commander echappement, nous vous prions de compléter la référence en commençant par MFO..
When ordering exhaust, please complete the reference by beginning with MFO..

ESCAPE / ECHAPPEMENT / EXHAUST

Fonos

Citroën

XM
SX - VSX
2.0i 16v Autom.
07/94-07/00
1998 cc - 135 HP - 99 kW
Mot/Eng: XU10J4R
(A)= DEPOL. CEE 19-5 PSA K071
(B)= DEPOL. CEE 95-L3 PSA K075
Type/Typ: Y4TV - TSN: 246
λ¹=07/94->04/96
λ²=05/96->07/00
CI78017 **CAT**

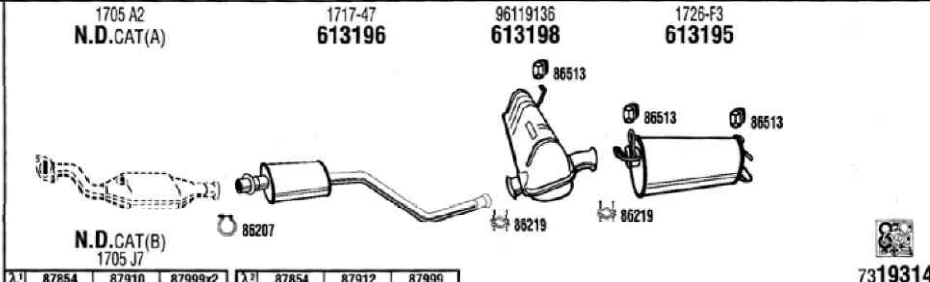

XM
2.0i 16v Turbo
08/94-07/99
1998 cc - 150 HP - 110 kW
Mot/Eng: XU10J2TE
(A)= DEPOL. US 83
(B)= DEPOL. CEE 95
Type/Typ: Y4
CI78042 **CAT**

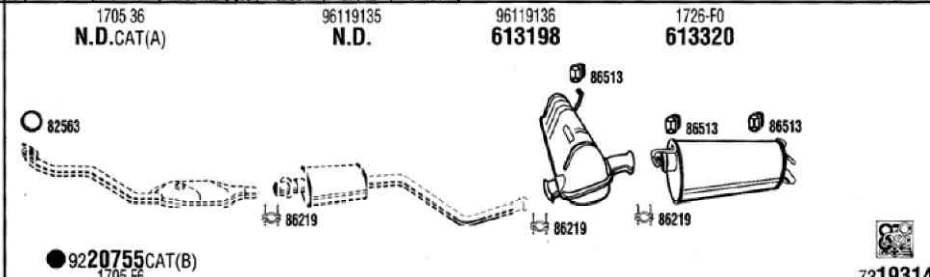

XM
Détente-Ambiance
2.0i
11/89-09/94
1998 cc - 121 HP - 89 kW
Mot/Eng: XU10J2Z
Type/Typ: Y3 Serie AP/AR
TSN: 211
λ¹=05/91->09/94
CI78014 **CAT**

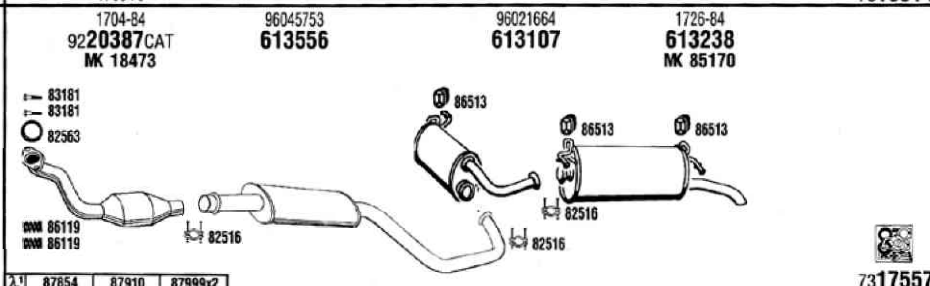

XM
Ambiance-Détente
2.0i
10/91-06/92
1998 cc - 130 HP - 96 kW
Mot/Eng: R6A
Type/Typ: Y3 serie AP/AR
CI78008

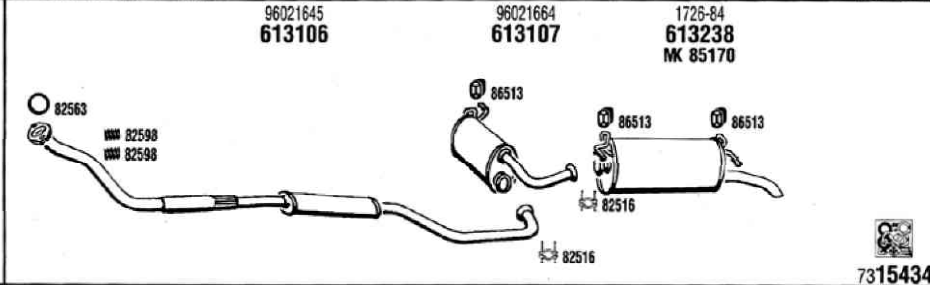

XM

2.0
10/91-06/92
1998 cc - 115 HP - 85 kW
Mot/Eng: R2A
Type/Typ: Y3 serie AC
CI78007

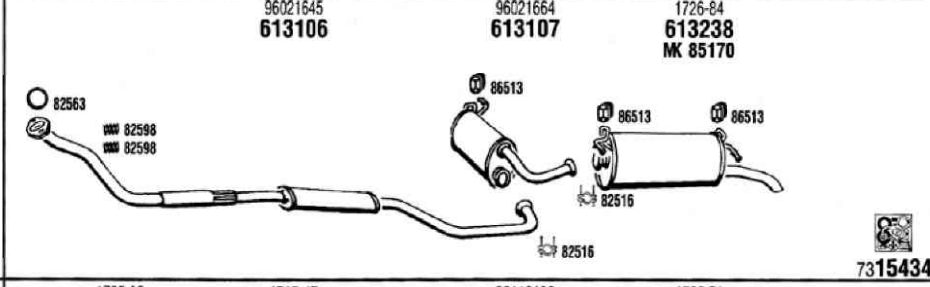

XM
SX - VSX
2.0i 16v
07/94-07/00
1998 cc - 135 HP - 99 kW
Mot/Eng: XU10J4R
(A)= DEPOL. CEE 19-5 PSA K071
(B)= DEPOL. CEE 95-L3 PSA K075
Type/Typ: Y44B-Y4TU - TSN: 247
λ¹=07/94->04/96
λ²=05/96->07/00
CI78030 **CAT**

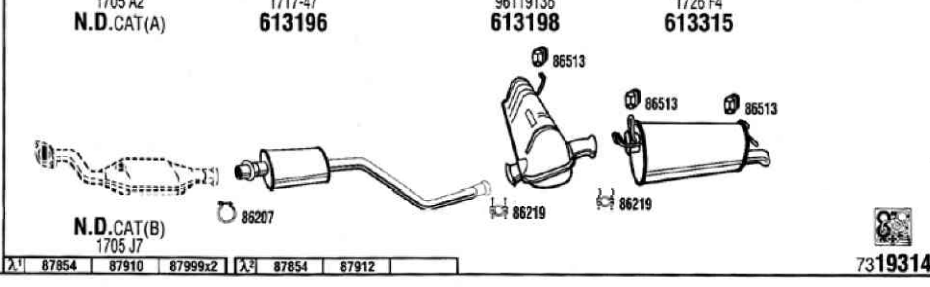

● En desarrollo

Los nombres y números de primer equipo se utilizan solamente como referencia

IMPORTANTE:

Al pedir sistemas de escape, rogamos completen la referencia comenzando por 'MFO.' (ejemplo: 381394 → MFO.381394)
Pour commander echappement, nous vous prions de compléter la référence en commençant par MFO..
When ordering exhaust, please complete the reference by beginning with MFO..

Fonov

1705 36 N.D.CAT(A)	96119135 N.D.	96119136 613198	96 119 138 N.D.
-----------------------	------------------	--------------------	--------------------

● 9220755CAT(B)
1705 FB

87854	87912	87999
-------	-------	-------

7319314

XM
 2.0i 16v Turbo
08/94-07/99
 1998 cc - 150 HP - 110 kW
 Mot/Eng: XU10J2TE
 (A) = DEPOL US 83 - (B) = DEPOL. CEE 95
 Type/Typ: Y4

CI78043 **CAT**

96090538 N.D.	96030333 N.D.CAT	94560389 815420	95654014 613421	95666769 613422(A) MK 85067
------------------	---------------------	--------------------	--------------------	-----------------------------------

87854	87910	87999x2	87854	87912	87999
-------	-------	---------	-------	-------	-------

7315423

XM
V SX-Pallas
 3.0i V6 12v
05/89-12/98
 2975 cc - 167 HP - 123 kW
 Mot/Eng: SFZ-ZPJ2
 (A) = (B)
 Type/Typ: Y3 serie AG-AW
 TSN: 485-250-212-251
 λ1=10/91->00/94
 λ2=00/94->12/98

CI78035 **CAT**

96084196 N.D.	1731-32 N.D.CAT	95654018 6617120	95666769 613422 MK 85067
------------------	--------------------	---------------------	--------------------------------

87854	87910	87999x2	87854	87912	87999
-------	-------	---------	-------	-------	-------

7317121

XM
Pallas-Exclusive
 3.0i V6 24v
10/91-06/96
 2975 cc - 200 HP - 147 kW
 Mot/Eng: SKZ-ZPJ4
 Type/Typ: Y3 serie AL-Y4
 TSN: 492-252
 λ1=10/91->00/94
 λ2=00/94->06/96

CI78006 **CAT**

96021651 613122	96021664 613107	96131133 613108 MK 85170
--------------------	--------------------	--------------------------------

7315434

XM
Presence-Sensation
 2.1 12v Diesel
05/89-08/96
 2138 cc - 83 HP - 61 kW
 Mot/Eng: P9A-XUD11A/L
 Type/Typ: Y3 serie AE/GV-Y4
 TSN: 490

CI78003

96126945 N.D.	95666770 613123	95654020 613425	95666771 613199(A) MK 85067
------------------	--------------------	--------------------	-----------------------------------

7315434

XM
SX-Détente
 2.1 12v Diesel
10/91-08/96
 2138 cc - 83 HP - 61 kW
 Mot/Eng: P9A-XUD11A/L
 Type/Typ: Y3 serie AS/GW-Y4

CI78010

96126945 N.D.	95666770 613123	95654020 613425	95666771 613199(A) MK 85067
------------------	--------------------	--------------------	-----------------------------------

7315426

XM
SX-V SX-Détente-Ambiance
 Hatchback -
 2.1 TD 12v
09/89-09/96
 2088 cc - 109 HP - 80 kW
 Mot/Eng: P8A-XUD11ATE/L
 (A) = (B) Hatchback
 Type/Typ: Y3 Serie AT/GY/NW
 TSN: 213-253-254-491

CI78011

Los nombres y números de primer equipo se utilizan solamente como referencia

● En desarrollo



IMPORTANTE:

Al pedir sistemas de escape, rogamos completen la referencia comenzando por 'MFO.' (ejemplo: 381394 → MFO.381394)
 Pour commander echappement, nous vous prions de compléter la référence en commençant par MFO..
 When ordering exhaust, please complete the reference by beginning with MFO..

ESCAPE / ECHAPPEMENT / EXHAUST

Citroën

Fonos

XM
Hatchback - 
2.1 TD
07/94-07/00
2088 cc - 109 HP - 81 kW
Mot/Eng: XUD118TE
(A) Hatchback - (B) 
(C) DEPOL. CEE 95-L3
(D) DEPOL. CEE 2000
Type/Typ: Y4WL-Y4WD-Y4NW
TSN: 253-254
CI178034 **CAT**

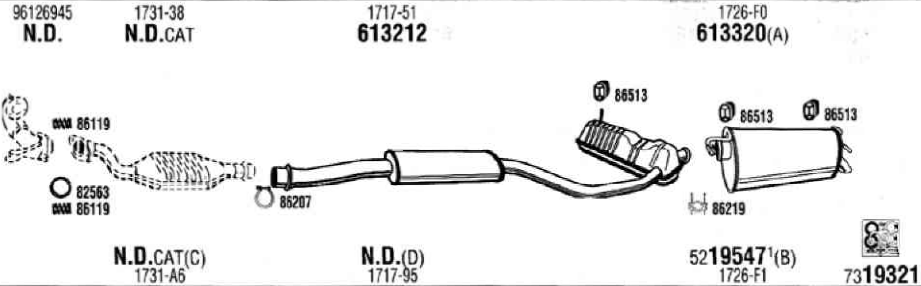

XM
Hatchback
2.5 TD
08/94-08/00
2446 cc - 131 HP - 96 kW
Mot/Eng: DK5ATE
Type/Typ: Y4
CI178038

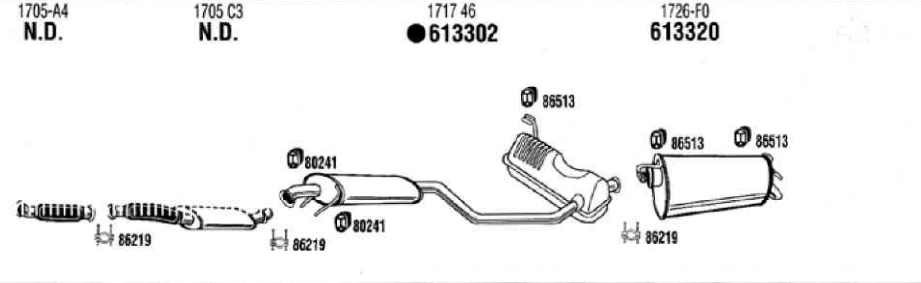

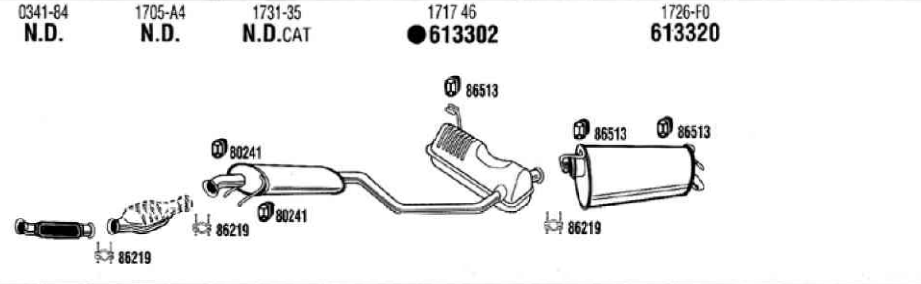

XM
Hatchback
2.5 TD
08/94-08/00
2446 cc - 131 HP - 96 kW
Mot/Eng: DK5ATE
Type/Typ: Y4
CI178036 **CAT**



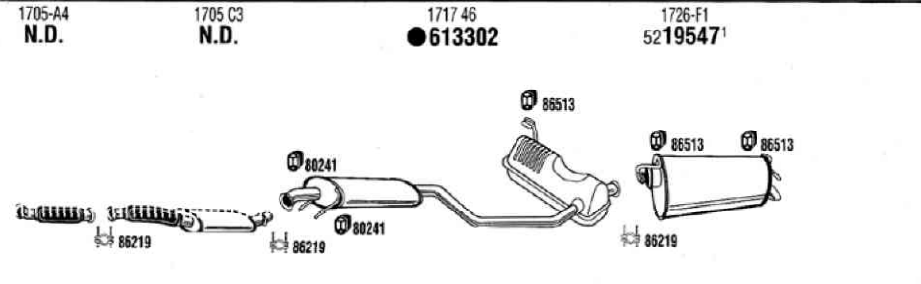

XM

2.5 TD
08/94-08/00
2446 cc - 131 HP - 96 kW
Mot/Eng: DK5ATE
Type/Typ: Y4
CI178039

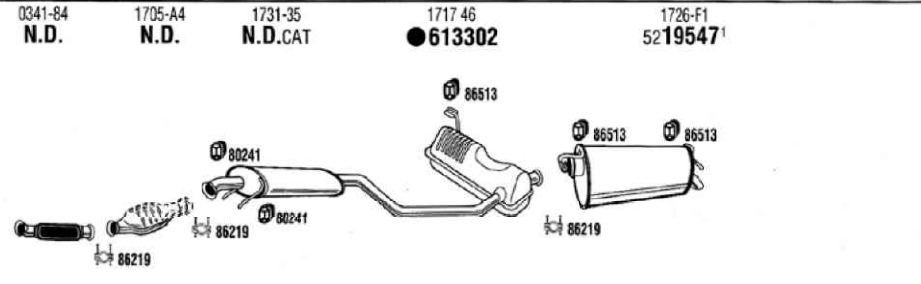

XM

2.5 TD
08/94-08/00
2446 cc - 131 HP - 96 kW
Mot/Eng: DK5ATE
Type/Typ: Y4
CI178037 **CAT**

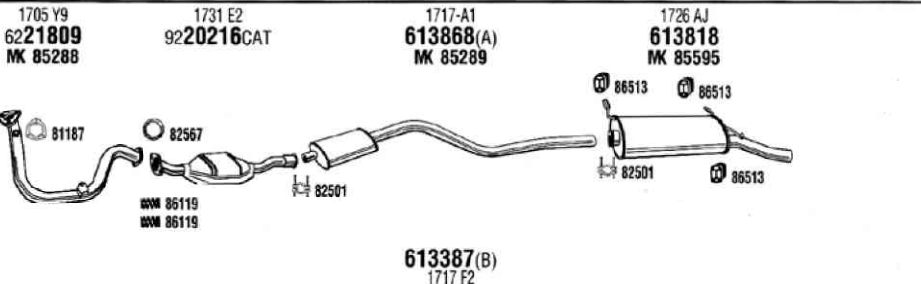

Xsara
Hatchback -  (3) 
1.4i
07/97-08/00
1360 cc - 75 HP - 55 kW
Mot/Eng: TU3JP (KFX)
DEPOL. CEE 2000
(A) = up to -02/99 (Code 0.08147)
(B) = from 03/99- (Code 0.06148)
Type/Typ: N1-N3 - TSN: 641
CI116025 **CAT**



● En desarrollo

Los nombres y números de primer equipo se utilizan solamente como referencia

IMPORTANTE:

Al pedir sistemas de escape, rogamos completen la referencia comenzando por 'MFO.' (ejemplo: 381394 → MFO.381394)
Pour commander echappement, nous vous prions de compléter la référence en commençant par MFO..
When ordering exhaust, please complete the reference by beginning with MFO..

MOTOR / MOTEUR / ENGINE

Fonos

Citroën

1705 Y9 6221809 MK 85288	1731 E2 9220216CAT	1717-A1 613868(A) MK 85289	1726 GA 613821 MK 85142 86513 86513 82501 86513
---------------------------------------	-----------------------	---	--

613387(B)
1717 F2

Xsara
1.4i
05/98-08/00
1360 cc - 75 HP - 55 kW
Mot/Eng: TU3JP (KFX)
DEPOL. CEE 2000
(A) = 02/09 (Code 0.8147)
(B) = 03/99- (Code 0.8148-)
Type/Typ: N2 - TSN: 679
CI16036 **CAT**

1705 V8 6221808 MK 85288 81187	1731 88 9220242CAT MK 87173	1717-C9 613867 MK 85290	1726 AJ 613818(A) MK 85595 86513 86513 82501 86513
--	-----------------------------------	--------------------------------------	---

613821(B)
1726 GA

Xsara
Hatchback -
1.4i
07/97-08/00
1360 cc - 75 HP - 55 kW
Mot/Eng: TU3JP (DEPOL.15-04 & CEE 95)
up to -02/99 (Code 0.8147)
(A) Hatchback (B)
Type/Typ: N0-N1-N2-N3 - TSN: 641-679
λ¹=07/97->12/97
λ²=01/98->08/00
CI16047 **CAT**

λ ¹ 87853 87905 87998	λ ² 87854 87912	1705 V8 6221808 MK 85288 81187	1731 95 9220255CAT MK 87173	1717 F2 613387	1726 AJ 613818(A) MK 85595 86513 86513 82501 86513
----------------------------------	----------------------------	--	-----------------------------------	--------------------------	---

613821(B)
1726 GA

Xsara
Hatchback -
1.4i
07/97-08/00
1360 cc - 75 HP - 55 kW
Mot/Eng: TU3JP (DEPOL.15-04 & CEE 95)
from 03/99- (Code 0.8148)
(A) Hatchback (B)
Type/Typ: N1-N2-N3 - TSN: 641-679
λ¹=07/97->12/97
λ²=01/98->08/00
CI16048 **CAT**

λ ¹ 87853 87905 87998	λ ² 87854 87912	1731 P7 N.D.CAT	1717 N7 613403(A)	1726 JJ 613427 MK 85932 80285 80285 86019 80285
----------------------------------	----------------------------	--------------------	-----------------------------	--

Xsara
Hatchback -
1.4
09/00-
1360 cc - 75 HP - 55 kW
Mot/Eng: TU3JP
(A) Autom.
Type/Typ: N1K
CI16076 **CAT**

1731 P7 N.D.CAT	1717 N7 613403(A)	1726 JK 613221 MK 85932 80285 86515 86019 80285
--------------------	-----------------------------	--

Xsara

1.4
09/00-
1360 cc - 75 HP - 55 kW
Mot/Eng: TU3JP
(A) Autom.
Type/Typ: N2K
CI16077 **CAT**

1731 P7 N.D.CAT	1717 N7 613403(A)	1726 JJ 613427 MK 85932 80285 80285 86019 80285
--------------------	-----------------------------	--

Xsara
Coupé
1.4
09/00-
1360 cc - 75 HP - 55 kW
Mot/Eng: TU3JP
(A) Autom.
Type/Typ: N0K
CI16078 **CAT**

Los nombres y números de primer equipo se utilizan solamente como referencia

● En desarrollo

IMPORTANTE:

Al pedir sistemas de escape, rogamos completen la referencia comenzando por 'MFO.' (ejemplo: 381394 → MFO.381394)
Pour commander echappement, nous vous prions de compléter la référence en commençant par MFO..
When ordering exhaust, please complete the reference by beginning with MFO..

ESCAPE / ECHAPPEMENT / EXHAUST

Citroën

Fonos

Xsara
Hatchback - Coupé

1.6i
07/97-08/00
1587 cc - 90 HP - 66 kW
Mot/Eng: TU5JP
-02/99 (Code -0.8147)
(A) = Autom. (B) = Autom.
Type/Typ: N0 - N1

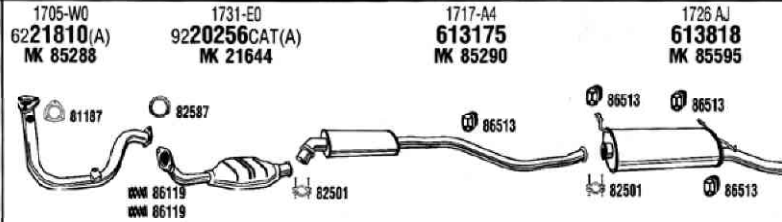

CI16001 **CAT**

N.D.CAT(B) 1705 FF 9220336CAT(B) 1731 H7

Xsara
Hatchback - Coupé

1.6i
07/97-08/00
1587 cc - 90 HP - 66 kW
Mot/Eng: TU5JP
03/99- (Code 0.8148-)
(A) = Autom. (B) = Autom. - Type/Typ: N0-N1
λ¹-Depot. EURO95/EURO96
λ²-07/97->01/98 Depot. 15-04
λ³-02/98->08/00 Depot. 15-04

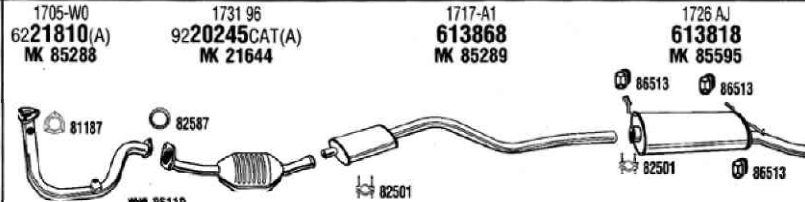

CI16021 **CAT**

N.D.CAT(B) 1705 FF 9220336CAT(B) 1731 H7

Xsara

1.6i
05/98-08/00
1587 cc - 90 HP - 66 kW
Mot/Eng: TU5JP
-02/99 (Code 0.8148-) - (A) = Autom. (B) = Autom.
Type/Typ: N2 - TSN: 680
λ¹-Depot. EURO95/EURO96
λ²-Depot. 15-04

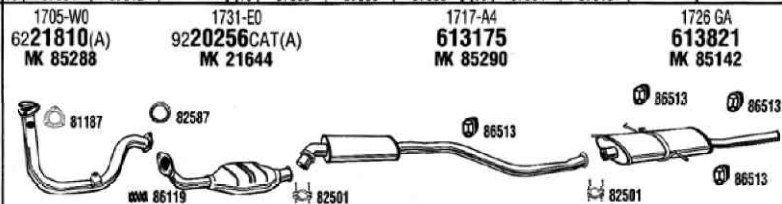

CI16013 **CAT**

N.D.CAT(B) 1705 FF 9220336CAT(B) 1731 H7

Xsara

1.6i
05/98-08/00
1587 cc - 90 HP - 66 kW
Mot/Eng: TU5JP
03/99- (Code 0.8148-)
(A) = Autom. (B) = Autom.
Type/Typ: N2 - TSN: 680
λ¹-Depot. EURO95/EURO96
λ²-Depot. 15-04

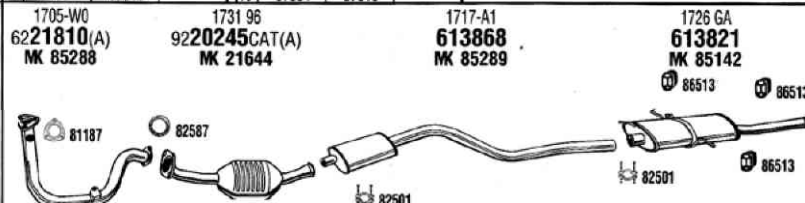

CI16014 **CAT**

N.D.CAT(B) 1705 FF 9220336CAT(B) 1731 H7

Xsara
Hatchback

1.6
09/00-
1587 cc - 109 HP - 80 kW
Mot/Eng: TU5JP4
(A) Autom. - (B) Autom.
Type/Typ: N1N

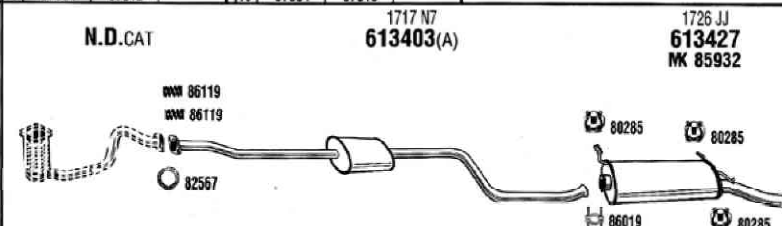

CI16073 **CAT**

613754(B) 1717K4

Xsara

1.6
09/00-
1587 cc - 109 HP - 80 kW
Mot/Eng: TU5JP4
(A) Autom. - (B) Autom.
Type/Typ: N2N

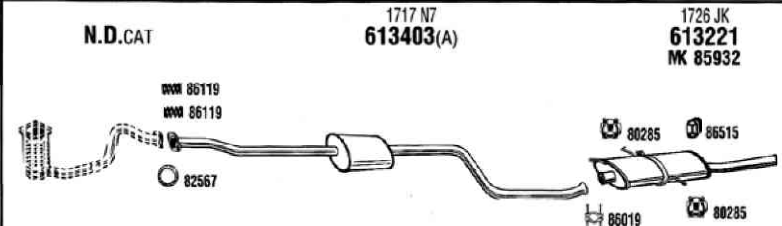

CI16074 **CAT**

613754(B) 1717K4

● En desarrollo

Los nombres y números de primer equipo se utilizan solamente como referencia

IMPORTANTE:

Al pedir sistemas de escape, rogamos completen la referencia comenzando por 'MFO.' (ejemplo: 381394 → MFO.381394)
Pour commander echappement, nous vous prions de compléter la référence en commençant par MFO..
When ordering exhaust, please complete the reference by beginning with MFO..

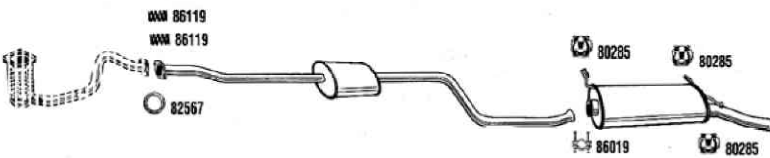
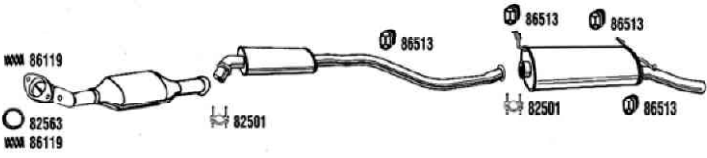
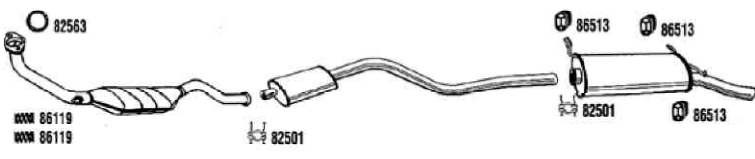
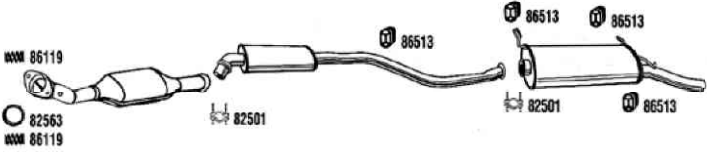
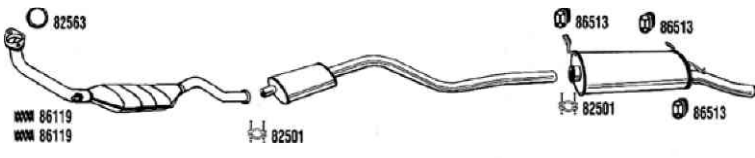
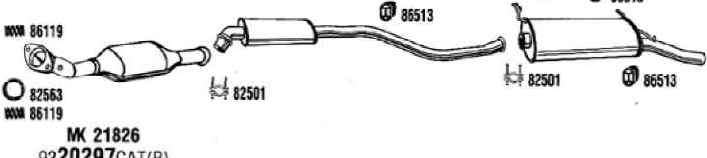
<p>N.D.CAT</p>  <p>1717 N7 613403(A)</p> <p>1726 JJ 613427 MK 85932</p> <p>86119, 86119, 82567, 80285, 86019, 80285</p>	<p>613754(B) 1717K4</p>	<p>Xsara Coupé 1.6 05/01- 1587 cc - 109 HP - 80 kW Mot/Eng: TU5JP4 (A) Autom. - (B) Autom. Type/Typ: NON</p> <p>CI16075 CAT</p>
<p>1705-Y8 9219790CAT MK 19278</p>  <p>86119, 82563, 86119, 86513, 82501, 86513, 86513</p>	<p>1717-A4 613175 MK 85290</p> <p>1726 AJ 613818 MK 85595</p>	<p>Xsara Hatchback 1.8i Autom. 07/97-08/00 1761 cc - 90 HP - 66 kW Mot/Eng: XU7JB -02/99 (Code -0.8147) Type/Typ: N1 TSN: 643</p> <p>CI16002 CAT</p>
<p>1705 T8 9320297CAT MK 21826</p>  <p>82563, 86119, 86119, 82501, 86513, 86513</p>	<p>1717-A1 613868 MK 85289</p> <p>1726 AJ 613818 MK 85595</p>	<p>Xsara Hatchback 1.8i Autom. 07/97-08/00 1761 cc - 90 HP - 66 kW Mot/Eng: XU7JB 03/99- (Code 0.8148-) Type/Typ: N1 TSN: 643</p> <p>CI16035 CAT</p>
<p>1705-Y8 9219790CAT MK 19278</p>  <p>86119, 82563, 86119, 82501, 86513, 86513</p>	<p>1717-A4 613175 MK 85290</p> <p>1726 AJ 613818 MK 85595</p>	<p>Xsara Hatchback - Coupé 1.8i Autom. 07/97-08/00 1761 cc - 101 HP - 74 kW Mot/Eng: XU7JP -02/99 (Code -0.8147) Type/Typ: NO-N1 TSN: 644</p> <p>CI16003 CAT</p>
<p>1705 T8 9320297CAT MK 21826</p>  <p>82563, 86119, 86119, 82501, 86513, 86513</p>	<p>1717-A1 613868 MK 85289</p> <p>1726 AJ 613818 MK 85595</p>	<p>Xsara Hatchback - Coupé 1.8i Autom. 07/97-08/00 1761 cc - 101 HP - 74 kW Mot/Eng: XU7JP 03/99- (Code 0.8148-) Type/Typ: NO - N1 TSN: 644</p> <p>CI16034 CAT</p>
<p>1705-Y8 9219790CAT(A) MK 19278</p>  <p>86119, 82563, 86119, 82501, 86513, 86513, 86513</p> <p>MK 21826 9320297CAT(B) 1705 T8</p>	<p>1717-A4 613175 MK 85290</p> <p>1726 AJ 613818 MK 85595</p>	<p>Xsara Hatchback - Coupé 1.8i 16v 07/97-08/00 1761 cc - 111 HP - 82 kW Mot/Eng: XU7JP4 -02/99 (Code -0.08147) (A) Depol. CEE 95 (B) Depol. D3 Type/Typ: NO-N1 TSN: 645</p> <p>CI16004 CAT</p>

Los nombres y números de primer equipo se utilizan solamente como referencia

● En desarrollo

IMPORTANTE:

Al pedir sistemas de escape, rogamos completen la referencia comenzando por 'MFO.' (ejemplo: 381394 → MFO.381394)

Pour commander echappement, nous vous prions de compléter la référence en commençant par MFO..

When ordering exhaust, please complete the reference by beginning with MFO..

ESCAPE / ECHAPPEMENT / EXHAUST

Citroën

Fonos

Xsara
Hatchback - Coupé
 1.8i 16v
07/97-08/00
 1761 cc - 111 HP - 82 kW
 Mot/Eng: XU7JP4
 03/99- (Code 0.08147-)
 Depol. CEE 95 + Depol. D3
 Type/Typ: N0-N1
 TSN: 644-645



CI16012 **CAT**

Xsara

 1.8i 8v
05/98-08/00
 1761 cc - 90 (XU7JB), 101 (XU7JP) HP
 - 66 (XU7JB), 74 (XU7JP) kW
 Mot/Eng: XU7JB-XU7JP
 -02/99 (Code 0.8147)
 Type/Typ: N2 - TSN: 681

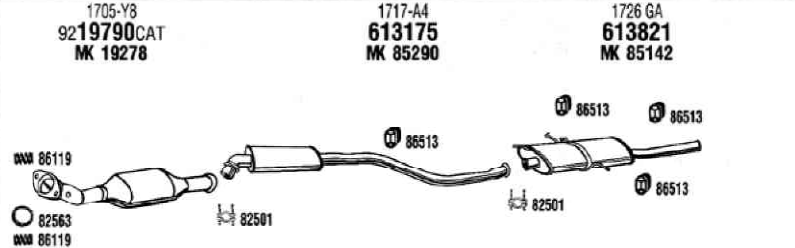

CI16008 **CAT**

Xsara

 1.8i Autom
05/98-08/00
 1761 cc - 90 (XU7JB), 101 (XU7JP) HP
 - 66 (XU7JB), 74 (XU7JP) kW
 Mot/Eng: XU7JB-XU7JP
 03/99- (Code 0.8148-)
 Type/Typ: N2 - TSN: 682

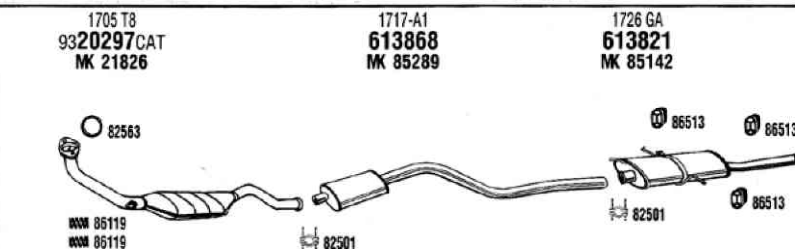

CI16031 **CAT**

Xsara

 1.8i 16v
05/98-08/00
 1761 cc - 111 HP - 82 kW
 Mot/Eng: XU7JP4
 -02/99 (Code 0.08147)
 (A) Depol. CEE 95 (B) Depol. D3
 Type/Typ: N2
 TSN: 682-683

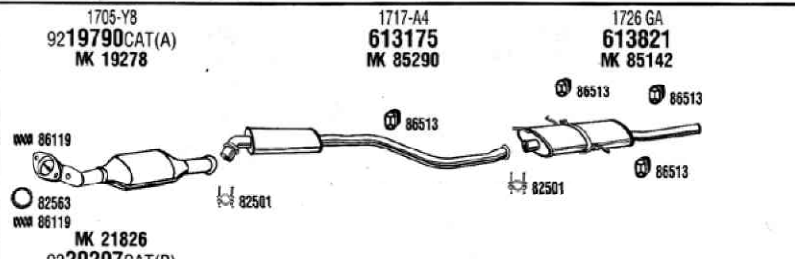

CI16010 **CAT**

Xsara

 1.8i 16v
05/98-08/00
 1761 cc - 111 HP - 82 kW
 Mot/Eng: XU7JP4
 03/99- (Code 0.08148-)
 Depol. CEE 95 + Depol. D3
 Type/Typ: N2
 TSN: 682-683

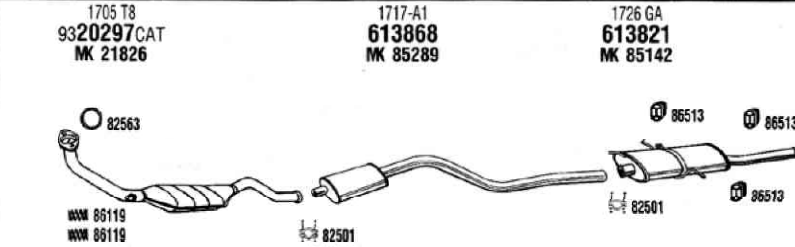

CI16011 **CAT**

Xsara
VTS Hatchback -
 2.0i 16v
01/98-08/00
 1998 cc - 133 HP - 98 kW
 Mot/Eng: XU10J4R
 (A) Hatchback (B) Wagon
 Type/Typ: N1- N2

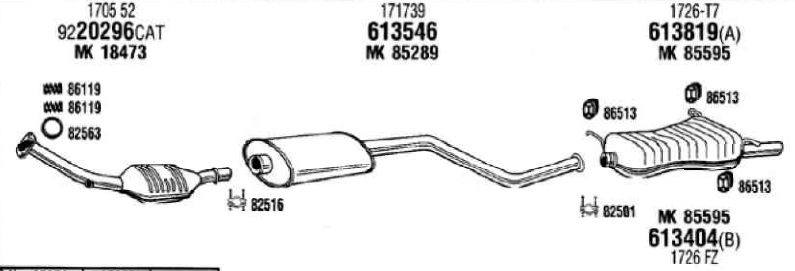

CI16023 **CAT**

● En desarrollo

Los nombres y números de primer equipo se utilizan solamente como referencia

IMPORTANTE:

Al pedir sistemas de escape, rogamos completen la referencia comenzando por 'MFO.' (ejemplo: 381394 → MFO.381394)
 Pour commander echappement, nous vous prions de compléter la référence en commençant par MFO..
 When ordering exhaust, please complete the reference by beginning with MFO..

1705 L9 920388CAT MK 21826	171739 613546 MK 85289	1726-T7 613819 MK 85595

Xsara
VTS Hatchback
2.0i 16v
01/98-08/00
1998 cc - 166 HP - 122 kW
Mot/Eng: XU10J4RS
Type/Typ: NORFSF

C116024 **CAT**

1705 JA N.D.CAT(A)	1705 NA N.D.CAT(B)	1717 K5 613399 MK 85289	1726-T7 613819 MK 85595

Xsara
Hatchback
2.0
09/00-
1997 cc - 136 HP - 100 kW
Mot/Eng: EW10J4 - Depol. L4 & Depol. IFL5
(A) 05/01
(B) 05/01-06/01
(C) 06/01-
Type/Typ: N1RFN1

C116061 **CAT**

1705 LG N.D.CAT(A)	1705 NC N.D.CAT(B)	1717 K5 613399 MK 85289	1726 AY N.D.

Xsara
Hatchback
2.0
09/00-
1997 cc - 136 HP - 100 kW
Mot/Eng: EW10J4 - Depol. US83
(A) 05/01
(B) 05/01-12/01
(C) 12/01-
Type/Typ: N1RFN1

C116062 **CAT**

1705 JA N.D.CAT(A)	1705 NA N.D.CAT(B)	1717 K5 613399 MK 85289	1726 FZ 613404 MK 85595

Xsara

2.0
09/00-
1997 cc - 136 HP - 100 kW
Mot/Eng: EW10J4 - Depol. L4 & Depol. IFL5
(A) 05/01
(B) 05/01-06/01
(C) 06/01-
Type/Typ: N2RFN1

C116067 **CAT**

1705 LG N.D.CAT(A)	1705 NL N.D.CAT(B)	1717 K5 613399 MK 85289	1726 FY N.D.

Xsara

2.0
09/00-
1997 cc - 136 HP - 100 kW
Mot/Eng: EW10J4 - Depol. US83
(A) 05/01
(B) 05/01-12/01
(C) 12/01-
Type/Typ: N2RFN1

C116068 **CAT**

1705 JC N.D.CAT	1717 K5 613399 MK 85289	1726-T7 613819 MK 85595

Xsara
Coupé VTS
2.0
09/00-
1997 cc - 166 HP - 122 kW
Mot/Eng: XU10J4RS
Type/Typ: NORFSB

C116069 **CAT**

Los nombres y números de primer equipo se utilizan solamente como referencia

● En desarrollo

IMPORTANTE:

Al pedir sistemas de escape, rogamos completen la referencia comenzando por 'MFO.' (ejemplo: 381394 → MFO.381394)
Pour commander echappement, nous vous prions de compléter la référence en commençant par MFO..
When ordering exhaust, please complete the reference by beginning with MFO..

ESCAPE / ECHAPPEMENT / EXHAUST

Fonos

Citroën

Xsara Coupé VTS
2.0 Autom.
09/00-

1997 cc - 136 HP - 100 kW
Mot/Eng: EW10J4 - Depol. L4 & Depol. IFL5
(A) -05/01
(B) 05/01-06/01
(C) 06/01-
Type/Typ: NORFN1

CI16063 **CAT**

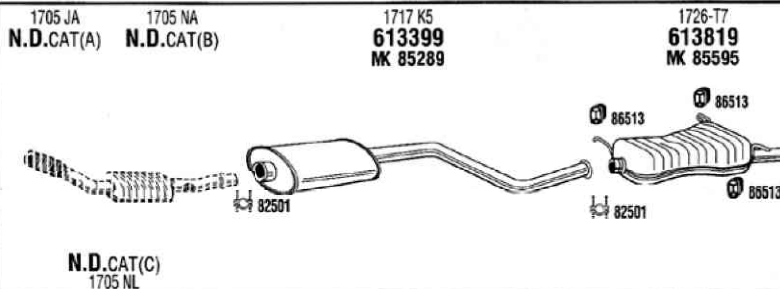

Xsara Coupé VTS
2.0 Autom.
09/00-

1997 cc - 136 HP - 100 kW
Mot/Eng: EW10J4 - Depol. US83
(A) -05/01
(B) 05/01-12/01
(C) 12/01-
Type/Typ: NORFN1

CI16064 **CAT**

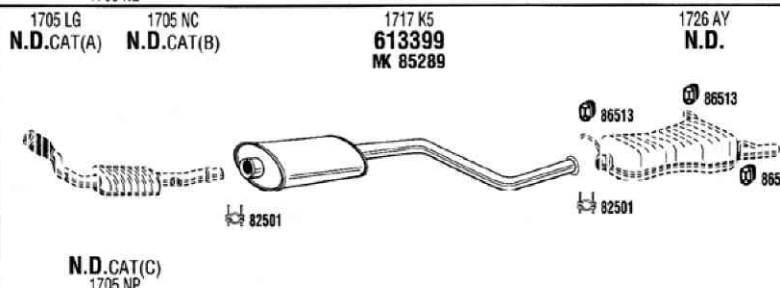

Xsara Coupé VTS
2.0 Autom.
05/01-

1997 cc - 136 HP - 100 kW
Mot/Eng: EW10J4 - Depol. L4 & Depol. IFL5
(A) -**/** (Code 0.09218)
(B) **/**- (Code 0.09219-)
Type/Typ: NORFN3

CI16065 **CAT**

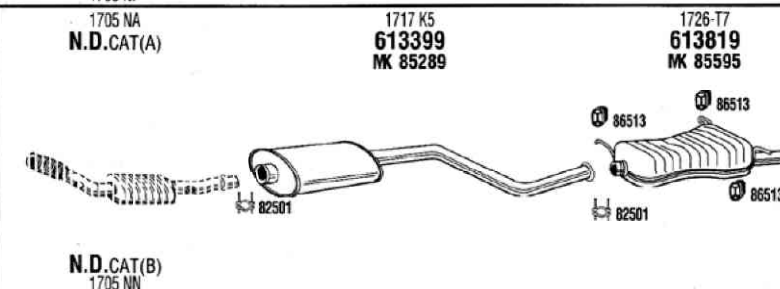

Xsara Coupé VTS
2.0 Autom.
05/01-

1997 cc - 136 HP - 100 kW
Mot/Eng: EW10J4 - Depol. US83
(A) -12/01
(B) 12/01-
Type/Typ: NORFN3

CI16066 **CAT**

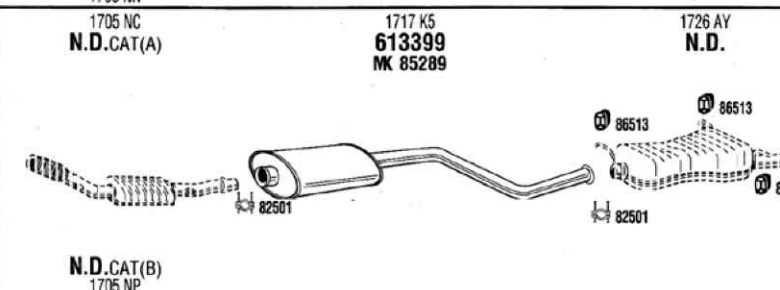

Xsara Entreprise
1.5 Diesel
05/98-08/00

1527 cc - 57 HP - 42 kW
Mot/Eng: TUD5
only Portugal
Type/Typ: N4
TSN: 676

CI16038 **CAT**

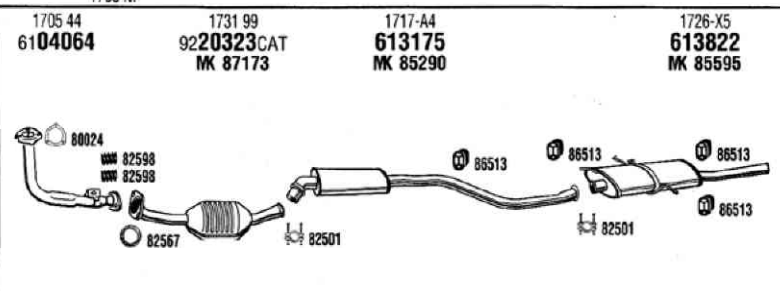

Xsara Entreprise
1.5 Diesel
05/98-08/00

1527 cc - 57 HP - 42 kW
Mot/Eng: TUD5
only Portugal
Type/Typ: N3

CI16037 **CAT**

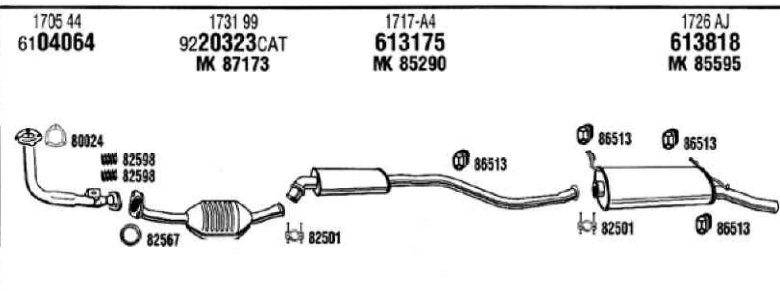

● En desarrollo



Los nombres y números de primer equipo se utilizan solamente como referencia

IMPORTANTE:



Al pedir sistemas de escape, rogamos completen la referencia comenzando por 'MFO.' (ejemplo: 381394 → MFO.381394)
Pour commander echappement, nous vous prions de compléter la référence en commençant par MFO..
When ordering exhaust, please complete the reference by beginning with MFO..

Fonos

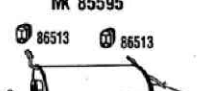

Citroën

<p>1721 28 613509</p>  <p>81164 82567</p>  <p>1705-T4 9820311CAT MK 87173</p> <p>48</p> <p>6507579(C) 1705T4SP22</p>	<p>1726 AJ 613818(A) MK 85595</p>  <p>86513 86513</p> <p>82501 82501</p> <p>86513 86513</p> <p>MK 85595 613822(B) 1726-X5</p>
---	--



Xsara
Hatchback -  **Entreprise**
1.8 Diesel
05/98-05/99
1769 cc - 60 HP - 44 kW
Mot/Eng: XUD7
(A) Hatchback (B) 
(C) Repair pipe Cat 20311
Type/Typ: N3-N4
CI16053 CAT

<p>1705 AS 9720314CAT MK 87199</p>  <p>80137</p>	<p>1726 AJ 613818(A) MK 85595</p>  <p>86513 86513</p> <p>82501 82501</p> <p>86513 86513</p> <p>MK 85595 613885(B) 1726 GW</p>
---	--



Xsara
Hatchback -  - 
1.9 Diesel
09/98-08/00
1868 cc - 69 HP - 51 kW
Mot/Eng: DW8
(A) Hatchback (B) 
Type/Typ: N0-N1-N2-N3-N4
CI16054 CAT

<p>1705 JE 9820580CAT(A)</p>  <p>80137</p>	<p>1726 AJ 613818 MK 85595</p>  <p>86513 86513</p> <p>82501 82501</p> <p>86513 86513</p> <p>● 9820721CAT(B) 1705SR</p>
---	--



Xsara
Hatchback
1.9 Diesel
09/00-
1868 cc - 69 HP - 51 kW
Mot/Eng: DW8B
Type/Typ: N1WJYB
Emission:(A) Euro III
Emission:(B) Euro II
CI16071 CAT

<p>1705 JE 9820580CAT(A)</p>  <p>80137</p>	<p>1726 GW 613385 MK 85595</p>  <p>86513 86513</p> <p>82501 82501</p> <p>86513 86513</p> <p>● 9820721CAT(B) 1705SR</p>
---	--

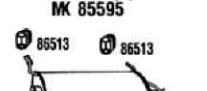
Xsara
 - 
1.9 Diesel
09/00-
1868 cc - 69 HP - 51 kW
Mot/Eng: DW8B
Type/Typ: N2WJYB
Emission:(A) Euro III
Emission:(B) Euro II
CI16072 CAT

<p>1721 28 613509</p>  <p>81164 82567</p>  <p>1705-T4 9820311CAT MK 87173</p> <p>48</p> <p>6507579(C) 1705T4SP22</p>	<p>1726 AJ 613818(A) MK 85595</p>  <p>86513 86513</p> <p>82501 82501</p> <p>86513 86513</p> <p>MK 85595 613822(B) 1726-X5</p>
---	--

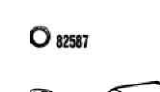
Xsara
Hatchback - 
1.9 Diesel
07/97-05/99
1905 cc - 69 HP - 51 kW
Mot/Eng: XUD9A
(A) Hatchback (B) 
(C) Repair pipe Cat 20311
Type/Typ: N0-N1-N2-N3
TSN: 647-684-685
CI16055 CAT

<p>1731-87 9220315CAT MK 21644</p>  <p>82587</p> <p>82598 82598</p>	<p>1717-98 613931 MK 85290</p>  <p>82501</p>	<p>1726-S8 613932(A)</p>  <p>86513 86513</p> <p>82516 82516</p> <p>86513 86513</p> <p>MK 85595 613930(B) 1726-X6</p>
--	--	---

Xsara
SD Hatchback - 
1.9 TD
01/98-05/99
1905 cc - 75 HP - 55 kW
Mot/Eng: XUD9BSD
(A) Hatchback (B) 
Type/Typ: N0-N2
TSN: 685-705-706
CI16056 CAT

Los nombres y números de primer equipo se utilizan solamente como referencia

● En desarrollo

IMPORTANTE:

Al pedir sistemas de escape, rogamos completen la referencia comenzando por 'MFO.' (ejemplo: 381394 → MFO.381394)



Pour commander echappement, nous vous prions de compléter la référence en commençant par MFO..

When ordering exhaust, please complete the reference by beginning with MFO..

ESCAPE / ECHAPPEMENT / EXHAUST

MOTOR / MOTEUR / ENGINE

Citroën

Xsara
Hatchback - 
1.9 TD
07/97-08/00
1905 cc - 90 HP - 66 kW
Mot/Eng: XUD9TE
(A) Hatchback (B) 
Type/Typ: NC-N1-N2
TSN: 646-685

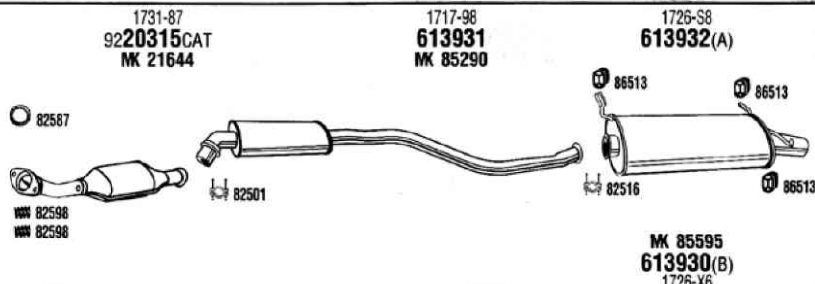

CI16057 **CAT**

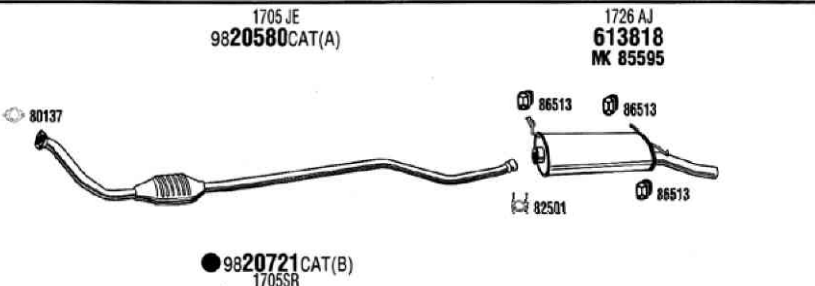

Xsara
Coupé
1.9 Diesel
09/00-
1868 cc - 69 HP - 51 kW
Mot/Eng: DW8B
Type/Typ: NOWJYB
Emission: (A) Euro III
Emission: (B) Euro II

CI16070 **CAT**



Xsara
Hatchback - 
2.0 HDi
06/99-08/00
1997 cc - 90 HP - 66 kW
Mot/Eng: DW10TD
(A) Hatchback (B) 
Type/Typ: N0- N1-N2

CI16058 **CAT**

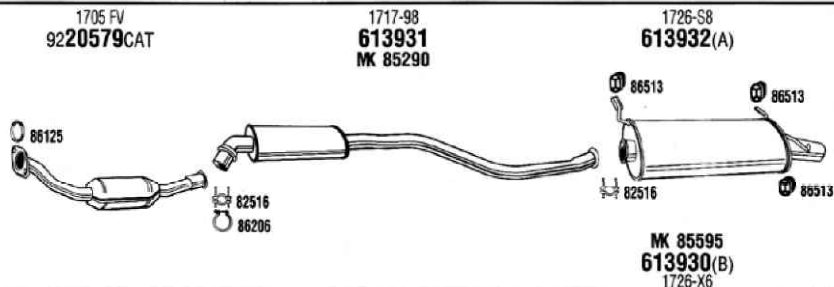

Xsara
Hatchback-Coupé
2.0 HDi
09/00-
1997 cc - 90 HP - 66 kW
Mot/Eng: DW10TD
(A) -01/02 - (B) 01/02-
Type/Typ: NORHYB-N1RHYB

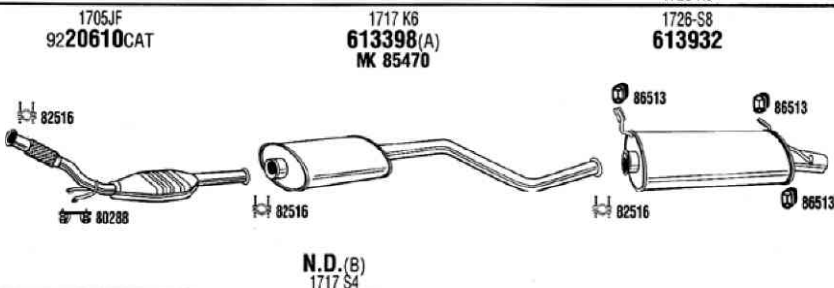

CI16059 **CAT**

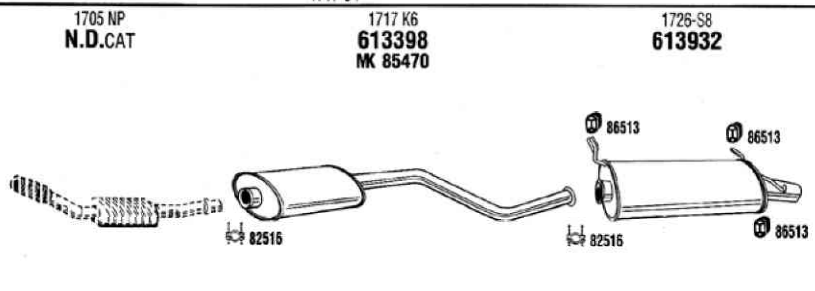

Xsara
Hatchback - Coupé
2.0 HDi
05/01-
1997 cc - 109 HP - 80 kW
Mot/Eng: DW10ATED
Type/Typ: NOR-N1R

CI16079 **CAT**



Xsara
 
2.0 HDi
09/00-
1997 cc - 90 HP - 66 kW
Mot/Eng: DW10TD
(A) -01/02 - (B) 01/02-
Type/Typ: N1RHYB-N2RHYB

CI16060 **CAT**

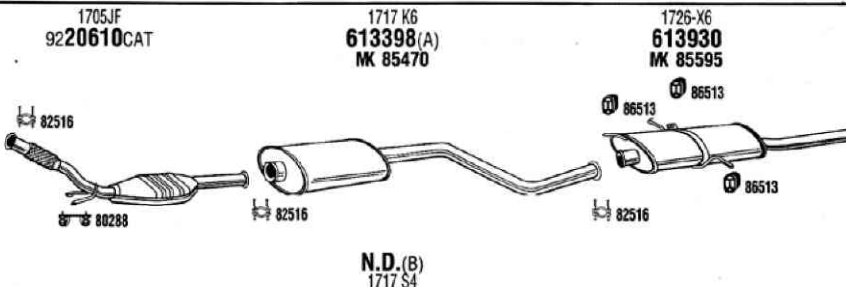

● En desarrollo



Los nombres y números de primer equipo se utilizan solamente como referencia

IMPORTANTE:

Al pedir sistemas de escape, rogamos completen la referencia comenzando por 'MFO.' (ejemplo: 381394 → MFO.381394)
Pour commander echappement, nous vous prions de compléter la référence en commençant par MFO..
When ordering exhaust, please complete the reference by beginning with MFO..

Fonos

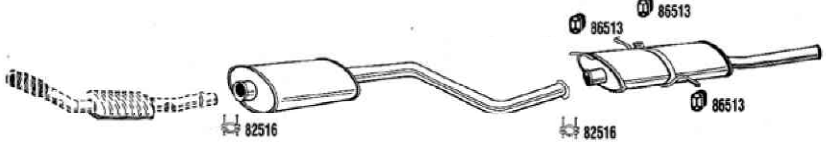
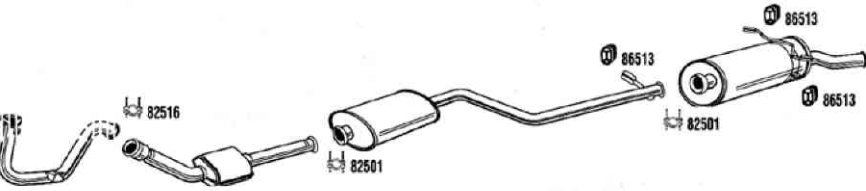
Citroën

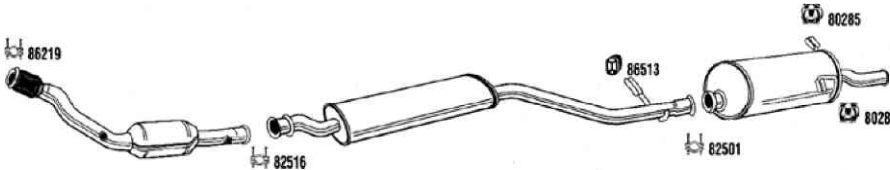
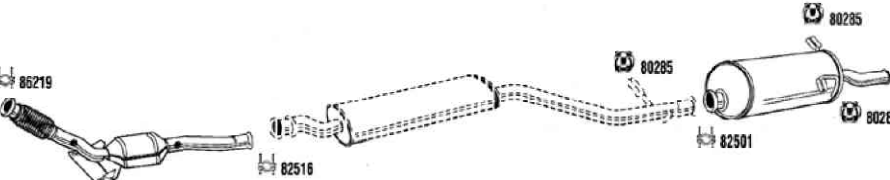
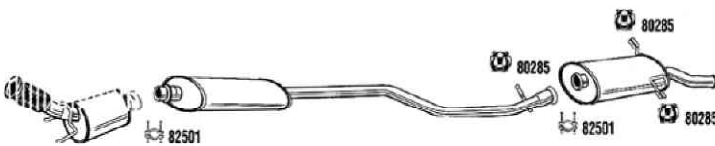
<p>1705 NP N.D.CAT</p> <p>1717 K6 613398 MK 85470</p> <p>1726-X6 613930 MK 85595</p> 	<p>Xsara</p> <p>2.0 HDi 05/01- 1997 cc - 109 HP - 80 kW Mot/Eng: DW10ATED Type/Typ: N2R</p> <p>CI16080 CAT</p>
<p>1705 FP N.D.</p> <p>1731 JO 9220577CAT</p> <p>1717 G1 613179 MK 85863</p> <p>1726EN 613844</p> 	<p>Xsara Picasso MPV 1.6 09/99- 1587 cc - 90 HP - 66 kW Mot/Eng: TU5JP DEPOL.CEE95 Type/Typ: CHNFZA</p> <p>CI16042 CAT</p>
<p>1731 N1 9220576CAT</p> <p>1717 K7 613182</p> <p>1726EN 613844</p> 	<p>Xsara Picasso MPV 1.6 09/99- 1587 cc - 95 HP - 70 kW Mot/Eng: TU5JP DEPOL.L4 Type/Typ: CHNFVB</p> <p>CI16043 CAT</p>
<p>1705 FS 9220590CAT</p> <p>1717 G3 613181 MK 85865</p> <p>1726TV 613843</p> 	<p>Xsara Picasso MPV 1.8 09/99- 1749 cc - 116 HP - 85 kW Mot/Eng: EW7J4 Type/Typ: CH6FZB-CH6FZC W/O Electronic Stability Program</p> <p>CI16044 CAT</p>
<p>1705SV 9320730CAT</p> <p>1717T6 N.D.</p> <p>1726TV 613843</p> 	<p>Xsara Picasso MPV 1.8 09/99- 1749 cc - 116 HP - 85 kW Mot/Eng: EW7J4 Type/Typ: CH6FZB-CH6FZC W/ Electronic Stability Program</p> <p>CI16085 CAT</p>
<p>1705KY N.D.CAT</p> <p>1717P5 613535</p> <p>1726KJ 613485</p> 	<p>Xsara Picasso MPV 2.0 05/01- 1997 cc - 136 HP - 100 kW Mot/Eng: EW10J4 Type/Typ: CHRFBM</p> <p>CI16081 CAT</p>

Los nombres y números de primer equipo se utilizan solamente como referencia

● En desarrollo

IMPORTANTE:

Al pedir sistemas de escape, rogamos completen la referencia comenzando por 'MFO.' (ejemplo: 381394 → MFO.381394)

Pour commander echappement, nous vous prions de compléter la référence en commençant par MFO..

When ordering exhaust, please complete the reference by beginning with MFO..

ESCAPE / ECHAPPEMENT / EXHAUST

MOTOR / MOTEUR / ENGINE

Citroën

Fonos

Xsara Picasso
MPV
 1.6 HDi
03/04-
 1560 cc - 110 HP - 80 kW
 Mot/Eng: DV6TED4
 Type/Typ: CH9
 Emission: Euro 2000

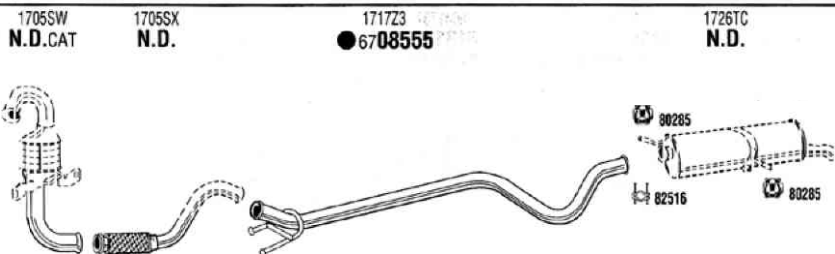

CI16084 **CAT**

Xsara Picasso
MPV
 1.6 HDi
03/04-
 1560 cc - 110 HP - 80 kW
 Mot/Eng: DV6TED4
 Type/Typ: CH9
 Emission: Euro 2005

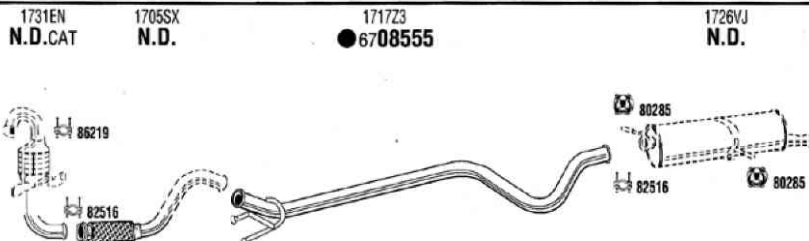

CI16083 **CAT**

Xsara Picasso
MPV
 2.0 HDi
09/99-02/02
 1997 cc - 90 HP - 66 kW
 Mot/Eng: DW10TD
 Type/Typ: CHRHYA-CHRHYB

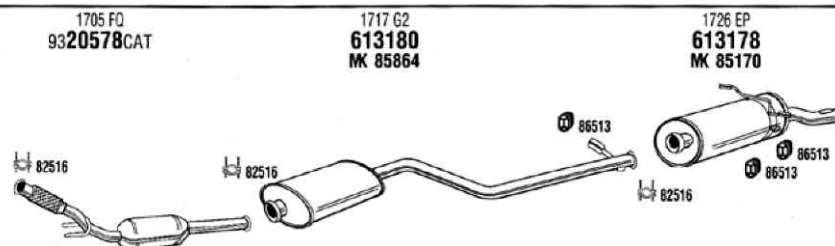

CI16045 **CAT**

Xsara Picasso
MPV
 2.0 HDi
02/02-
 1997 cc - 90 HP - 66 kW
 Mot/Eng: DW10TD
 Type/Typ: CHRHYA-CHRHYB

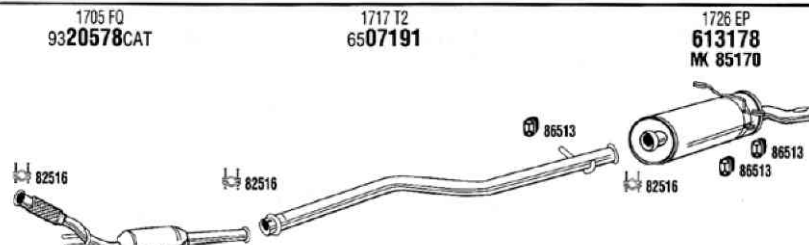

CI16082 **CAT**

ZX
Reflex
 1.1
03/91-07/92
 1124 cc - 60 HP - 44 kW
 Mot/Eng: TU1/K
 Type/Typ: N2A1

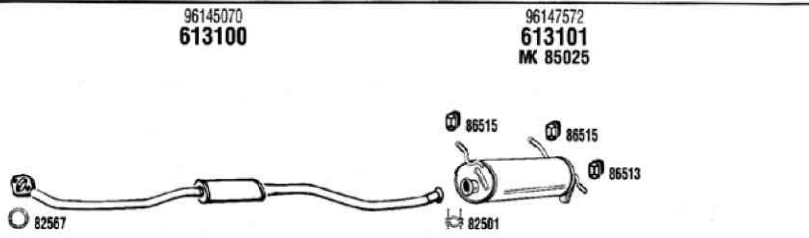

CI25004

ZX
Reflex-Flash
 1.1i
07/92-06/95
 1124 cc - 60 HP - 44 kW
 Mot/Eng: TU1M (Single Point Inj.)
 ch.no. -PR6785
 Type/Typ: N2A2-N2A4

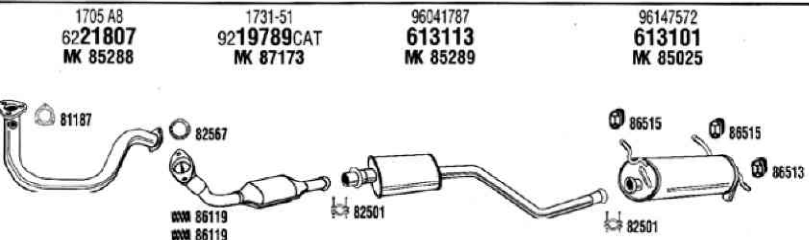

CI25007 **CAT**

● En desarrollo

Los nombres y números de primer equipo se utilizan solamente como referencia

IMPORTANTE:

Al pedir sistemas de escape, rogamos completen la referencia comenzando por 'MFO.' (ejemplo: 381394 → MFO.381394)
 Pour commander echappement, nous vous prions de compléter la référence en commençant par MFO..
 When ordering exhaust, please complete the reference by beginning with MFO..

Fonos

MOTOR / MOTEUR / ENGINE

1705 A8 6221807 MK 85288	1731-51 9219789CAT MK 87173	96041787 613113 MK 85289	1726K9 613714 MK 85152
--------------------------------	-----------------------------------	--------------------------------	------------------------------

λ1 87854	87912	87999	λ2 87853	87905	87999	λ3 87854	87919
----------	-------	-------	----------	-------	-------	----------	-------

7317541

ZX
Reflex-Flash
1.1i
07/95-98
1124 cc - 60 HP - 44 kW
Mot/Eng: TU1M (Single Point Inj.)
ch.no. PR6786-
(A) With chrome tailpipe
Type/Typ: N2A2-N2A4
λ1=07/95-08/96 - λ2=09/96-00/98 EURO96
λ3=09/96-00/98 ECE 15.04
CI25038 **CAT**

1705 48 313110 MK 85288	96145070 613100	96147572 613101 MK 85025
-------------------------------	--------------------	--------------------------------

λ1 87854	87910	87999x2
----------	-------	---------

7315916

ZX
Reflex-Avantage
1.4
03/91-07/92
1360 cc - 75 HP - 55 kW
Mot/Eng: TU3/2K
Type/Typ: N2A7
CI25001

96107090 N.D.	1731-51 9219789CAT MK 87173	96041787 613113 MK 85289	96147572 613101 MK 85025
------------------	-----------------------------------	--------------------------------	--------------------------------

λ1 87854	87910	87999x2
----------	-------	---------

7317541

ZX
Reflex-Aura-Avantage
1.4i
03/91-06/95
1360 cc - 75 HP - 55 kW
Mot/Eng: TU3MC/LZ (Single Point Inj.)
ch.no. -PR6785
Type/Typ: N2B1-N2A9
TSN: 208
CI25010 **CAT**

1705C9 N.D.	1731-51 9219789CAT MK 87173	96041787 613113 MK 85289	96147572 613101 MK 85025
----------------	-----------------------------------	--------------------------------	--------------------------------

λ1 87854	87910	87999x2
----------	-------	---------

7317541

ZX
Aura-Avantage
1.4i
03/91-06/95
1360 cc - 75 HP - 55 kW
Mot/Eng: TU3M/Z (Single Point Inj.)
ch.no. - PR5790
CI25016 **CAT**

1705 C0 6221811 MK 85288	1731-51 9219789CAT MK 87173	96041787 613113 MK 85289	1726K9 613714 MK 85152
--------------------------------	-----------------------------------	--------------------------------	------------------------------

λ1 87854	87912	87999x2
----------	-------	---------

7317541

ZX
Reflex-Aura-Avantage
1.4i
07/95-98
1360 cc - 75 HP - 55 kW
Mot/Eng: TU3MC/LZ (Single Point Inj.)
ch.no. PR6786-
(A) With chrome tailpipe
Type/Typ: N2B1-N2A9 - TSN: 208
λ1=Eng.KDX
λ2=Eng.KFX
CI25039 **CAT**

1705 C0 6221811 MK 85288	1731-51 9219789CAT MK 87173	96041787 613113 MK 85289	96145084 613114 MK 85025
--------------------------------	-----------------------------------	--------------------------------	--------------------------------

λ1 87854	87910	87999x2	λ2 87854	87912	87999	λ3 87854	87912
----------	-------	---------	----------	-------	-------	----------	-------

7317541

ZX
Prestige
1.4i
06/94-98
1360 cc - 75 HP - 55 kW
Mot/Eng: TU3MC/LZ (Single Point Inj.)
Type/Typ: N2B1 - TSN: 208
λ1=06/94-06/95
λ2=07/95-00/98 exc. ABS/ARC0
λ3=07/95-00/98 ABS/ARC0/Eng.Start Protection Syst.
CI25040 **CAT**

Los nombres y números de primer equipo se utilizan solamente como referencia ● En desarrollo

IMPORTANTE:

Al pedir sistemas de escape, rogamos completen la referencia comenzando por 'MFO.' (ejemplo: 381394 → MFO.381394)
Pour commander echappement, nous vous prions de compléter la référence en commençant par MFO..
When ordering exhaust, please complete the reference by beginning with MFO..

ESCAPE / ECHAPPEMENT / EXHAUST

MOTOR / MOTEUR / ENGINE

Citroën

Fonos

ZX

Flash-Tonic 

1.4i
06/94-98
 1361 cc - 75 HP - 55 kW
 Mot/Eng: TU3MC
 Type/Typ: N2D7 - TSN: 240
 λ¹=06/94->06/95
 λ²=07/95->00/98 exc.ABS/AIRCO
 λ³=07/95->00/98 ABS/AIRCO/Eng.Start Protection Syst.

1705-C0 6221811 MK 85288	1731-51 9219789CAT MK 87173	96041787 613113 MK 85289	1726-98 613194 MK 85025
---------------------------------------	--	---------------------------------------	--------------------------------------

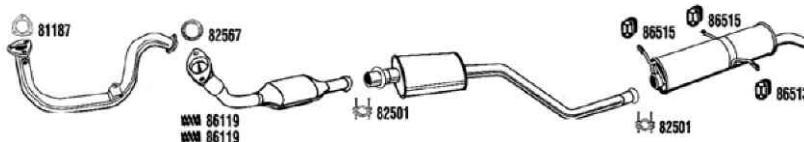

CI25026 **CAT**

λ ¹ 87854	87910	87999x2	λ ² 87854	87912	87999	λ ³ 87854	87912
----------------------	-------	---------	----------------------	-------	-------	----------------------	-------

7317541

ZX

1.4 Diesel
06/94-96
 1360 cc - 50 HP - 37 kW
 Mot/Eng: XUD3
 Type/Typ: N2H6

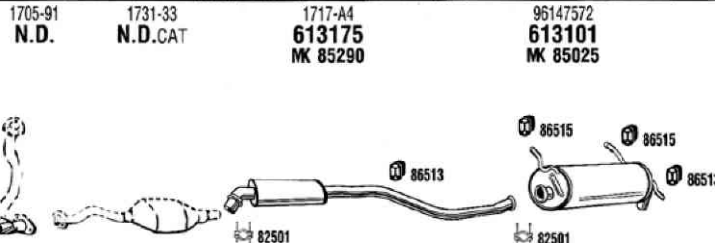

CI25024 **CAT**

7317552

ZX

Aura
 1.6i
03/91-07/92
 1580 cc - 89 HP - 65 kW
 Mot/Eng: XU5M-XU5/4K (Single Point Inj.)
 Type/Typ: N2B2

96087628 613102 MK 85451	96147572 613101 MK 85025
---------------------------------------	---------------------------------------

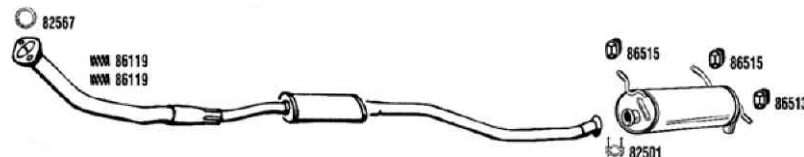

CI25002

7315919

ZX

Aura-Avantage Hatchback
 1.6i
03/91-98
 1580 cc - 89 HP - 65 kW
 Mot/Eng: XU5M/4Z (Single Point Inj.)
 TSN: 209
 λ¹=02/92->00/98

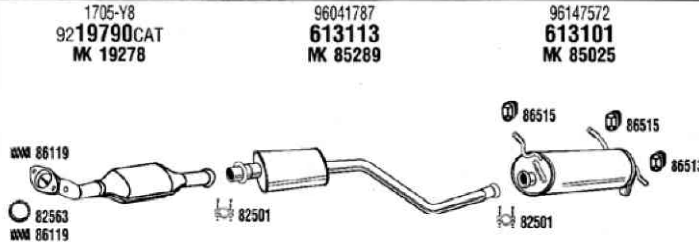

CI25017 **CAT**

λ ¹ 87854	87910	87999x2
----------------------	-------	---------

7317541

ZX

Aura-Avantage-Fugue
 1.6i
07/92-98
 1580 cc - 89 HP - 65 kW
 Mot/Eng: XU5M3/L (Single Point Inj.)
 Type/Typ: N2G1-N2J9
 TSN: 209

1705-Y8 9219790CAT MK 19278	96041787 613113 MK 85289	96147572 613101 MK 85025
--	---------------------------------------	---------------------------------------

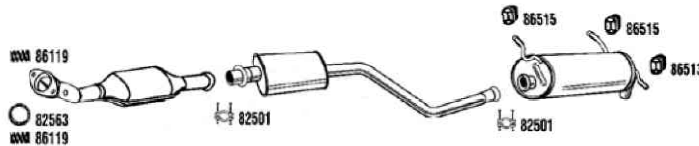

CI25011 **CAT**

λ ¹ 87854	87910	87999x2
----------------------	-------	---------

7317541

ZX

Aura-Avantage-Fugue 
 1.6i
06/94-98
 1580 cc - 89 HP - 65 kW
 Mot/Eng: XU5JP (Multi Point Inj.)
 Type/Typ: N2G2
 TSN: 242
 λ¹=06/94->04/95
 λ²=05/95->98

1705-Y8 9219790CAT MK 19278	96041787 613113 MK 85289	1726-98 613194 MK 85025
--	---------------------------------------	--------------------------------------

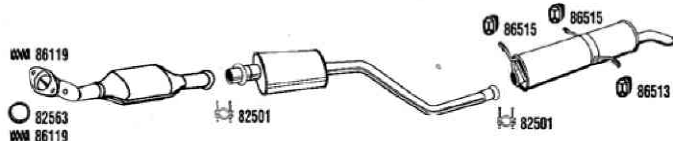

CI25028 **CAT**

λ ¹ 87854	87910	87999x2	λ ² 87854	87912	87999
----------------------	-------	---------	----------------------	-------	-------

7317541

● En desarrollo

Los nombres y números de primer equipo se utilizan solamente como referencia

IMPORTANTE:

Al pedir sistemas de escape, rogamos completen la referencia comenzando por 'MFO.' (ejemplo: 381394 → MFO.381394)
 Pour commander echappement, nous vous prions de compléter la référence en commençant par MFO..
 When ordering exhaust, please complete the reference by beginning with MFO..

1705-Y8 9219790CAT MK 19278	96041787 613113 MK 85289	96147572 613101 MK 85025
-----------------------------------	--------------------------------	--------------------------------

λ1 87854	87910	87999x2	λ2 87854	87912	87999
----------	-------	---------	----------	-------	-------

7317541

ZX
Aura
1.8i
07/92-98
1761 cc - 101 HP - 74 kW
Mot/Eng: XU7JP/LZ (Multi Point Inj.)
Type/Typ: N2E4
TSN: 218
λ1=07/92->04/95
λ2=05/95->00/98

CAT

1705-Y8 9219790CAT MK 19278	96041787 613113 MK 85289	96145084 613114 MK 85025
-----------------------------------	--------------------------------	--------------------------------

λ1 87854	87910	87999x2	λ2 87854	87912	87999
----------	-------	---------	----------	-------	-------

7317541

ZX
Prestige-Furio
1.8i
07/92-98
1761 cc - 101 HP - 74 kW
Mot/Eng: XU7JP/LZ (Multi Point Inj.)
Type/Typ: N2E3
TSN: 218
λ1=07/92->04/95
λ2=05/95->00/98

CAT

1705-Y8 9219790CAT MK 19278	96041787 613113 MK 85289	1726-98 613194 MK 85025
-----------------------------------	--------------------------------	-------------------------------

λ1 87854	87910	87999x2	λ2 87854	87912	87999
----------	-------	---------	----------	-------	-------

7317541

ZX
1.8i
94-98
1761 cc - 103 HP - 76 kW
Mot/Eng: XU7JP
λ1=00/94->04/95
λ2=05/95->00/98

CAT

1705-Y8 9219790CAT MK 19278	96041787 613113 MK 85289	1726-98 613194 MK 85025
-----------------------------------	--------------------------------	-------------------------------

λ1 87854	87910	87999x2	λ2 87854	87912	87999
----------	-------	---------	----------	-------	-------

7317541

ZX
Aura-Furio-Avantage
1.8i
06/94-98
1761 cc - 101 HP - 74 kW
Mot/Eng: TU7JP/LZ (Multi Point Inj.)
TSN: 239
λ1=06/94->04/95
λ2=05/95->00/98

CAT

96041778 613104	96070794 613105 MK 85025
--------------------	--------------------------------

λ1 87854	87910	87999x2
----------	-------	---------

7315922

ZX
Volcane
1.9i
03/91-07/92
1905 cc - 130 HP - 96 kW
Mot/Eng: XU9JA
Type/Typ: N2B6

CAT

96081984 9220312CAT MK 19278	96041788 613117 MK 85289	96070794 613105 MK 85025
------------------------------------	--------------------------------	--------------------------------

λ1 87854	87910	87999x2
----------	-------	---------

7317545

ZX
Volcane
1.9i
03/91-07/94
1905 cc - 122 HP - 88 kW
Mot/Eng: XU9JAZ (Multi Point Inj.)
Type/Typ: N2B8
TSN: 210

CAT

Los nombres y números de primer equipo se utilizan solamente como referencia

● En desarrollo

IMPORTANTE:

Al pedir sistemas de escape, rogamos completen la referencia comenzando por 'MFO.' (ejemplo: 381394 → MFO.381394)
 Pour commander echappement, nous vous prions de compléter la référence en commençant par MFO..
 When ordering exhaust, please complete the reference by beginning with MFO..

ESCAPE / ECHAPPEMENT / EXHAUST

MOTOR / MOTEUR / ENGINE

Citroën

Fonos

ZX
Volcane
 2.0i
07/92-02/00
 1998 cc - 123 HP - 90 kW
 Mot/Eng: XU10J2C (Multi Point Inj.)
 Type/Typ: N2E6-N2E7
 TSN: 220
 λ¹=07/92->04/95
 λ²=05/95->02/00

96143273
N.D.CAT

171739
613546
 MK 85289

96142630
613148
 MK 85025

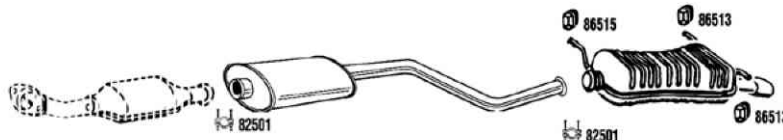

CI25014 **CAT**

λ¹ 87854 87910 87999x2 λ² 87854 87912 87999

7317545

ZX
Hatchback
 2.0i 16v
07/95-07/98
 1998 cc - 166 HP - 122 kW
 Mot/Eng: XU10J4RS
 Type/Typ: N2

1706 L9
9220388CAT
 MK 21826

171739
613546
 MK 85289

1726N1
N.D.

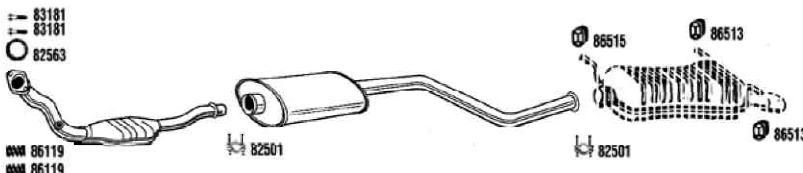

CI25064 **CAT**

ZX
Coupé
 2.0i 16v
07/92-02/00
 1998 cc - 155 HP - 114 kW
 Mot/Eng: XU105AD (Multi Point Inj.)
 Type/Typ: N2F1
 TSN: 221
 λ¹=07/92->04/95
 λ²=05/95->02/00
CI25015

96141868
N.D.CAT

171739
613546
 MK 85289

96142630
613148
 MK 85025

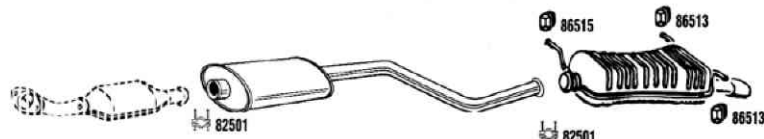

CI25015 **CAT**

λ¹ 87854 87910 87999x2 λ² 87854 87912 87999

7317545

ZX
Enterprise
 1.8 Diesel
06/94-96
 1769 cc - 60 HP - 44 kW
 Mot/Eng: XUD7
 Type/Typ: N2C2/T

1721 28
613509

96041781
613118
 MK 85451

96147572
613101
 MK 85025

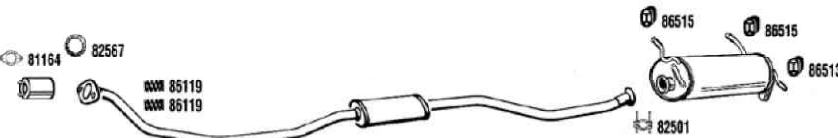

CI25021

ZX
Reflex-Aura-Avantage
 1.9 Diesel
09/91-06/92
 1905 cc - 64 HP - 47 kW
 Mot/Eng: XUD9A
 Type/Typ: N2C3-N2C4
 TSN: 214

96041781
613118
 MK 85451

96147572
613101
 MK 85025

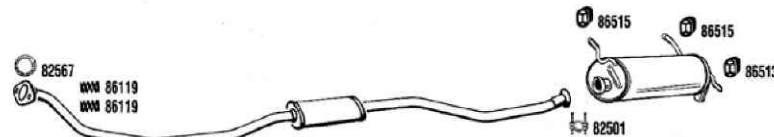

CI25005

ZX
Reflex-Aura-Avantage
 1.9 Diesel
07/92-06/94
 1905 cc - 71 HP - 52 kW
 Mot/Eng: XUD9A
 Type/Typ: N2C3-N2C4-N2C4/T
 TSN: 261

1721 28
613509

96041781
613118
 MK 85451

96147572
613101
 MK 85025

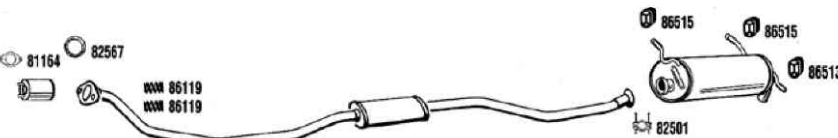

CI25022

7317373

● En desarrollo

Los nombres y números de primer equipo se utilizan solamente como referencia

IMPORTANTE:

Al pedir sistemas de escape, rogamos completen la referencia comenzando por 'MFO.' (ejemplo: 381394 → MFO.381394)
 Pour commander echappement, nous vous prions de compléter la référence en commençant par MFO..
 When ordering exhaust, please complete the reference by beginning with MFO..

1721 28
613509

96134334
9220635CAT

1717-A4
613175
MK 85290

96147572
613101
MK 85025

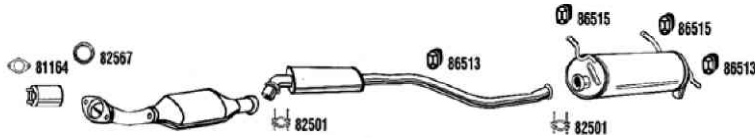

7317552

ZX
Reflex-Avantage
1.9 Diesel
07/92-05/94
1905 cc - 65 HP - 48 kW
Mot/Eng: XUD9A
TSN: 214

Ci25023 **CAT**

1721 28
613509

96041781
613118
MK 85451

96145084
613114
MK 85025

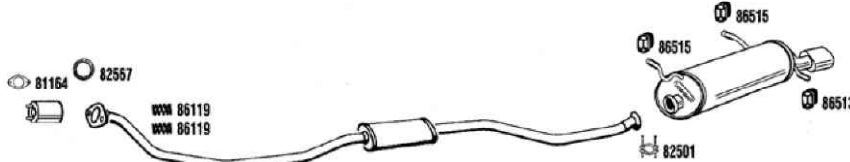

7317373

ZX
Prestige
1.9 Diesel
06/94-02/00
1905 cc - 71 HP - 52 kW
Mot/Eng: XUD9A
Type/Typ: N2C3-N2C4

Ci25042

1705-T4
9820311CAT
MK 87173

96147572
613101
MK 85025

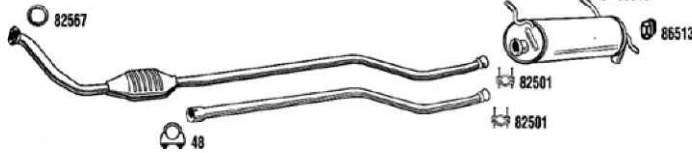

7317552

ZX
Reflex-Avantage
1.9 Diesel
06/94-02/00
1905 cc - 71 HP - 52 kW
Mot/Eng: XUD9A
(A) Repair pipe Cat 20311
Type/Typ: N2C3-N2C4
TSN: 261

Ci25045 **CAT**

1705-T4
9820311CAT
MK 87173

96145084
613114
MK 85025



7317552

ZX
Prestige
1.9 Diesel
06/94-02/00
1905 cc - 71 HP - 52 kW
Mot/Eng: XUD9A
(A) Repair pipe Cat 20311
Type/Typ: N2C3-N2C4
TSN: 261

Ci25043 **CAT**

1721 28
613509

96041781
613118
MK 85451

1726-98
613194
MK 85025

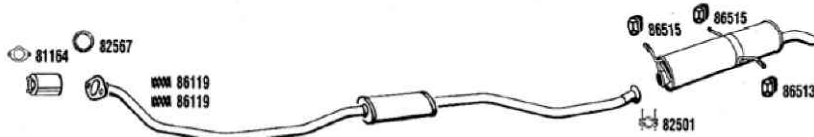

7317373

ZX
Flash-Fugue 
1.9 Diesel
06/94-02/00
1905 cc - 71 HP - 51 kW
Mot/Eng: XUD9A
Type/Typ: N2D5-N2H5
TSN: 262

Ci25029

1705-T4
9820311CAT
MK 87173

1726-98
613194
MK 85025

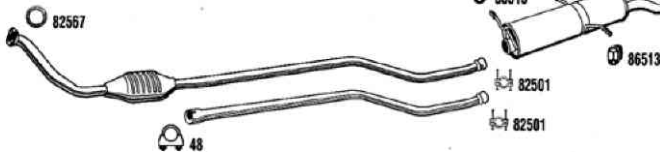

7317552

ZX
Fugue 
1.9 Diesel
06/94-02/00
1905 cc - 71 HP - 52 kW
Mot/Eng: XUD9A
(A) Repair pipe Cat 20311
Type/Typ: N2H5
TSN: 262

Ci25044 **CAT**

Los nombres y números de primer equipo se utilizan solamente como referencia

● En desarrollo

IMPORTANTE:

Al pedir sistemas de escape, rogamos completen la referencia comenzando por 'MFO.' (ejemplo: 381394 → MFO.381394)
Pour commander echappement, nous vous prions de compléter la référence en commençant par MFO..
When ordering exhaust, please complete the reference by beginning with MFO..

ESCAPE / ECHAPPEMENT / EXHAUST

Citroën



ZX
Aura-Avantage
 1.9 TD
07/92-02/00
 1905 cc - 92 HP - 68 kW
 Mot/Eng: XUD9TE
 Type/Typ: N2F4-N2F5

CI25019

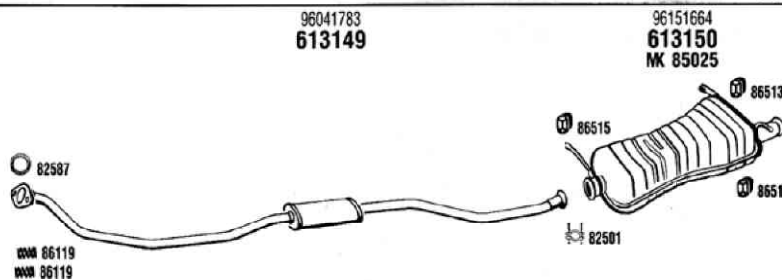

7317552

ZX
Aura-Avantage
 1.9 TD
07/92-02/00
 1905 cc - 90 HP - 66 kW
 Mot/Eng: XUD9TE
 Type/Typ: N2F4-N2F5
 TSN: 219

CI25020 **CAT**

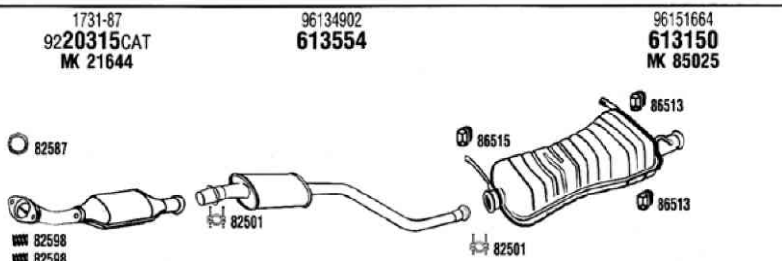

7317552

ZX
Volcane-Exclusive
 1.9 TD
07/92-02/00
 1905 cc - 92 HP - 68 kW
 Mot/Eng: XUD9TE
 Type/Typ: N2F4-N2F5

CI25027

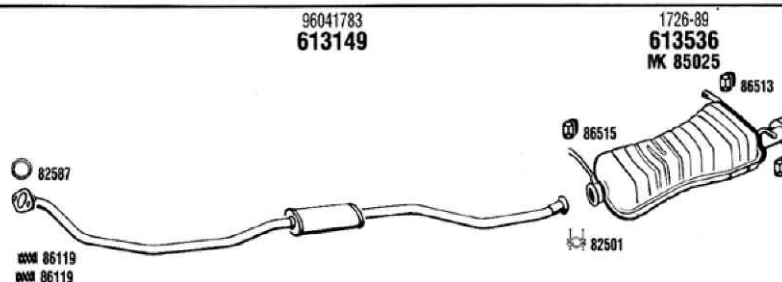

7317552

ZX
Volcane-Exclusive
 1.9 TD
06/94-02/00
 1905 cc - 90 HP - 66 kW
 Mot/Eng: XUD9TE
 Type/Typ: N2F4-N2F5
 TSN: 219

CI25025 **CAT**

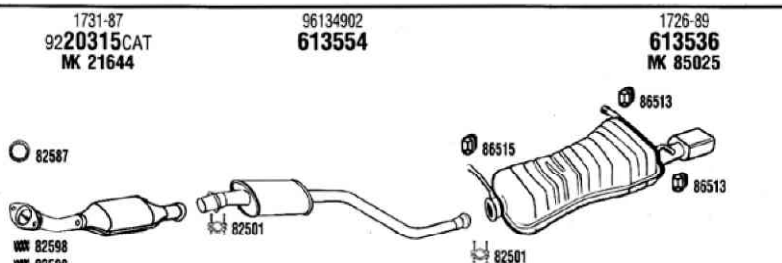

7317552

ZX
Aura-Avantage-Fugue 
 1.9 TD
10/93-02/00
 1905 cc - 92 HP - 68 kW
 Mot/Eng: XUD9TE
 Type/Typ: N2G5
 TSN: 241

CI25030

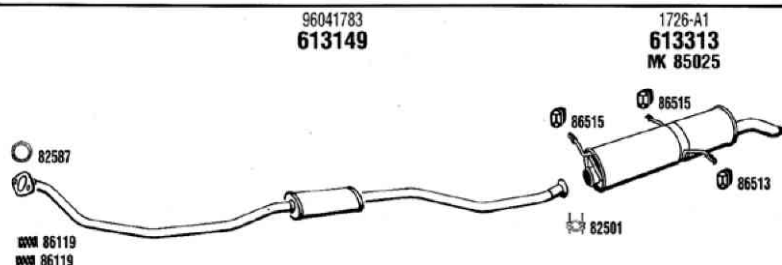

7317552

ZX
Aura-Avantage-Fugue 
 1.9 TD
06/94-02/00
 1905 cc - 90 HP - 66 kW
 Mot/Eng: XUD9TE
 Type/Typ: N2G2
 TSN: 241

CI25046 **CAT**

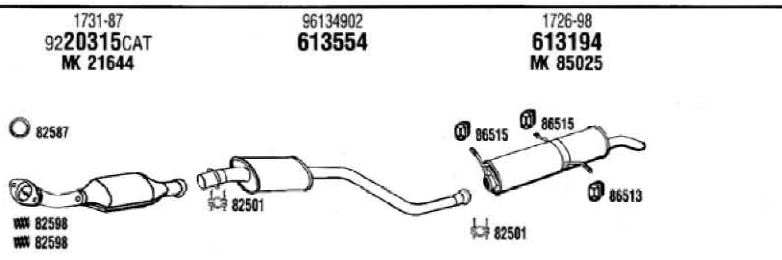

● En desarrollo

Los nombres y números de primer equipo se utilizan solamente como referencia

IMPORTANTE:

Al pedir sistemas de escape, rogamos completen la referencia comenzando por 'MFO.' (ejemplo: 381394 → MFO.381394)
 Pour commander echappement, nous vous prions de compléter la référence en commençant par MFO..
 When ordering exhaust, please complete the reference by beginning with MFO..

AM1821E 613201	AY1824 31321	AY1820 631332	AY18293A N.D.		2 CV6 Ami 6-Dyane 6 06/68- R.H.D.
				7301043	CH11016
AZ1831 N.D.	A1832B 5101002 ¹				2 CV 0.4 01/50-02/63 452 cc - 12.5 HP - 9 kW 250 kgs Type/Typ: AZ-AZL-AZAM-AU-AZU
					CH11006
AZ1831B N.D.	A1832B 5101002 ¹				2 CV 0.4 03/63-11/63 425 cc - 12.5 HP - 9 kW 250 kgs Type/Typ: AZL-AZAM-AU-AZU
					CH11007
AZ1831A 6101004 ¹	AZ1832B N.D.				2 CV 0.4, 0.6 12/63-07/72 425, 602 cc - 18, 29 HP - 13, 21 kW 250 kgs Type/Typ: AZL-AZAM-AU-AZU-AKL
					CH11008
75527203 613206	AY1824 31321	AY1820 631332	AZU18293 31324		2 CV6 0.6 05/68-12/86 602 cc - 31 HP - 23 kW AKB-350 kgs AKS-400 kgs Type/Typ: AKB-AKS TSN: 303
				7301031	CH11015
AYB1821 613242	AY1824 31321	AY1820 631332	AZ182293A 31323 MK 85078		2 CV4 0.4 03/70-12/78 401 cc - 24 HP - 18 kW Type/Typ: AZA-AZA2-AZL4-AZKB ISN: 351
				7301043	CH11010

Los nombres y números de primer equipo se utilizan solamente como referencia

● En desarrollo

IMPORTANTE:

Al pedir sistemas de escape, rogamos completen la referencia comenzando por 'MFO.' (ejemplo: 381394 → MFO.381394)
 Pour commander echappement, nous vous prions de compléter la référence en commençant par MFO..
 When ordering exhaust, please complete the reference by beginning with MFO..

ESCAPE / ECHAPPEMENT / EXHAUST

Citroën

2 CV4

0.4
03/70-12/78
401 cc - 24 HP - 18 kW
250 kgs
Type/Typ: AZU
TSN: 351

AYB1821 613242 AY1824 31321 AY1820 631332 AZU18293 31324

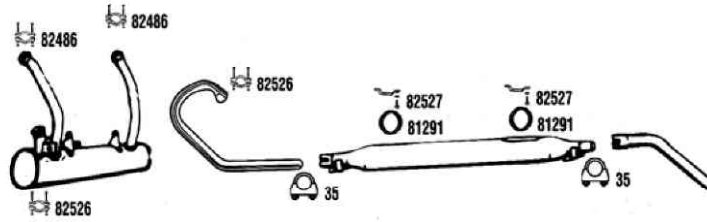

7301031

CI11011

2 CV6

0.6
03/70-10/90
602 cc - 24, 27, 29 HP - 18, 20, 21 kW
Type/Typ: AZL-AZL6-AZ serie KA
TSN: 303-430

75527203 613206 AY1824 31321 AY1820 631332 AZ182293A 31323 MK 85078

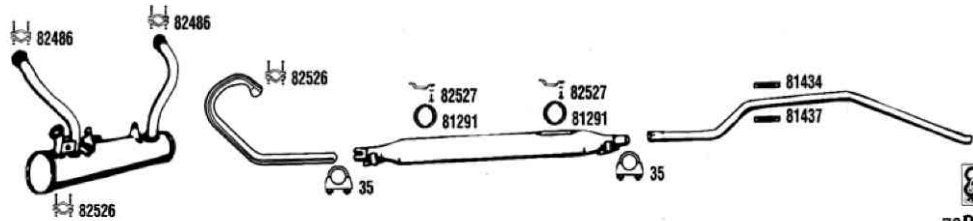

7301043

CI11013

IMPORTANTE:

Al pedir sistemas de escape, rogamos completen la referencia comenzando por 'MFO.' (ejemplo: 381394 → MFO.381394)
Pour commander echappement, nous vous prions de compléter la référence en commençant par MFO..
When ordering exhaust, please complete the reference by beginning with MFO..

0341-81 N.D.	1705-71 N.D.CAT	1726-A9 613197 MK 85738
-----------------	--------------------	-------------------------------

Boxer
2.0
03/94-01/02
1998 cc - 110 HP - 81 kW
Mot/Eng: XU10J2
ISN: 741, 764, 812
λ1=03/94->12/95
λ2=01/96->

λ1 87854	87910	87999x2	λ2 87854	87912
0341-85 N.D.	1705-72 6319286	1726-A9 613197 MK 85738		

PE85000 **CAT**
Boxer
1.9 Diesel
03/94-01/02
1905 cc - 71 HP - 51 kW
Mot/Eng: XUD9A
Type/Typ: 231A62
TSN: 024

1705-78 6319283	1726-A9 613197 MK 85738
--------------------	-------------------------------

7319290 PE85001
Boxer
1.9 TD
03/94-01/02
1905 cc - 93 HP - 68 kW
Mot/Eng: XUD9TE
TSN: 025

1705-74 N.D.CAT	1726-A9 613197 MK 85738
--------------------	-------------------------------

7319290 PE85002
Boxer
1.9 TD
03/94-01/02
1905 cc - 90 HP - 66 kW
Mot/Eng: XUD9TE
TSN: 766, 767, 816

N.D.	1705W7 613790	1726-A9 613197 MK 85738
------	------------------	-------------------------------

PE85003 **CAT**
Boxer
1.9 TD
03/94-01/02
1905 cc - 90 HP - 66 kW
Mot/Eng: XUD9TE

0341-76 N.D.	1705-78 6319283	1726-A9 613197 MK 85738
-----------------	--------------------	-------------------------------

PE85045
Boxer
2.5 Diesel
03/94-98
2445 cc - 86 HP - 63 kW
Mot/Eng: DJ5
ch.no. -15577562
Type/Typ: 23152-23252-23352
TSN: 026

Los nombres y números de primer equipo se utilizan solamente como referencia ● En desarrollo

IMPORTANTE:

Al pedir sistemas de escape, rogamos completen la referencia comenzando por 'MFO.' (ejemplo: 381394 → MFO.381394)
Pour commander echappement, nous vous prions de compléter la référence en commençant par MFO..
When ordering exhaust, please complete the reference by beginning with MFO..

ESCAPE / ECHAPPEMENT / EXHAUST

MOTOR / MOTEUR / ENGINE

Peugeot

2007 **Fonos**

Boxer
2.5 TD
03/94-01/02
2445 cc - 103 HP - 76 kW
Mot/Eng: DJ5T
TSN: 027

0341-77
N.D. 1705 75
9320443CAT 1726-A9
613197
MK 85738

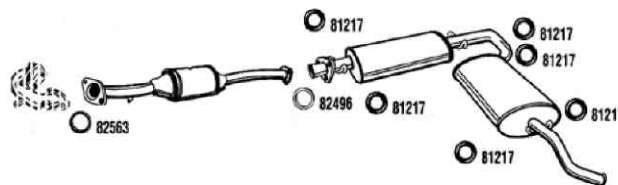

PE85005 **CAT**

Boxer Van
2.8 Diesel
06/99-01/02
2798 cc - 87 HP - 64 kW
Mot/Eng: 8140-63
Type/Typ: 232

0341E9
N.D. 1705FH
● 9320652CAT 1726-A9
613197
MK 85738

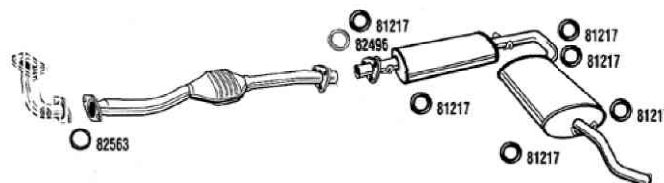

PE85044 **CAT**

Expert
1.6
02/96-
1581 cc - 79 HP - 58 kW
Mot/Eng: 222A2 (1530 SPI)
Type/Typ: 224

1705 F1
9221586CAT 1717 53
613187
MK 85467 1726 G8
613587
MK 85509

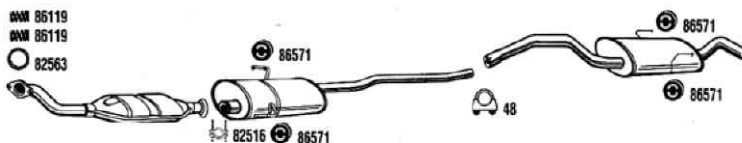

PEW82030 **CAT**

Expert
2.0 16v
07/00-
1997 cc - 136 HP - 100 kW
Mot/Eng: RFN (EW10J4)
Type/Typ: 224
To: (A) -06/01
From: (B) 06/01-

1705 JR
9320593CAT(A) 1717 LD
613288(A)
MK 85880 1726HG
613791

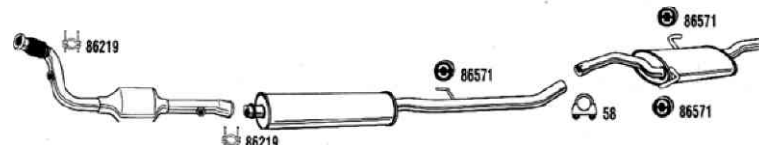

PEW82031 **CAT**

Expert
1.9 Diesel
02/96-
1905 cc - 70 HP - 51 kW
Mot/Eng: D9B (XUD9AU)
Type/Typ: 224

N.D.CAT(B) 1705NZ
1717Q7
610779(B) 1705-F2
613588
MK 85765 1726 G8
613587
MK 85509

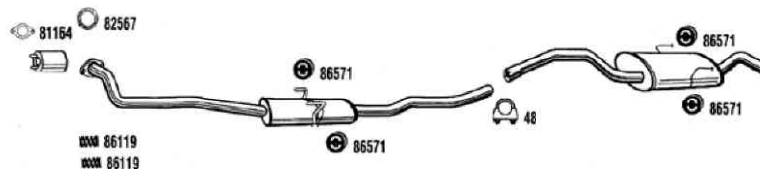

PEW82032

Expert
1.9 Diesel
12/98-05/00
1868 cc - 69 HP - 51 kW
Mot/Eng: WJY (DW8B), WJZ (DW8)
Type/Typ: 222
Wheelbase: (A) SWB
Wheelbase: (B) LWB

1705 AF
9320345CAT
MK 21644 1717 53
613187(A)
MK 85467 1726 G8
613587
MK 85509

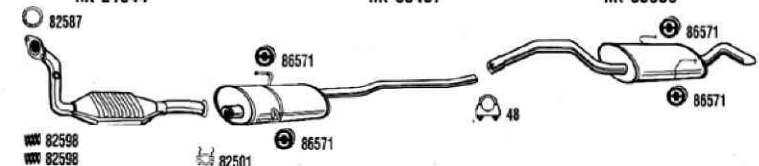

PEW82033 **CAT**

610605(B)
1717 F7

● En desarrollo

Los nombres y números de primer equipo se utilizan solamente como referencia

IMPORTANTE:

Al pedir sistemas de escape, rogamos completen la referencia comenzando por 'MFO.' (ejemplo: 381394 → MFO.381394)
Pour commander echappement, nous vous prions de compléter la référence en commençant par MFO..
When ordering exhaust, please complete the reference by beginning with MFO..

1705JN 9320645CAT	1717J6 610576(A)	1726HA 613755 MK 85881
613760(B) 1717J7		

Expert
1.9 Diesel
05/00-08/01
1868 cc - 69 HP - 51 kW
Mot/Eng: WJY (DW8B), WJZ (DW8)
Type/Typ: 222
Wheelbase:(A) SWB
Wheelbase:(B) LWB

PEW82034 **CAT**



1705NS ●610778	1705NT 9220653CAT(A)	1726HA 613755 MK 85881
N.D.CAT(B) 1705NV		

Expert
1.9 Diesel
09/01-
1868 cc - 69 HP - 51 kW
Mot/Eng: WJY (DW8B), WJZ (DW8)
Type/Typ: 222
Wheelbase:(A) SWB
Wheelbase:(B) LWB

PEW82035 **CAT**



1705 E1 6221583	1717 55 613193 MK 85508	1726 V4 613592 MK 85509

Expert
1.9 TD
02/96-
1905 cc - 90 HP - 66 kW
Mot/Eng: DHX (XUD9TE)
Type/Typ: 223

PEW82036

1705 E1 6221583	1717 55 613193 MK 85508	1726 V4 613592 MK 85509

Expert
1.9 TD
02/96-
1905 cc - 92 HP - 68 kW
Mot/Eng: D8B (XUD9TE)
Type/Typ: 222,223,224

PEW82037

1705 R7 9221584CAT	1717 55 613193 MK 85508	1726 V4 613592 MK 85509

Expert
1.9 TD
02/96-
1905 cc - 90 HP - 66 kW
Mot/Eng: DHX (XUD9TE)
Type/Typ: 223,224

PEW82038 **CAT**

1705 JJ 9220546CAT MK 21827	1717 J6 610576(A)	1726HE 615793
613760(B) 1717J7		

Expert
2.0 HDI
07/00-06/01
1997 cc - 94 HP - 69 kW
Mot/Eng: RHX (DW10BTD)
Type/Typ: 222
Wheelbase:(A) SWB
Wheelbase:(B) LWB

PEW82039 **CAT**

Los nombres y números de primer equipo se utilizan solamente como referencia

● En desarrollo

IMPORTANTE:

Al pedir sistemas de escape, rogamos completen la referencia comenzando por 'MFO.' (ejemplo: 381394 → MFO.381394)
Pour commander echappement, nous vous prions de compléter la référence en commençant par MFO..
When ordering exhaust, please complete the reference by beginning with MFO..

ESCAPE / ECHAPPEMENT / EXHAUST

Peugeot



Expert

2.0 HDI
06/01-
1997 cc - 94 HP - 69 kW
Mot/Eng: RHX (DW10BTE)
Type/Typ: 222
Wheelbase:(A) SWB
Wheelbase:(B) LWB

1705 NW 1717 Q5 1726HE
9220615CAT 613593(A) 615793

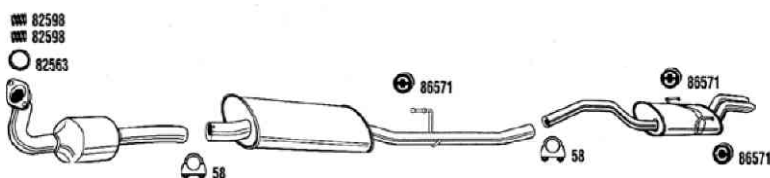

613761(B)
1717Q6

PEW82040 CAT

Expert

2.0 HDI
07/00-06/01
1997 cc - 109 HP - 80 kW
Mot/Eng: RHZ ,RHW(DW10ATED)
Type/Typ: 222,224
Wheelbase:(A) SWB
Wheelbase:(B) SWB

1705 JJ 1717 J6 1726HE
9220546CAT MK 21827 610576(A) 615793

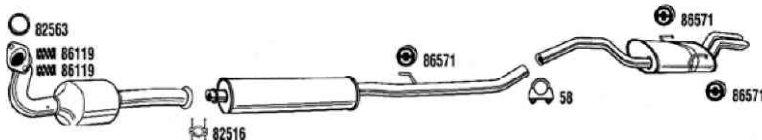

613760(B)
1717J7

PEW82041 CAT

Expert

2.0 HDI
06/01-
1997 cc - 109 HP - 80 kW
Mot/Eng: RHZ ,RHW(DW10ATED)
Type/Typ: 222,224
Wheelbase:(A) SWB
Wheelbase:(B) SWB

1705 NW 1717 Q5 1726HE
9220615CAT 613593(A) 615793

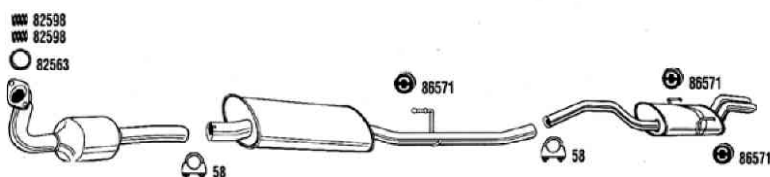

613761(B)
1717Q6

PEW82042 CAT

Expert

2.0 HDi
01/02-
1997 cc - 110 HP - 81 kW
Mot/Eng: RHZ (DW10CTED)
Type/Typ: B*
Wheelbase:(A) SWB

1705NX 1717 Q5 1726HE
N.D.CAT 613593(A) 615793

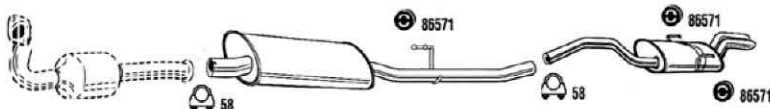

613761(B)
1717Q6

PEW82043 CAT

J5

1.8
11/81-08/91
1796 cc - 67 HP - 49 kW
Mot/Eng: XM7T
TSN: 006-010

1703-06 1721-20 1725-66 1725-81
6101486 610888 610889 613490
MK 85679 MK 85050

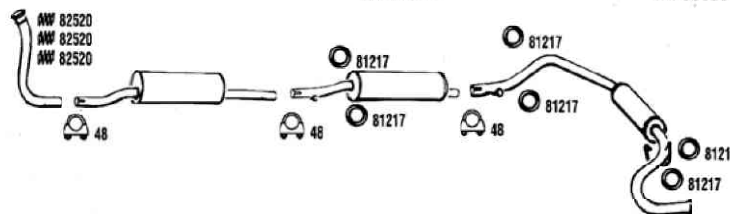

7301518

PE61102

J5

2.0
11/81-08/90
1971 cc - 75 HP - 55 kW
Mot/Eng: XN1P-XM7T
TSN: 011

1703-06 1721-20 1725-66 1725-81
6101486 610888 610889 613490
MK 85679 MK 85050

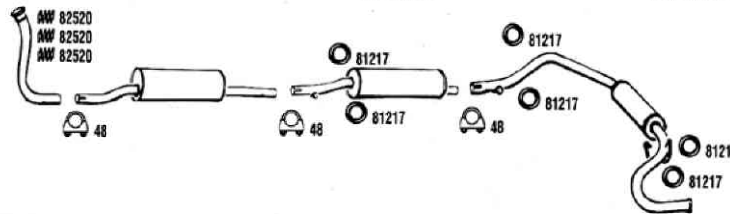

7301518







PE61115

● En desarrollo

Los nombres y números de primer equipo se utilizan solamente como referencia

IMPORTANTE:

Al pedir sistemas de escape, rogamos completen la referencia comenzando por 'MFO.' (ejemplo: 381394 → MFO.381394)
Pour commander echappement, nous vous prions de compléter la référence en commençant par MFO..
When ordering exhaust, please complete the reference by beginning with MFO..

1704-27 6117155 ¹	1721-35 5217156	1725-66 610889 MK 85679	1725-81 613490 MK 85050	<p>J5</p>  <p>2.0 09/90- 1971 cc - 85 HP - 62 kW Mot/Eng: XN1TA Type/Typ: 280AJ32/K32/42/B42/C42/D42 TSN: 017</p>
				<p>7317157 PE61108</p>
1704-53 6114220	1721-20 610888	1725-66 610889 MK 85679	1725-88 6501492 MK 85050	<p>J5</p>  <p>1.9 Diesel 07/87- 1905 cc - 70 HP - 51 kW Mot/Eng: XUD9A ch.no. J0422601- Type/Typ: 280B82-260C62 TSN: 012-683</p>
				<p>7301519 PE61104</p>
1703-07 6201487	1721-20 610888	1725-66 610889 MK 85679	1725-66 N.D.	<p>J5</p>  <p>2.5 Diesel 11/81-03/82 2498 cc - 74 HP - 54 kW Mot/Eng: CRD93 Type/Typ: 280-280P TSN: 008-009-459-474-685-686</p>
				<p>7301519 PE61103</p>
1703-07 6201487	1721-20 610888	1725-66 610889 MK 85679	1725-88 6501492 MK 85050	<p>J5</p>  <p>- ChassisCabin 2.5 Diesel 04/82- 2498 cc - 74 HP - 54 kW Mot/Eng: CRD93 Type/Typ: 280-280P TSN: 008-009-459-474-685-686</p>
				<p>7301518 PE20021</p>
1704-48 N.D.	95604311 N.D.	1704-49 6114224	1731-01 613225	<p>J5</p>  <p>2.5 TD 06/88-05/90 2498 cc - 95 HP - 70 kW Mot/Eng: CRD93LS ch.no. J0422601-S757239 Type/Typ: 280B92/C92/G92/H92/K92/L92 TSN: 015-686</p>
				<p>7314227 PE61105</p>
1704-75 N.D.	1731-01 613225	1726-26 613226 MK 85678		<p>J5</p>  <p>2.5 TD 06/90-12/94 2498 cc - 95 HP - 70 kW Mot/Eng: CRD93LS ch.no. S757240- Type/Typ: 280-290 TSN: 015-021-686</p>
				<p>7314227 PE61107</p>

Los nombres y números de primer equipo se utilizan solamente como referencia

● En desarrollo

IMPORTANTE:

Al pedir sistemas de escape, rogamos completen la referencia comenzando por 'MFO.' (ejemplo: 381394 → MFO.381394)

Pour commander echappement, nous vous prions de compléter la référence en commençant par MFO..

When ordering exhaust, please complete the reference by beginning with MFO..

ESCAPE / ECHAPPEMENT / EXHAUST

Fonos

Peugeot

J7

Bus

1.6 Diesel, 2.0 Diesel

10/67-09/70

1618, 1948 cc - 61, 72 HP - 45, 53 kW

(A) Diesel

(B) Diesel

1701-62
N.D.(A)

1724-92
615366



PE80403

J7

10/72-09/77

(A) -09/76

N.D.(B)
1701-60

1701-79
N.D.(A)

1724-92
615366



PE80404

J7, J9

incl. Diesel

10/77-07/82

1971, 2304 cc - 69, 77 HP - 51, 57 kW

J9: 09/79-

ch.no. -4080000

1703-16
6601365

1724-92
615366

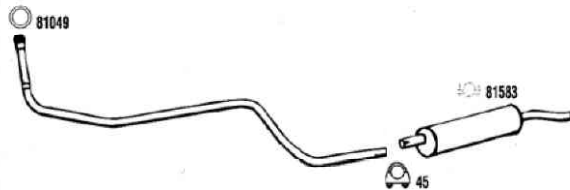

PE80401

J9

08/82-07/86

1971, 2499 cc - 73, 77 HP - 54, 57 kW

Mot/Eng: XD3P, XN1P

ch.no. 4080001-4161000

1703-16
6601365

1724-10
615595

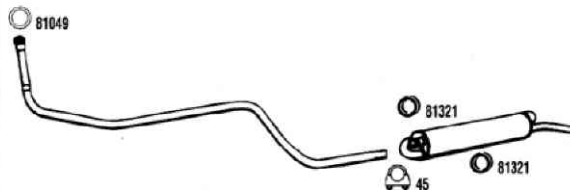

PE20022

J9

07/86-10/87

ch.no. 4161001-

1704-07
6612480

1726-10
615381
MK 85006



7308592

PE80406

J9

10/87-94

1971 cc - 75 HP - 52 kW

Mot/Eng: XN1P

Type/Typ: 888.....

1704-50
6614228

1726-10
615381
MK 85006

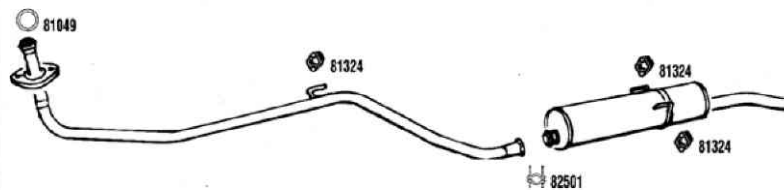

7312880

PE80407

● En desarrollo

Los nombres y números de primer equipo se utilizan solamente como referencia

IMPORTANTE:

Al pedir sistemas de escape, rogamos completen la referencia comenzando por 'MFO.' (ejemplo: 381394 → MFO.381394)

Pour commander echappement, nous vous prions de compléter la référence en commençant par MFO..

When ordering exhaust, please complete the reference by beginning with MFO..

1704-50 6614228	1726-10 615381 MK 85006
--------------------	-------------------------------

J9
2.3 Diesel, 2.5 Diesel
10/87-94
2304, 2498 cc
Mot/Eng: XN2P, XN3P
Type/Typ: 888.....

PE80409

1705 A8 6221807 MK 85288	1731 21 9220096CAT MK 21646	1717 74 613866 MK 85405	1726 N5 613993 MK 85016
--------------------------------	-----------------------------------	-------------------------------	-------------------------------

Partner , Ranch
1.1
06/96-
1124 cc - 60 HP - 44 kW
Mot/Eng: HDZ (TU1M)
Type/Typ: 5

PEW11030 **CAT**

1731P1 N.D.CAT	1717 L9 613498(A)	1726 N5 613993(A) MK 85016
-------------------	----------------------	----------------------------------

Partner , Ranch
1.1 i
06/00-
1124 cc - 60 HP - 44 kW
Mot/Eng: HFX (TU1JP)
To:(A) -12/02
From:(B) 12/02-

PEW11031 **CAT**

1705 C0 6221811 MK 85288	1731 21 9220096CAT MK 21646	1717 74 613866 MK 85405	1726 N5 613993 MK 85016
--------------------------------	-----------------------------------	-------------------------------	-------------------------------

Partner , Ranch
1.4
06/96-10/97
1360 cc - 75 HP - 55 kW
Mot/Eng: KFX (TU3JP)
Type/Typ: 5F
Emission: Euro 96

PEW11032 **CAT**

1705 V8 6221808 MK 85288	1731 95 9220255CAT MK 87173	1717 74 613866 MK 85405	1726 N5 613993 MK 85016
--------------------------------	-----------------------------------	-------------------------------	-------------------------------

Partner , Ranch
1.4
10/97-12/02
1360 cc - 75 HP - 55 kW
Mot/Eng: KFX (TU3JP)
Type/Typ: 5
Emission: Euro 96

PEW11033 **CAT**

1705 48 313110(A) MK 85288	171725 6221858(A) MK 85451	1717 74 613866 MK 85405	1726 N5 613993 MK 85016
----------------------------------	----------------------------------	-------------------------------	-------------------------------

Partner , Ranch
1.4
06/96-12/02
1360 cc - 75 HP - 55 kW
Mot/Eng: K5A (TU3.2)
Type/Typ: 5
To:(A) -09/97
From:(B) 09/97-

PEW11034

Los nombres y números de primer equipo se utilizan solamente como referencia

● En desarrollo

IMPORTANTE:

Al pedir sistemas de escape, rogamos completen la referencia comenzando por 'MFO.' (ejemplo: 381394 → MFO.381394)
Pour commander echappement, nous vous prions de compléter la référence en commençant par MFO..
When ordering exhaust, please complete the reference by beginning with MFO..

ESCAPE / ECHAPPEMENT / EXHAUST

Fonos

MOTOR / MOTEUR / ENGINE

Peugeot

Partner , Ranch

1.4
01/00-12/02
1360 cc - 75 HP - 55 kW
Mot/Eng: K6C (TU3JP)
Type/Typ: 5

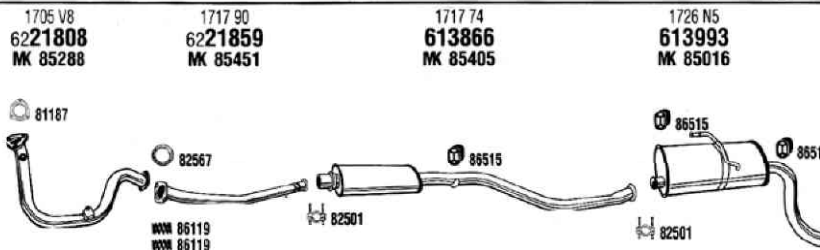

PEW11035

Partner , Ranch

1.4
06/96-12/02
1360 cc - 75 HP - 55 kW
Mot/Eng: KFX (TU3JP)
Type/Typ: 5
Emission: Euro 2000

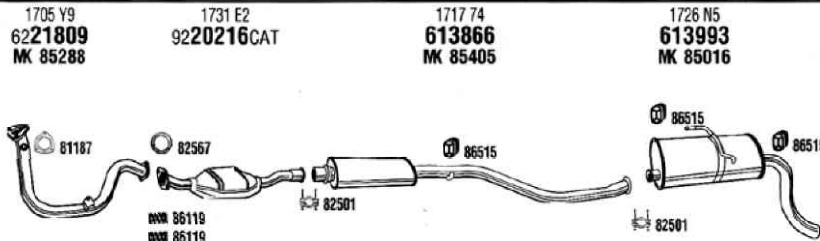

PEW11036 CAT

Partner , Ranch

1.4
06/96-12/02
1360 cc - 75 HP - 55 kW
Mot/Eng: KFW (TU3JP)
Type/Typ: 5F

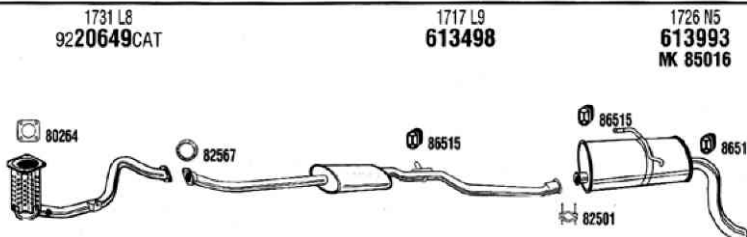

PEW11037 CAT

Partner , Ranch

1.4
12/02-
1360 cc - 75 HP - 55 kW
Mot/Eng: KFW (TU3JP)
Type/Typ: 5F

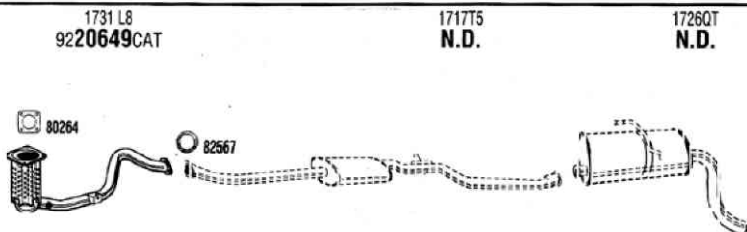

PEW11038 CAT

Partner , Ranch

1.6 16v
07/01-
1587 cc - 109 HP - 80 kW
Mot/Eng: NFU (TU5JP4)
Type/Typ: 5F
To: (A) -11/02
From: (B) 12/02-

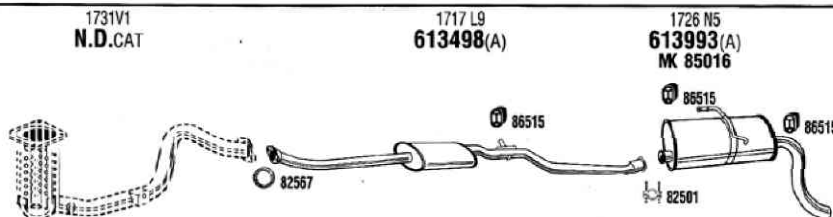

PEW11039 CAT

Partner , Ranch

1.8 Diesel
06/96-
1769 cc - 58 HP - 43 kW
Mot/Eng: AGA (XUD7)
Type/Typ: 5

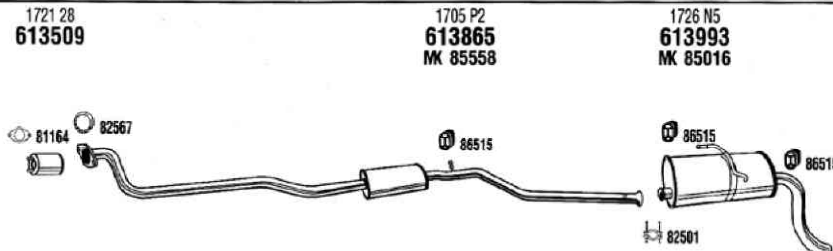

PEW11041

● En desarrollo

Los nombres y números de primer equipo se utilizan solamente como referencia

IMPORTANTE:

Al pedir sistemas de escape, rogamos completen la referencia comenzando por 'MFO.' (ejemplo: 381394 → MFO.381394)
Pour commander echappement, nous vous prions de compléter la référence en commençant par MFO..
When ordering exhaust, please complete the reference by beginning with MFO..

<p>1705 T8 9320297CAT MK 21826</p> <p>82563 86515 86515 82501 86519 86519</p>	<p>1717 74 613866 MK 85405</p> <p>86515 82501</p>	<p>1726 N5 613993 MK 85016</p> <p>86515 86515 82501</p>
---	---	---

Partner , Ranch
1.8
05/97-
1761 cc - 90 HP - 66 kW
Mot/Eng: LFX (XU7JB)
Type/Typ: 5F

PEW11040 **CAT**

<p>1721 28 613509</p> <p>81164 82567 86515 82501</p>	<p>1705 P2 613865 MK 85558</p> <p>86515 82501</p>	<p>1726 N5 613993 MK 85016</p> <p>86515 86515 82501</p>
--	---	---

Partner , Ranch
1.9 Diesel
06/96-
1905 cc - 69 HP - 51 kW
Mot/Eng: D9B (XUD9A)
Type/Typ: 5

PEW11043

<p>1705 P4 9820309CAT MK 87234</p> <p>82567 86515 48 86515</p>	<p>1726 N5 613993 MK 85016</p> <p>86515 82501 82501</p>	<p>6607581(A) 1705P4SP22</p> <p>86515 82501</p>
--	---	---

Partner , Ranch
1.9 Diesel
06/96-
1905 cc - 69 HP - 51 kW
Mot/Eng: D9B,DJY (XUD9A)
Type/Typ: 5F
(A) repair pipe

PEW11042 **CAT**

<p>1705 AC 9820316CAT MK 87233</p> <p>80137 86515 48 86515</p>	<p>1726 N5 613993 MK 85016</p> <p>86515 82501 82501</p>	<p>6607581(A) 1705P4SP22</p> <p>86515 82501</p>
--	---	---

Partner , Ranch
1.9 Diesel
12/98-
1868 cc - 69 HP - 51 kW
Mot/Eng: WJZ (DW8)
Type/Typ: 5F
(A) repair pipe

PEW11044 **CAT**

<p>1705PS 613842(A)</p> <p>86019 86515 48 86515</p>	<p>1731 N8 9220616CAT</p> <p>86515 86515 82501 82501</p>	<p>1726 N5 613993 MK 85016</p> <p>86515 86515 82501</p>
---	--	---

Partner , Ranch
1.9 Diesel
12/98-12/02
1868 cc - 69 HP - 51 kW
Mot/Eng: WJY (DW8B)
Type/Typ: 5F
To: (A) - 11/01
From: (B) 11/01-
(C) repair pipe

PEW11045 **CAT**

<p>1705QV N.D.</p> <p>86019</p>	<p>1731Y1 9620655CAT</p> <p>86515 82501</p>	<p>1726QP N.D.</p> <p>82501</p>
-------------------------------------	---	-------------------------------------

Partner , Ranch
1.9 Diesel
12/02-
1868 cc - 69 HP - 51 kW
Mot/Eng: WJY (DW8B)
Type/Typ: 5F

PEW11046 **CAT**

Los nombres y números de primer equipo se utilizan solamente como referencia

● En desarrollo

IMPORTANTE:

Al pedir sistemas de escape, rogamos completen la referencia comenzando por 'MFO.' (ejemplo: 381394 → MFO.381394)
Pour commander echappement, nous vous prions de compléter la référence en commençant par MFO..
When ordering exhaust, please complete the reference by beginning with MFO..

ESCAPE / ECHAPPEMENT / EXHAUST

Fonos

Peugeot

Partner , Ranch

2.0 HDI
02/00-
 1997 cc - 90 HP - 66 kW
 Mot/Eng: RHY (DW10TD)
 Type/Typ: 5F
 Emission:(A) Euro II
 Emission:(B) Euro III
 To:(C) -11/02
 From:(D) 11/02-

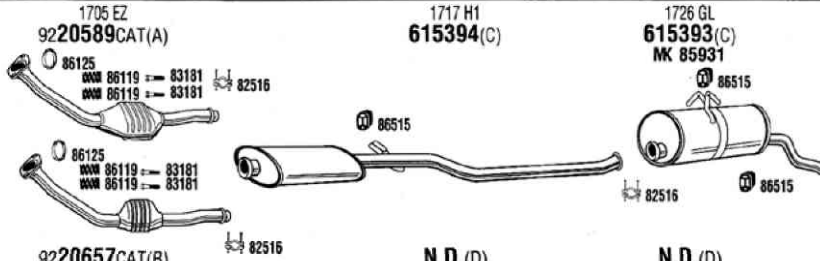

PEW11047 **CAT**

104

L-GL
 1.0
08/72-06/74
 954, 1124 cc - 45 HP - 33 kW
 Mot/Eng: XV3
 ch.no. -5159802
 Type/Typ: 104A01
 TSN: 370-372

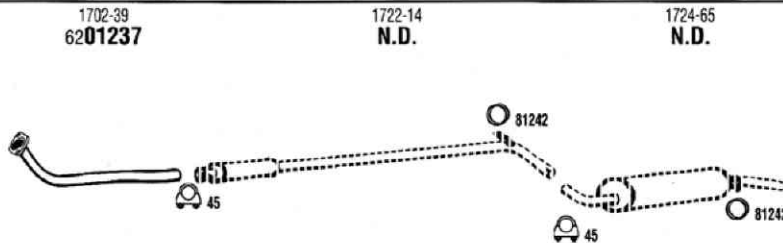

PE10001

104

L-GL-SL-GLS
 1.0
08/72-09/78
 954 cc - 45 HP - 33 kW
 Mot/Eng: XV3
 L-GL: ch.no. 5159803-5688000
 SL-GLS: ch.no. -7193000
 Type/Typ: 104A01-104A11-104543
 TSN: 372-421

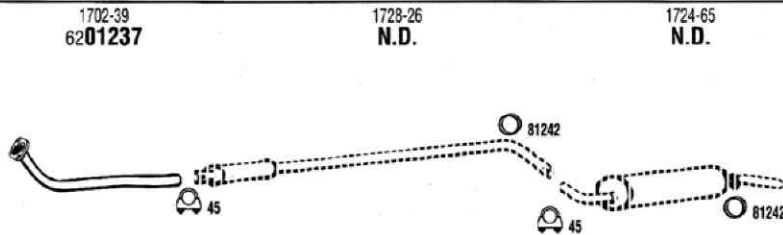

PE10002

104

GL-GR-SR
 1.0
10/78-08/82
 954 cc - 45 HP - 33 kW
 Mot/Eng: XV3
 ch.no. 5688001-6133005
 Type/Typ: 104A01/A11/A21/A41
 TSN: 372-421

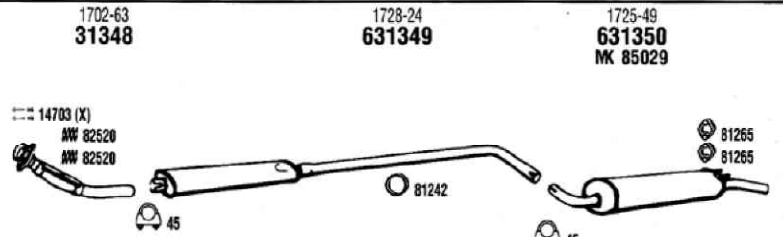

PE10003

104

ZL-ZA Coupé
 1.0
08/72-09/75
 954 cc - 45 HP - 33 kW
 Mot/Eng: XV3
 Type/Typ: 104A01

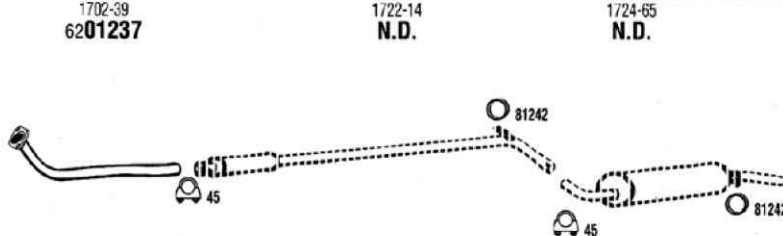

PE10055

104

ZL-ZA Coupé
 1.0
10/75-09/78
 954 cc - 45 HP - 33 kW
 Mot/Eng: XV3
 ch.no. -5684246
 Type/Typ: 104C01
 TSN: 425

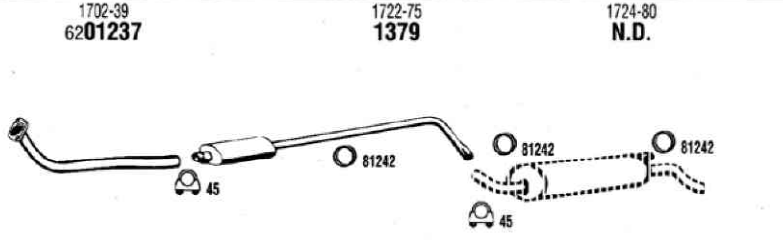

PE10023

● En desarrollo

Los nombres y números de primer equipo se utilizan solamente como referencia

IMPORTANTE:

Al pedir sistemas de escape, rogamos completen la referencia comenzando por 'MFO.' (ejemplo: 381394 → MFO.381394)
 Pour commander echappement, nous vous prions de compléter la référence en commençant par MFO..
 When ordering exhaust, please complete the reference by beginning with MFO..

1702-64 N.D.	1722-75 1379	1725-58 631232 MK 85029		104 ZA-ZL Coupé 1.0 10/78-08/82 954 cc - 45 HP - 33 kW Mot/Eng: XV3 ch.no. 5684247-6133005 Type/Typ: 104C11-104S01 TSN: 425
1702-90 1378	1722-75 1379	1725-58 631232 MK 85029		104 ZA-ZR-ZL Coupé 1.0 10/79-08/82 954 cc - 50 HP - 37 kW Mot/Eng: XV5 ch.no. -6133005 Type/Typ: 104C11-104S01-104S11 TSN: 426-436
1702-39 6201237	1722-14 N.D.	1724-65 N.D.		104 L-GL 1.1 10/72-06/74 1124 cc - 50 HP - 37 kW Mot/Eng: XW3 ch.no. -5159802 Type/Typ: 104A01
1702-39 6201237	1728-26 N.D.	1724-65 N.D.		104 L-GL-SL-GLS 1.1 08/72-09/78 1124 cc - 50 HP - 37 kW Mot/Eng: XW3 L-GL: ch.no. 5159803-5688000 SL-GL S: ch.no. -7193000 Type/Typ: 104A01-104A11-104543
1702-61 N.D.	1722-62 N.D.	1725-49 631350 MK 85029		104 S-Sundgau 1.1 09/78-09/79 1124 cc - 66 HP - 49 kW Mot/Eng: XW3S Type/Typ: 104A31 TSN: 384
1702-63 31348	1728-24 631349	1725-49 631350 MK 85029		104 GL-GR-SL-GLS 1.1 10/78-08/82 1124 cc - 50 HP - 36 kW Mot/Eng: XW3 ch.no. 5688001-6133005 Type/Typ: 104A01/A11/A21/A41-104543 TSN: 397-422-435

Los nombres y números de primer equipo se utilizan solamente como referencia

● En desarrollo

IMPORTANTE:

Al pedir sistemas de escape, rogamos completen la referencia comenzando por 'MFO.' (ejemplo: 381394 → MFO.381394)

Pour commander echappement, nous vous prions de compléter la référence en commençant par MFO..

When ordering exhaust, please complete the reference by beginning with MFO..

ESCAPE / ECHAPPEMENT / EXHAUST

Peugeot

104
GL-GR-SR-GLS
 1.1
09/82-06/88
 1124 cc - 50 HP - 37 kW
 Mot/Eng: XW7
 ch.no. 6133006-
 Type/Typ: 104A11-104A27-104A11A-104A17
 TSN: 372-421-423

1703-09
6601496

1725-72
615397
 MK 85362



7301517

PE10004
104
Z-ZA-ZR
 1.1
10/79-08/82
 1124 cc - 57 HP - 42 kW
 Mot/Eng: XV8
 ch.no. -6133005
 Type/Typ: 104C11-104S01-104S11
 TSN: 425

1702-90
1378

1722-75
1379

1725-58
631232
 MK 85029

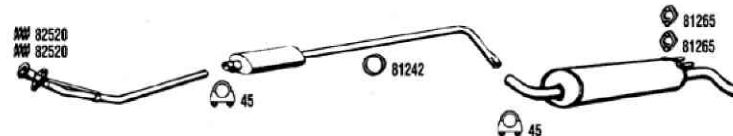

7301129

PE10056
104
Z-ZA-ZR-Style Z
 1.1
09/82-07/88
 1124 cc - 50 HP - 37 kW
 Mot/Eng: XW7
 ch.no. 6133006-
 Type/Typ: 104C11/C11A/C17/S01/S11
 TSN: 436

1703-10
6601475

1725-73
613913
 MK 85362



7301517

PE10031
104
GR-SR
 1.2
10/80-08/84
 1219 cc - 57 HP - 42 kW
 Mot/Eng: XZ5
 Type/Typ: 104543
 TSN: 423

1702-63
31348

1728-24
631349

1725-49
631350
 MK 85029

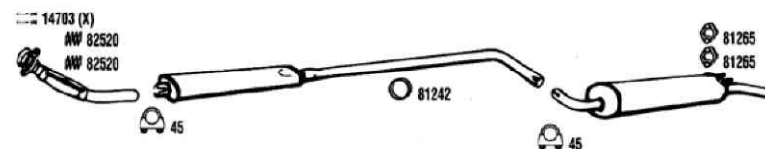

7301129

PE10057
104
S-Sundgau
 1.4
10/79-08/82
 1360 cc - 72 HP - 53 kW
 Mot/Eng: XY6B
 ch.no. -6133005
 Type/Typ: 104A31-104A37
 TSN: 424

1702-63
31348

1728-24
631349

1725-49
631350
 MK 85029

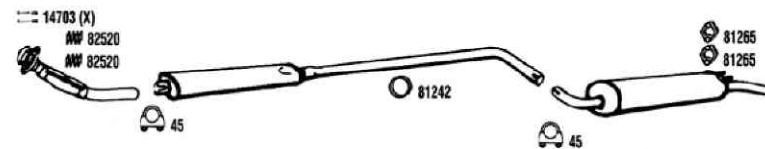

7301129

PE10012
104
ZS Coupé
 1.4
10/79-09/82
 1360 cc - 72 HP - 53 kW
 Mot/Eng: XY6B
 Type/Typ: 104C31-104C37
 TSN: 427

1702-63
31348

1722-90
6401391¹

1724-83
N.D.







7301129

● En desarrollo

Los nombres y números de primer equipo se utilizan solamente como referencia

IMPORTANTE:

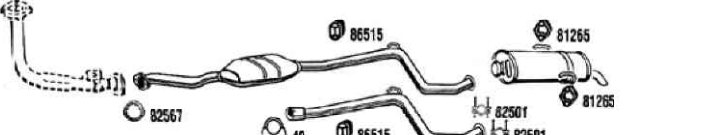
Al pedir sistemas de escape, rogamos completen la referencia comenzando por 'MFO.' (ejemplo: 381394 → MFO.381394)
 Pour commander echappement, nous vous prions de compléter la référence en commençant par MFO..
 When ordering exhaust, please complete the reference by beginning with MFO..

<p>1703-29 N.D.</p> 	<p>1728-14 1234</p>	<p>1725-77 61235(A)</p> <p>5308557(B) 1725-87</p>	<p>104 ZS Coupé 1.4 10/82-07/85 1360 cc - 80 HP - 59 kW Mot/Eng: XY8 (A) ch.no. -6252188 (B) ch.no. 6252189- Type/Typ: 104C37-104C371</p>
<p>1705-16 315123</p> 	<p>1726-97 615124 MK 85047</p>	<p>7317163</p>	<p>106 XN-XR-Kid 1.0 09/91-07/92 954 cc - 45 HP - 33 kW Mot/Eng: TU9 Type/Typ: 1CC1A2-1CH1A1/A2-1AH1A2 Type/Typ: 1AC1A1-1AH3A1/A2-1CC1A1 TSN: 693-700</p>
<p>1705 44 6104064</p> 	<p>1731 52 9719172CAT MK 19240</p> <p>1726 L7 615127 MK 85009</p> <p>6598751(A) 1731-12S</p> <p>6508138(B) 1731 53(RP)</p>	<p>7317172</p>	<p>106 XN-XR-XA-XT--Kid-Zenith 1.0i 09/91-06/95 954 cc - 50 HP - 37 kW Mot/Eng: TU9MZ (CDZ) ch.no. -S51181018 (A) repair pipe dia.42.5mm - (B) repair pipe dia.38.5mm Type/Typ: 1AC1CC1-1CD.Y1/Y2 - TSN: 693-700 λ¹-Exc.Depol 15-04</p>
<p>1705-H1 N.D.</p> 	<p>1731 52 9719172CAT MK 19240</p> <p>1726 L7 615127 MK 85009</p> <p>6598751(A) 1731-12S</p> <p>6508138(B) 1731 53(RP)</p>	<p>7317172</p>	<p>106 XN-XR-XA-Kid-Zenith 1.0i 07/95-06/96 954 cc - 50 HP - 37 kW Mot/Eng: TU9MZ (CDZ) ch.no. S51181019- (A) repair pipe dia.42.5mm - (B) repair pipe dia.38.5mm Type/Typ: 1AC1CCZ1.Z.Y1/Y2 - TSN: 639-700 λ¹-Exc.Depol 15-04</p>
<p>1705 44 6104064</p> 	<p>1731 52 9719172CAT MK 19240</p> <p>1726 L7 615127 MK 85009</p> <p>6598751(A) 1731-12S</p> <p>6504068(B) 1732 12B</p> <p>6508138(C) 1731 53(RP)</p>	<p>7317172</p>	<p>106 SX-XL-XR-XT-XA 1.0i 04/96- 954 cc - 50 HP - 37 kW Mot/Eng: TU9M (A) repair pipe dia.42.5mm - (B) repair pipe dia.38.5mm (C) repair pipe dia.38.5mm Type/Typ: 1ACDZD-1CCDZD-1SCDZD</p>
<p>1705-16 315123</p> 	<p>1726-97 615124 MK 85047</p>	<p>7317163</p>	<p>106 XN-XR-XA-Kid 1.1 09/91-07/92 1124 cc - 60 HP - 44 kW Mot/Eng: TU1M (HDZ) Type/Typ: 1CC1A1/A2-1CH1A1/A2-1AC1A1 Type/Typ: 1AH1A1/1A2/3A2-1SH1A1/A2 TSN: 690-698</p>

Los nombres y números de primer equipo se utilizan solamente como referencia

● En desarrollo

IMPORTANTE:

Al pedir sistemas de escape, rogamos completen la referencia comenzando por 'MFO.' (ejemplo: 381394 → MFO.381394)
 Pour commander echappement, nous vous prions de compléter la référence en commençant par MFO..
 When ordering exhaust, please complete the reference by beginning with MFO..

ESCAPE / ECHAPPEMENT / EXHAUST

Peugeot

Fonos

106
XN-XR-XT-XA
 1.1i
09/91-06/95
 1124 cc - 60 HP - 44 kW
 Mot/Eng: TU1MC
 ch.no. -S51181018
 (A) repair pipe dia.42.5mm - (B) repair pipe dia.38.5mm
 Type/Typ: 1AHDY2/Z1/Z2-1CHDY2/Z1/Z2
 TSN: 690-698
 λ¹-Exc.Depol 15-04
PE10605 CAT

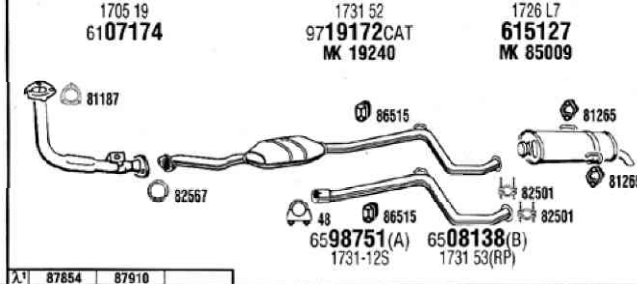

7317172

106
XN-XR
 1.1i
07/92-06/95
 1124 cc - 60 HP - 44 kW
 Mot/Eng: TU1M (HDZ)
 (A) repair pipe dia.42.5mm - (B) repair pipe dia.38.5mm
 Type/Typ: 1AHDY2, 1CHDY2
 TSN: 690-698
 λ¹-Exc.Depol 15-04
PE10629 CAT

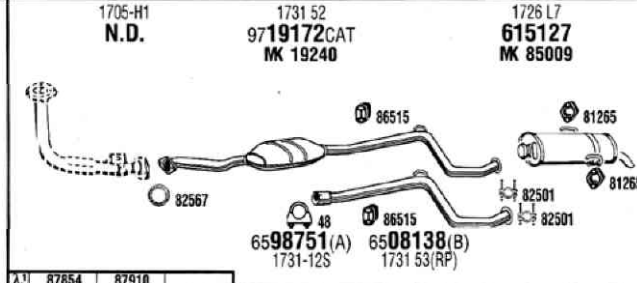

7317172

106
XN-XR-XT-XA
 1.1i
07/95-04/96
 1124 cc - 60 HP - 44 kW
 Mot/Eng: TU1MC
 ch.no. S51181019-
 (A) repair pipe dia.42.5mm - (B) repair pipe dia.38.5mm
 Type/Typ: 1AH,1CH,Z1,Z2 - TSN: 690-698
 λ¹-Exc.Depol 15-04
 λ²-Depol 15-04
PE10626 CAT

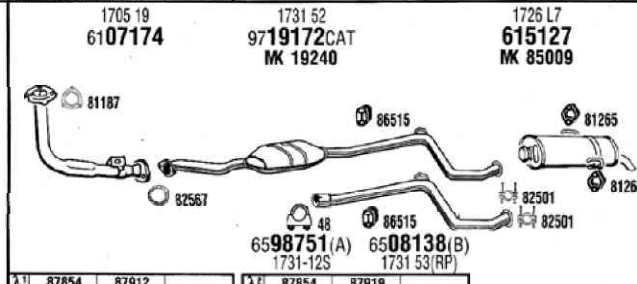

7317172

106
Hatchback
 1.1i
04/96-
 1124 cc - 60 HP - 44 kW
 Mot/Eng: TU1MZ
 (A) repair pipe dia.42.5mm - (B) repair pipe dia.36.5mm
 (C) Depol. CEE 95 L3 (D) Depol. CEE 19-5
 (E) repair pipe diam. 38.5mm
 Type/Typ: 1AH,1CH,1SH - TSN: 690-698-782-822
PE10638 CAT

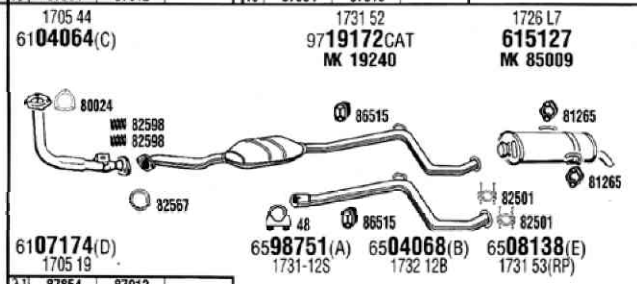

7317172

106
 1.1
07/00-
 1124 cc - 60 HP - 44 kW
 Mot/Eng: TU1JP
 Depol.CEE2000
 Type/Typ: 1AHXF,1CHXF,1SHXF
PE10656 CAT

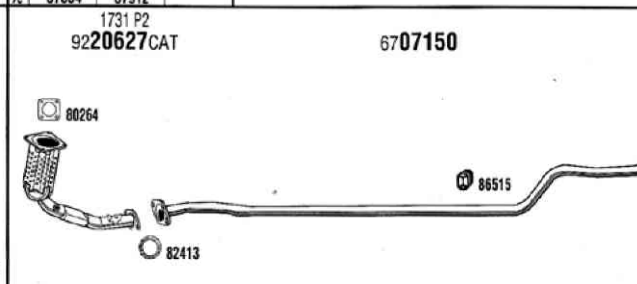

7317172

106
XR-XT
 1.4i
09/91-07/92
 1360 cc - 75 HP - 55 kW
 Mot/Eng: TU32 (K2D)
 Type/Typ: 1CK2D2-1AK2D2
 TSN: 691-693
PE10603

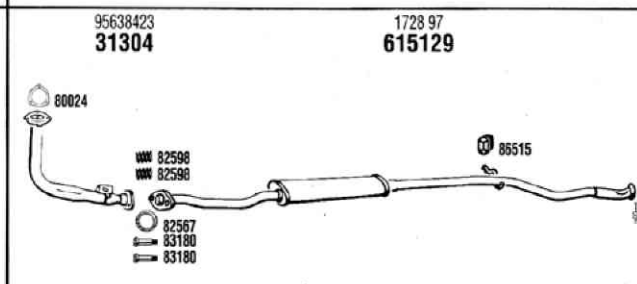

7317167

● En desarrollo

Los nombres y números de primer equipo se utilizan solamente como referencia

IMPORTANTE:

Al pedir sistemas de escape, rogamos completen la referencia comenzando por 'MFO.' (ejemplo: 381394 → MFO.381394)
 Pour commander echappement, nous vous prions de compléter la référence en commençant par MFO..
 When ordering exhaust, please complete the reference by beginning with MFO..

Fonos

Peugeot

1705-18 6117168	1728-98 615134	1726-72 615135 MK 85009
--------------------	-------------------	-------------------------------

7317171

106
XSi
1.4i
09/91-07/92
1360 cc - 100 HP - 74 kW
Mot/Eng: TU3FJ
Type/Typ: 1CK6B2

1705 65 6107172	1731 E3 9219173CAT MK 87216	1717 69 613160 MK 85460	1726 L7 615127 MK 85009
--------------------	-----------------------------------	-------------------------------	-------------------------------

7317173

106
XR-XT-XS
1.4i
09/91-04/96
1360 cc - 75 HP - 55 kW
Mot/Eng: TU3M (KDY)
Type/Typ: 1AKDY2-1AKDY8-1CKDY2-1CKDY8
TSN: 691-699-783
λ¹-09/91->06/95 (Exc. Depol 15-04)
λ²-07/95->04/97

λ ¹ 87854 87910	λ ² 87854 87912		
1705 65 6107172	1731 E3 9219173CAT MK 87216	1717 69 613160 MK 85460	1726 L7 615127 MK 85009

7317173

106
XR-XT-XS-Roland Garros
1.4i
05/93-04/96
1360 cc - 75 HP - 55 kW
Mot/Eng: TU3MC (KDX)
Type/Typ: 1AKDX2-1AKDX8-1CKDX2-1CKDX8
TSN: 691-699
λ¹-05/93->06/95 (Exc. Depol 15-04)
λ²-07/95->04/96 (Exc. Depol 15-04)
λ³-07/95->04/96 (Depol 15-04)

λ ¹ 87854 87910	λ ² 87854 87912	λ ³ 87854 87919	
1705 65 6107172	1731 E3 9219173CAT MK 87216	1717 69 613160 MK 85460	1726 L7 615127 MK 85009

7317173

106
1.4 Autom.
04/96-
1360 cc - 75 HP - 55 kW
Mot/Eng: TU3JP
Depolition restriction : EURO93 and EURO96
Type/Typ: 1AKFXS-1CKFXS
TSN: 692-783
λ¹-Exc. Depol CEE 2000

λ ¹ 87854 87912			
1705 65 6107172	1731 E3 9219173CAT MK 87216	1717 69 613160 MK 85460	1726 L7 615127 MK 85009

7317173

106
1.4 Autom.
03/98-12/99
1360 cc - 75 HP - 55 kW
Mot/Eng: TU3JP
Depolition restriction : EURO93 and EURO96
Type/Typ: 1CKFXL
TSN: 783
λ¹-Exc. Depol CEE 2000

λ ¹ 87854 87912			
1705-25 N.D.	1731 66 9220154CAT MK 87216	1717-35 615138 MK 85460	1726-72 615135 MK 85009

7317175

106
XSi-Le Mans
1.4i
09/91-04/96
1360 cc - 95 HP - 69 kW
Mot/Eng: TU3FJ2
Type/Typ: 1CKFZ2 - TSN: 692
λ¹-09/91->06/95
λ²-07/95->04/95 exc. Depol. 15-04
λ³-07/95->04/95 exc. Depol. 15-04

Los nombres y números de primer equipo se utilizan solamente como referencia

● En desarrollo

IMPORTANTE:

Al pedir sistemas de escape, rogamos completen la referencia comenzando por 'MFO.' (ejemplo: 381394 → MFO.381394)
 Pour commander echappement, nous vous prions de compléter la référence en commençant par MFO..
 When ordering exhaust, please complete the reference by beginning with MFO..

ESCAPE / ECHAPPEMENT / EXHAUST

Peugeot

Fonos

106
1.4i
04/96-
1360 cc - 75 HP - 55 kW
Mot/Eng: TU3JP
DEPOL CEE 2000
RS = W/O chrome tail pipe
Type/Typ: 1AKFXF/1CKFXF
TSN: 285

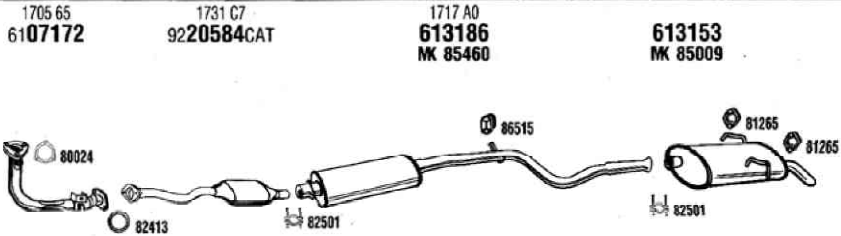

PE10655 **CAT**

106
1.4
07/00-
1360 cc - 75 HP - 55 kW
Mot/Eng: TU3JP
Type/Typ: 1AKPWF, 1CKPWF

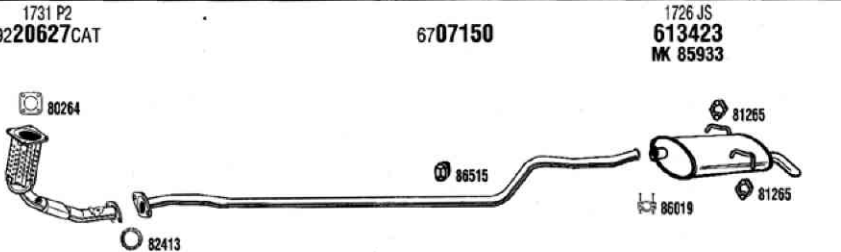

PE10657 **CAT**

106
XS-XT-Griffe
1.6i
06/94-06/96
1587 cc - 88 HP - 65 kW
Mot/Eng: TU5JP (NFZ)
Type/Typ: 1ANFZ2-1CNFZ2 - TSN: 724-726
λ¹=06/94->06/95
λ²=07/95->06/96 exc Depol.15-04
λ³=07/95->06/96 Depol.15-04

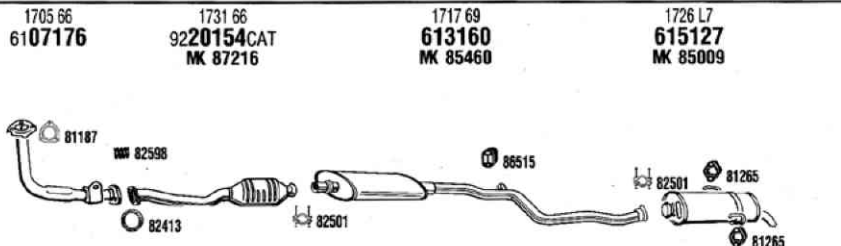

PE10620 **CAT**



106
XS-XT-Gentry
1.6i
09/95-06/96
1587 cc - 88 HP - 65 kW
Mot/Eng: TU5JP (NFZ)
Type/Typ: 1CNFZ2-1ANFZ2
TSN: 724-726
λ¹=Exc. Depol. 15-04
λ²=Depol. 15-04

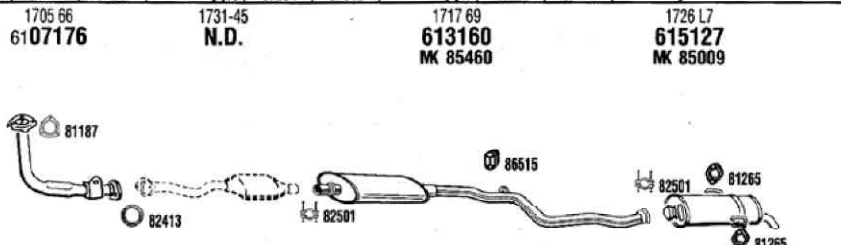

PE10627

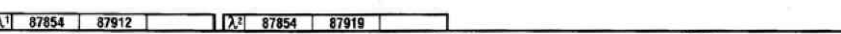

106
XSi
1.6i
07/94-04/96
1587 cc - 103 HP - 76 kW
Mot/Eng: NFY (TU5J2)
Type/Typ: 1CNFY2 - TSN: 735
λ¹=06/94->06/95
λ²=07/95->06/96 exc Depol.15-04
λ³=07/95->06/96 Depol.15-04



PE10632 **CAT**



106
1.6 Rallye
04/96-01/99
1587 cc - 101 HP - 74 kW
Mot/Eng: TU5J2
Type/Typ: 1CNFWE
λ¹=Exc. Depol. CEE 2000

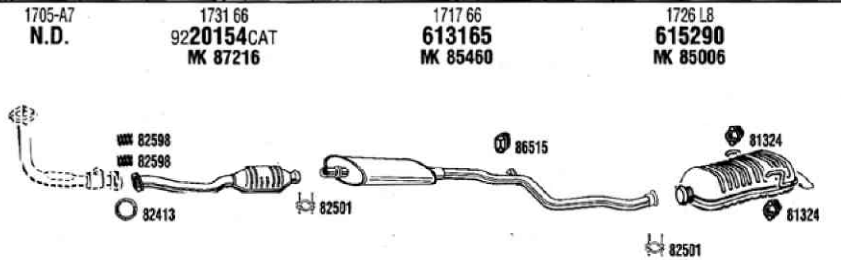

PE10611 **CAT**



● En desarrollo

Los nombres y números de primer equipo se utilizan solamente como referencia

IMPORTANTE:

Al pedir sistemas de escape, rogamos completen la referencia comenzando por 'MFO.' (ejemplo: 381394 → MFO.381394)
Pour commander echappement, nous vous prions de compléter la référence en commençant par MFO..
When ordering exhaust, please complete the reference by beginning with MFO..

1705 66 6107176	1731 66 9220154CAT MK 87216	1717 69 613160 MK 85460	1726 L7 615127 MK 85009
--------------------	-----------------------------------	-------------------------------	-------------------------------

106
1.6
04/96-
1587 cc - 90 HP - 66 kW
Mot/Eng: TU5JP
Type/Typ: 1ANFZE-1ANFZL-1CNFZE-1CNFZL
TSN: 724-726-784
λ¹-Exc: Depol CEE 2000

1705 L5 N.D.	1731 66 9220154CAT(A) MK 87216	1717 66 613165 MK 85460	1726 L8 615290 MK 85006
-----------------	--------------------------------------	-------------------------------	-------------------------------

N.D.CAT(B)
1731 G5

106
1.6 16v
04/96-
1587 cc - 118 HP - 87 kW
Mot/Eng: TU5J4
(A) Depol. CEE 95 (L3)
(B) Depol. CEE 2000 (D3)
Type/Typ: 1CNFXZ
λ¹-Depol:EURO3/CEE95/EURO96

1705 K0 N.D.	1731 P3 9220674CAT	1717 N1 613424	1726 L8 615290 MK 85006
-----------------	-----------------------	-------------------	-------------------------------

106
1.6i 16v
09/00-
1587 cc - 120 HP - 88 kW
Mot/Eng: TU5JP4
Depol. CEE 2000 (L4)
Type/Typ: S6

1705-37 31371	1717-36 615154	1726 L7 615127 MK 85009
------------------	-------------------	-------------------------------

106
XND-XRD-XTD-XAD-XRAD
1.4 Diesel
08/92-06/96
1360 cc - 50 HP - 37 kW
Mot/Eng: TUD3 (K9B)
Type/Typ: 1SK9B1/B2-1AK9B1/B2-1CK9B2
TSN: 694-701

1705-37 31371	1731-16 N.D.CAT	1717 69 613160 MK 85460	1726 L7 615127 MK 85009
------------------	--------------------	-------------------------------	-------------------------------

106
XND-XRD
1.4 Diesel
08/92-06/96
1360 cc - 50 HP - 37 kW
Mot/Eng: TUD3 (K9Y)
Type/Typ: 1C1A-1CK9Y
TSN: 694-701

1705 93 6205322	1728 97 615129	1726 L7 615127 MK 85009
--------------------	-------------------	-------------------------------

106
XND - XRD - XTD
1.5 Diesel
07/94-
1527 cc - 58 HP - 42 kW
Mot/Eng: TUD5
Type/Typ: 1AVJY2-1AVJZ2 (5-)
Type/Typ: 1CVJY2-1CVJZ2 (3-)

Los nombres y números de primer equipo se utilizan solamente como referencia

● En desarrollo

IMPORTANTE:

Al pedir sistemas de escape, rogamos completen la referencia comenzando por 'MFO.' (ejemplo: 381394 → MFO.381394)
Pour commander echappement, nous vous prions de compléter la référence en commençant par MFO..
When ordering exhaust, please complete the reference by beginning with MFO..

ESCAPE / ECHAPPEMENT / EXHAUST

Peugeot

Fonos

106
XND - XRD - XTD
 1.5 Diesel
07/94-
 1527 cc - 55 HP - 40 kW
 Mot/Eng: TUD5
 TSN: 742-743

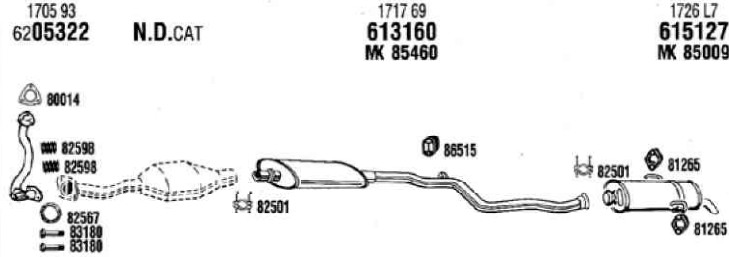

7317173

PE10634 **CAT**

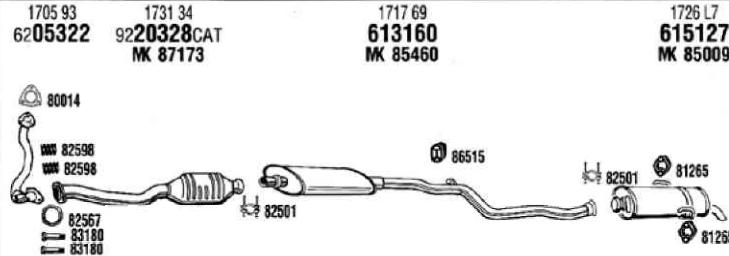

106
 1.5 Diesel
04/96-11/99
 1527 cc - 57 HP - 42 kW
 Mot/Eng: TUD5
 Type/Typ: 1AVJYE-1CVJYE
 TSN: 742-743-787

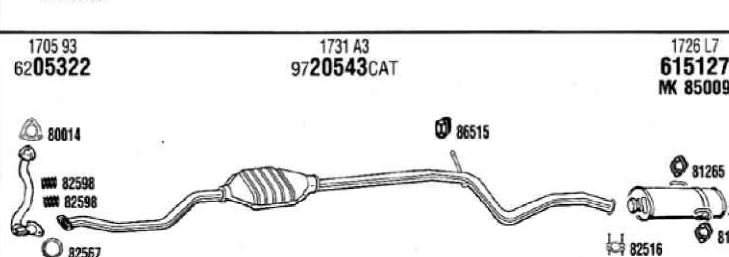

PE10635 **CAT**

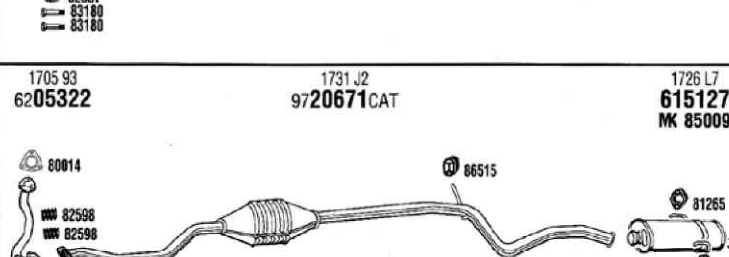

106
 1.5 Diesel
11/99-07/03
 1527 cc - 57 HP - 42 kW
 Mot/Eng: TUD5
 Type/Typ: 1AV,1CV,1SV
Emission EURO II

PE10658 **CAT**

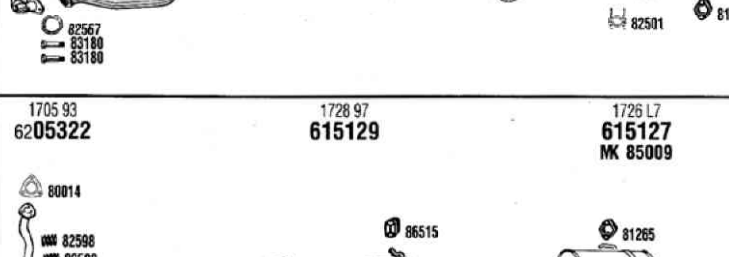

106
 1.5 Diesel
01/99-07/03
 1527 cc - 57 HP - 42 kW
 Mot/Eng: TUD5
 Type/Typ: 1AV,1CV,1SV
Emission EURO III

PE10659 **CAT**

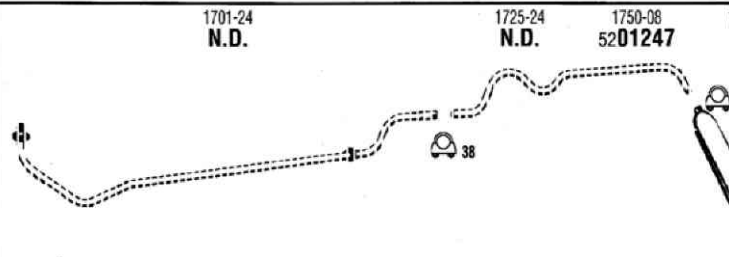

203
Cabrio - Coupé
 1.3
01/48-12/59
 1275 cc - 42, 45 HP - 31, 33 kW

PE20103

● En desarrollo

Los nombres y números de primer equipo se utilizan solamente como referencia

IMPORTANTE:

Al pedir sistemas de escape, rogamos completen la referencia comenzando por 'MFO.' (ejemplo: 381394 → MFO.381394)
 Pour commander echappement, nous vous prions de compléter la référence en commençant par MFO..
 When ordering exhaust, please complete the reference by beginning with MFO..

Fonos

Peugeot

1720-55 N.D.	1701-77 6701256 ¹ (A)	1724-54 615260	204 Cabrio - Coupé 1.1 01/69-12/77 1129 cc - 50 HP - 37 kW Mot/Eng: XK4 (A) -270 mm TSN: 344
			PE20117
1720-55 N.D.	1701-77 6701256 ¹	1724-54 615260	204 Fourgonette 1.1 Diesel, 1.4 Diesel 01/69-09/72 1129, 1357 cc - 50, 41 HP - 37, 30 kW Mot/Eng: XK4-XL4 Type/Typ: U444 TSN: 341
			PE20112
1720-55 N.D.	1701-81 N.D.	1724-54 615260	204 Fourgonette 1.1 Diesel, 1.4 Diesel 10/72-12/77 1129, 1357 cc - 50, 41 HP - 37, 30 kW Mot/Eng: XK4-XL4 Type/Typ: U444 TSN: 341
			PE20113
1720-55 N.D.	1701-77 6701256 ¹	1724-54 615260	204 1.1 Diesel, 1.4 Diesel 01/69-09/72 1129, 1357 cc - 50, 41 HP - 37, 30 kW Mot/Eng: XK4-XL4 Type/Typ: U444 TSN: 340
			PE20108
1720-55 N.D.	1701-81 N.D.	1724-54 615260	204 1.1 Diesel, 1.4 Diesel 10/72-12/77 1129, 1357 cc - 50, 41 HP - 37, 30 kW Mot/Eng: XK4-XL4 Type/Typ: U444 TSN: 340
			PE20109
	1703-31 6701501	1726X2 615623 NK 85831	205 L-GL-GE-XE-XL-XR-XA 1.0 02/83-09/86 954 cc - 45 HP - 33 kW Mot/Eng: XV8 ch.no. -7378594 Type/Typ: 741A01/07/37-741Z01/07 TSN: 461-479
			PE20602

Los nombres y números de primer equipo se utilizan solamente como referencia

● En desarrollo

IMPORTANTE:

Al pedir sistemas de escape, rogamos completen la referencia comenzando por 'MFO.' (ejemplo: 381394 → MFO.381394)

Pour commander echappement, nous vous prions de compléter la référence en commençant par MFO..

When ordering exhaust, please complete the reference by beginning with MFO..

ESCAPE / ECHAPPEMENT / EXHAUST

MOTOR / MOTEUR / ENGINE

Peugeot

Fonos

205
L-GE-GL-GR-XE-XL-XR-Junior
 1.0
10/86-06/87
 954 cc - 45 HP - 33 kW
 Mot/Eng: XV8
 ch.no. 7378595-7900000
 (A)  
 Type/Typ: 741A01/A07-741C01/07
 TSN: 461-479

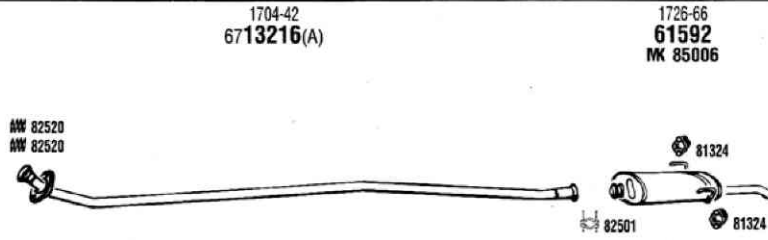

205
GL-XE-XL-XR-Junior
 1.0
07/87-06/92
 954, 1124 cc - 45, 49 HP - 33, 36 kW
 Mot/Eng: TU9
 ch.no. 7900001-
 Type/Typ: 20AC11/12-20CC11-20CH11-20SC11
 TSN: 250, 258, 695, 696

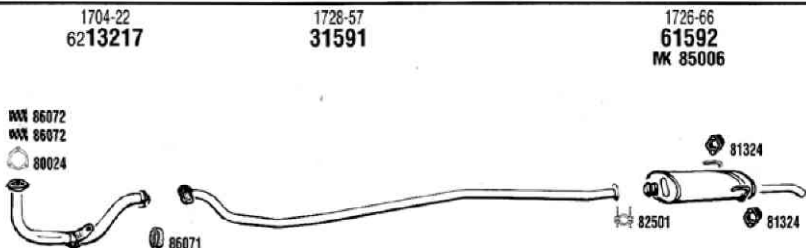

205
Junior-Look
 1.0
07/92-
 954 cc - 50 HP - 37 kW
 Mot/Eng: TU9M
 Type/Typ: 20ACD1/D2-20CCD1/D2

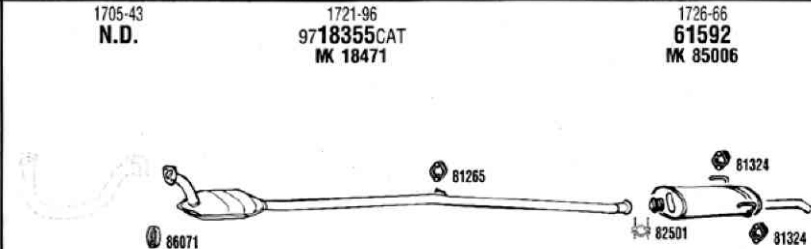

205
GL-GE-GR-XE-XL-XR-XA
 1.1
02/83-07/85
 1124 cc - 50 HP - 37 kW
 Mot/Eng: XW7
 ch.no. -5828776
 Type/Typ: 741A11/A17/C11/C17/S11/S17
 TSN: 462-480

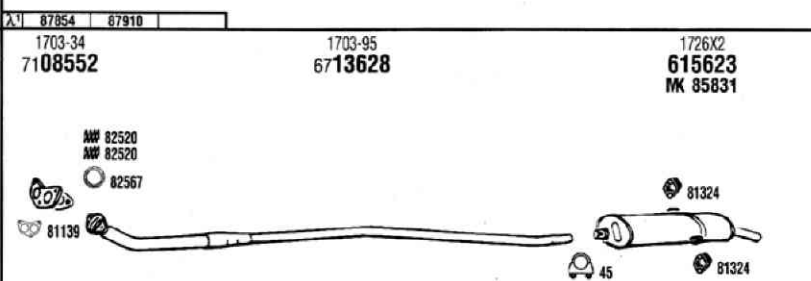

205 
GL-GR-SR
 1.1
07/85-07/87
 1118 cc - 55 HP - 40 kW
 Mot/Eng: E1

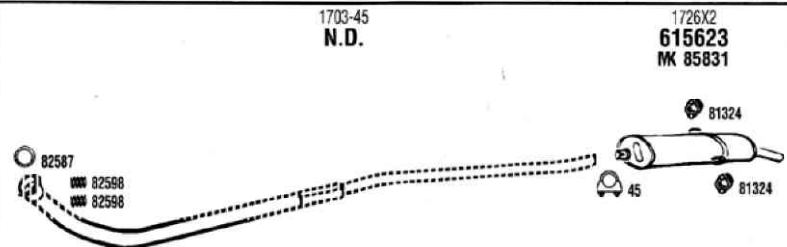

205
XA-XRA
 1.1
07/87-07/88
 1118 cc - 50, 55 HP - 36, 41 kW
 Mot/Eng: E1
 ch.no. 7900001-
 Type/Typ: 20SE11-20SE12-20SG12
 TSN: 250-258

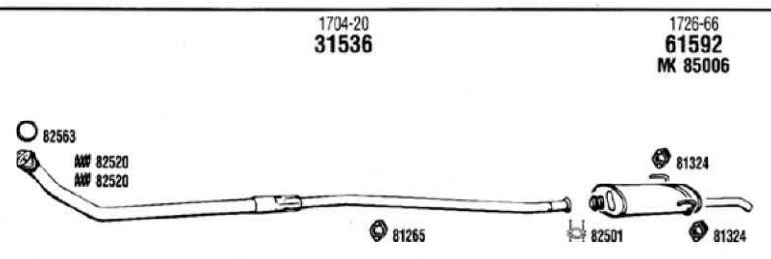

● En desarrollo

Los nombres y números de primer equipo se utilizan solamente como referencia

IMPORTANTE:

Al pedir sistemas de escape, rogamos completen la referencia comenzando por 'MFO.' (ejemplo: 381394 → MFO.381394)
 Pour commander echappement, nous vous prions de compléter la référence en commençant par MFO..
 When ordering exhaust, please complete the reference by beginning with MFO..

Fonos

Peugeot

<p>1703-52 6708530</p>	<p>1726X2 615623 MK 85831</p>	<p>205 L-GL-GE-GR-XE-XR-XA-XL 1.1 08/85-09/86 1124 cc - 50 HP - 37 kW Mot/Eng: XW7 ch.no. 5828777-7378594 Type/Typ: 741A11/A17/C11/C17/S11/S17 TSN: 462-480</p> <p>7313631 PE20613</p>
<p>1704-41 6713221(A)</p>	<p>1726-66 61592 MK 85006</p>	<p>205 GE-GL-GR-XE-XL-XR-XA 1.1 10/86-06/87 1124 cc - 50 HP - 37 kW Mot/Eng: XW7 ch.no. 7378595-7900000 (A) Type/Typ: 741A11/A17/C11/C17/S11/S17 TSN: 462-480</p> <p>7313565 PE20047</p>
<p>1703-34 7108552</p>	<p>1726-66 61592 MK 85006</p>	<p>205 XE-XL-XR-XA 1.1 10/86-12/90 1124 cc - 50 HP - 37 kW Mot/Eng: XW7 ch.no. 7378595- Type/Typ: 741A11/A17/C11/C17/S11/S17</p> <p>7317152 PE20092</p>
<p>1704-22 6213217</p>	<p>1726-66 61592 MK 85006</p>	<p>205 GR-GL-GE-XL-XR-XE 1.1 07/87-07/92 1124 cc - 55 HP - 40 kW Mot/Eng: TU1 ch no. 7900001- Type/Typ: 20AH11/12-20CH11/12-20SH11/12 TSN: 201-204-280-287</p> <p>7313564 PE20048</p>
<p>1705 10 6207180</p>	<p>1726-66 61592 MK 85006</p>	<p>205 XA-XE-XL-XR-CJ-GE + Cabrio 1.1 11/89-11/97 1124 cc - 60 HP - 44 kW Mot/Eng: TU1M (A) repair pipe Cat Type/Typ: 20AHD2-20CHD2-20DHD2-20SHD2 TSN: 633-634-635</p> <p>7318025 PE20118 CAT</p>
<p>1703-52 6708530</p>	<p>1726X2 615623 MK 85831</p>	<p>205 XA-Multi 1.1 07/85-09/86 1124 cc - 50 HP - 37 kW Mot/Eng: XW7 ch no. -7378594</p> <p>7313631 PE20121</p>

Los nombres y números de primer equipo se utilizan solamente como referencia

● En desarrollo

IMPORTANTE:

Al pedir sistemas de escape, rogamos completen la referencia comenzando por 'MFO.' (ejemplo: 381394 → MFO.381394)

Pour commander echappement, nous vous prions de compléter la référence en commençant par MFO..

When ordering exhaust, please complete the reference by beginning with MFO..

ESCAPE / ECHAPPEMENT / EXHAUST

Peugeot

Fonos

205
XA-Multi 
 1.1
10/86-
 1124 cc - 50 HP - 37 kW
 Mot/Eng: XW7
 ch.no. 7378595-

1704-41
 6713221

1726-66
61592
 MK 85006



 7313565

PE20511
205 
XL-XR-GT
 1.3
07/85-07/87
 1294 cc - 65 HP - 48 kW
 Mot/Eng: G2
 ch.no. -7900000
 Type/Typ: 20AG12-20CG12-20SG12

1703-45
 N.D.

1726X2
615623
 MK 85831





 7313565

PE20652
205 
XL-XR-GT
 1.3
08/87-12/90
 1294 cc - 65 HP - 48 kW
 Mot/Eng: G1
 ch.no. -7900001-
 Type/Typ: 20AG12-20CG12-20SG12

1704-20
31536

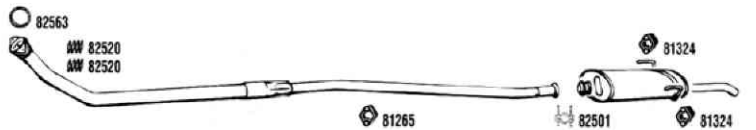
1726-66
61592
 MK 85006





 7312814

PE20615
205
Rallye
 1.3
03/88-09/89
 1294 cc - 103 HP - 76 kW
 Mot/Eng: TU24
 ch.no. -233668275
 Type/Typ: 20CM22

1704-99
 6215497

1728-67
 6714199¹

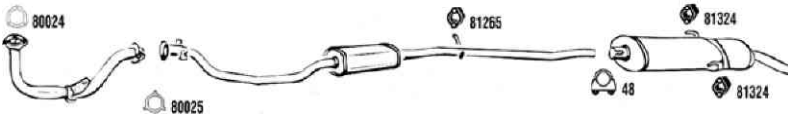
1725-94
61529





 7312814

PE20062
205
Rallye
 1.3
10/89-07/92
 1294 cc - 101 HP - 74 kW
 Mot/Eng: TU2-TU4
 ch.no. 233668276-
 Type/Typ: 20CM22-20AM22

1704-99
 6215497

1728-88
 6715498¹

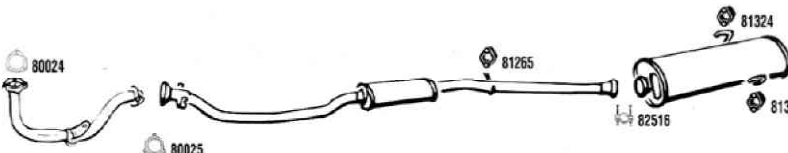
1726-69
615499
 MK 85088



 7314200

PE20071
205
GR-SR-XR-XRA-Lacoste
 1.4
02/83-07/85
 1360 cc - 60 HP - 44 kW
 Mot/Eng: XY7
 ch.no. -5712545
 Type/Typ: 741A41/A47/C41/C47/C57/S41/S47
 TSN: 463-481

1703-34
 7108552

1703-95
 6713628

1726X2
615623
 MK 85831



 7315500

PE20609
 En desarrollo

Los nombres y números de primer equipo se utilizan solamente como referencia

IMPORTANTE:

Al pedir sistemas de escape, rogamos completen la referencia comenzando por 'MFO.' (ejemplo: 381394 → MFO.381394)
 Pour commander echappement, nous vous prions de compléter la référence en commençant par MFO..
 When ordering exhaust, please complete the reference by beginning with MFO..

<p>1703-31 6701501</p> <p>1726X2 615623 MK 85831</p>	<p>205 GR-GT-XR 1.4 02/83-09/86 1360 cc - 60 HP - 44 kW Mot/Eng: XY6B ch.no. -7378594</p>
<p>1703-34 7108552</p> <p>1726X2 615623 MK 85831</p>	<p>205 GT-XT 1.4 02/83-07/84 1360 cc - 80 HP - 59 kW Mot/Eng: XY8 ch.no. -5544755 Type/Typ: 741A57-741C57 TSN: 464</p>
<p>1703-52 6708530</p> <p>1726X2 615623 MK 85831</p>	<p>205 GT-XT-XS-CT 1.4i 08/84-09/86 1360 cc - 80 HP - 59 kW Mot/Eng: XY8 ch.no. 5544756-7378594 Type/Typ: 741A57-741B57-741C57 TSN: 464-482</p>
<p>1703-52 6708530</p> <p>1726X2 615623 MK 85831</p>	<p>205 GL-GR-SR-GE-XA-XR-XRA 1.4 08/85-09/86 1360 cc - 60 HP - 44 kW Mot/Eng: XY7 ch.no. 5712546-7378594 Type/Typ: 741A41/A47/C41/C47/C57/S41/S47 TSN: 463-481</p>
<p>1704-41 6713221</p> <p>1726-66 61592 MK 85006</p>	<p>205 GL-GR-SR-XL-XE-XR 1.4 10/86-06/87 1360 cc - 60 HP - 44 kW Mot/Eng: XY7 ch.no. 7378595-7900000 Type/Typ: 741A47-741C47-741S47 TSN: 251-463</p>
<p>1704-42 6713216</p> <p>1726-66 61592 MK 85006</p>	<p>205 GR-SR-XR-XRA 1.4 10/86-07/88 1360 cc - 72 HP - 53 kW Mot/Eng: XY6B ch.no. 7378595-7900000</p>

Los nombres y números de primer equipo se utilizan solamente como referencia

● En desarrollo

IMPORTANTE:

Al pedir sistemas de escape, rogamos completen la referencia comenzando por 'MFO.' (ejemplo: 381394 → MFO.381394)

Pour commander echappement, nous vous prions de compléter la référence en commençant par MFO..

When ordering exhaust, please complete the reference by beginning with MFO..

ESCAPE / ECHAPPEMENT / EXHAUST

MOTOR / MOTEUR / ENGINE

Peugeot

Fonos

205
GT-XT-XS-CT
 1.4i
10/86-06/87
 1360 cc - 80 HP - 59 kW
 Mot/Eng: XY8
 ch.no. 7378595-7900000
 Type/Typ: 741A57-741B57-741C57
 TSN: 464

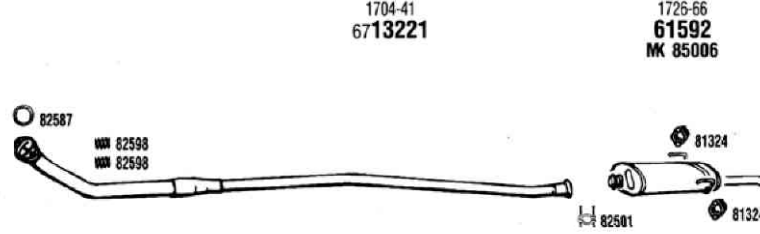

7313565

PE20051
205
GL-GR-SR-XR-XRA-CJ
 1.4
07/87-06/91
 1360 cc - 65, 70 HP - 48, 51 kW
 Mot/Eng: TU3, TU3A
 ch.no. 7900001-
 Type/Typ: 20AK11/AK12/CK12/DK12/SK12
 TSN: 294-295-298

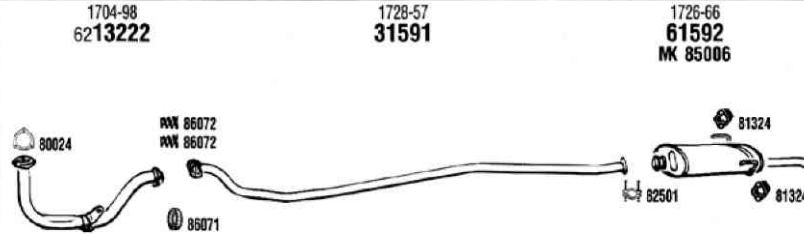

7313564

PE20067
205
XR-Color-Line-Indiana
 1.4
07/91-07/92
 1360 cc - 75 HP - 55 kW
 Mot/Eng: TU3F2
 Type/Typ: 20CK22

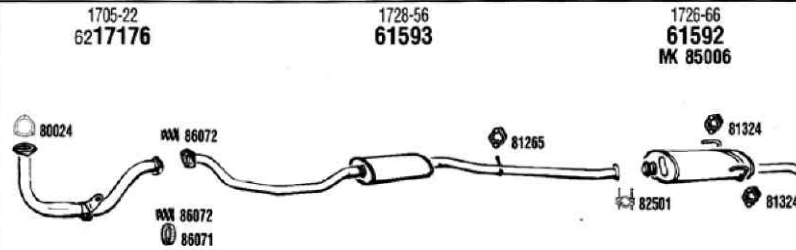

PE20096
205
GT-XT-XS-SR-CT incl. Cabrio
 1.4i
07/87-07/92
 1360 cc - 85 HP - 63 kW
 Mot/Eng: TU3S
 ch.no. 7900001-
 Type/Typ: 20AK22-20CK22-20DK22
 TSN: 296-299

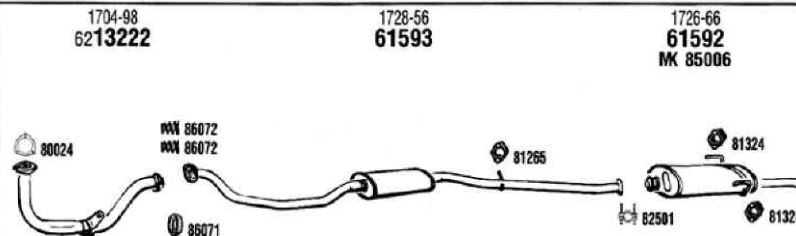

PE20069
205
GL-GR-SR-GT-XL-XR-XS-CJ
 1.4i
08/88-99
 1360 cc - 75 HP - 55 kW
 Mot/Eng: TU3M-TU3MC
 (A) repair pipe Cat
 Type/Typ: 20AK22-20CK22-20DK22
 TSN: 292-293

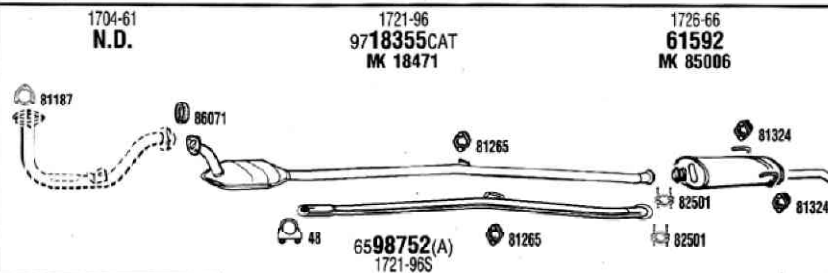

7314641

PE20099 **CAT**
205
XR-XT-GR-GT-Open
 1.6
07/86-07/92
 1580 cc - 80 HP - 59 kW
 Mot/Eng: XU51C
 ch.no. 7330001, 1480001-
 Type/Typ: 741A27/A28/C28-20AB14-20CB14
 TSN: 217-218

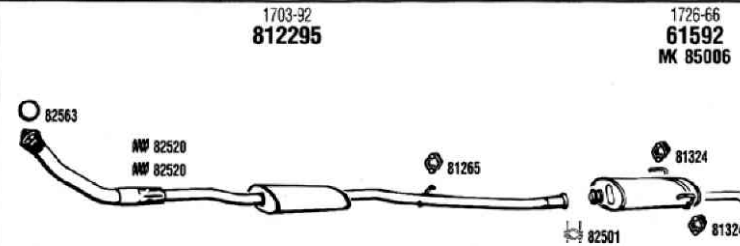

7312814

● En desarrollo

Los nombres y números de primer equipo se utilizan solamente como referencia

IMPORTANTE:

Al pedir sistemas de escape, rogamos completen la referencia comenzando por 'MFO.' (ejemplo: 381394 → MFO.381394)
 Pour commander echappement, nous vous prions de compléter la référence en commençant par MFO..
 When ordering exhaust, please complete the reference by beginning with MFO..

Fonos

Peugeot

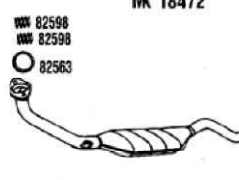
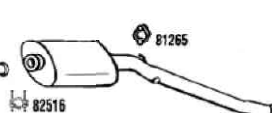
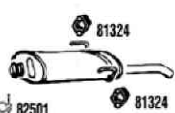
1704-62 9218356CAT MK 18472	1728-47 814640 MK 85737	1726-66 61592 MK 85006
		
87854 87910		82501 81324

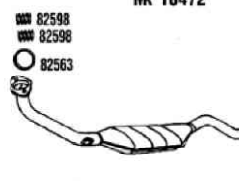
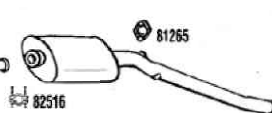
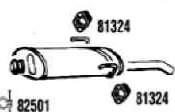

205
GR-GT-XS-XT
1.6i
09/86-06/90
1580 cc - 75 HP - 55 kW
Mot/Eng: XU5CP
TSN: 279

PE20065 **CAT**

1704-62 9218356CAT MK 18472	1728-47 814640 MK 85737	1726-66 61592 MK 85006
		
87854 87910		82501 81324

205
XR-XT-GL-GR-GT
1.6 Autom.
07/89-97
1580 cc - 75, 89 HP - 55, 65 kW
Mot/Eng: XU51C / XU5M
Type/Typ: 20AB14-20CB14
TSN: 249, 257, 664, 667

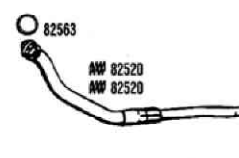
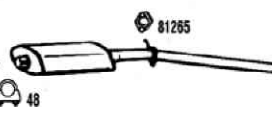
7314641 PE20616 **CAT**

1703-44 31527	1728-23 61528	1725-94 61529
		
		81324

205
GTi-CTi incl. Cabrio
1.6i
02/84-06/89
1580 cc - 104, 115 HP - 76, 85 kW
Mot/Eng: XU5J-XU5JA
ch.no. -7896592
Type/Typ: 741C66
TSN: 213, 263, 267, 473

7308584 PE20043

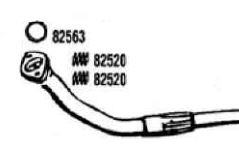
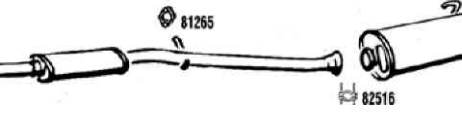
1704-95 815501	1726-69 615499 MK 85088
	
	82516 81324

205
GTi-CTi incl. Cabrio
1.6i
07/89-07/92
1580 cc - 115 HP - 83 kW
Mot/Eng: XU5JA
ch.no. 7896593-
Type/Typ: 20AB62-20CB62-20CD62-20DB62

7315502 PE20073

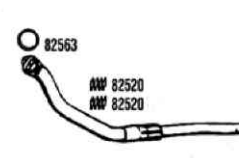
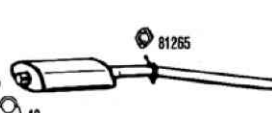
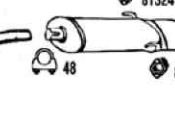
1703-44 31527	1728-23 61528	1725-94 61529
		
		81324

205
GTi-CTi incl. Cabrio
1.9i
02/84-06/89
1905 cc - 128 HP - 94 kW
Mot/Eng: XU9JA
ch.no. -7896592
Type/Typ: 20CD62
TSN: 222-255

7308584 PE20044

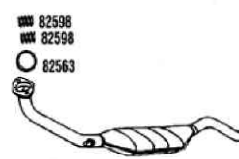
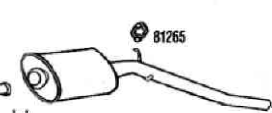
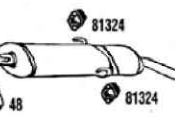
1704-62 9218356CAT MK 18472	1728-44 615642	1725-94 61529
		
87854 87910		82516 81324

205
GTi-CTi
1.9i
09/86-06/89
1905 cc - 102, 120 HP - 75, 88 kW
Mot/Eng: XU9JAZ-XU9J1
Type/Typ: 741A/C-20A/C
TSN: 254-297

7314641 PE20066 **CAT**

Los nombres y números de primer equipo se utilizan solamente como referencia

● En desarrollo

IMPORTANTE:

Al pedir sistemas de escape, rogamos completen la referencia comenzando por 'MFO.' (ejemplo: 381394 → MFO.381394)
Pour commander echappement, nous vous prions de compléter la référence en commençant par MFO..
When ordering exhaust, please complete the reference by beginning with MFO..

ESCAPE / ECHAPPEMENT / EXHAUST

Fonos

Peugeot

205
1.9 GTi
07/89-04/93
1905 cc - 102 HP - 75 kW
Mot/Eng: XU9J1
Type/Typ: 20D
TSN: 245, 268

1704-62
92**18356**CAT
MK 18472

1728-72
615278
MK 85465

1726-69
615499
MK 85088

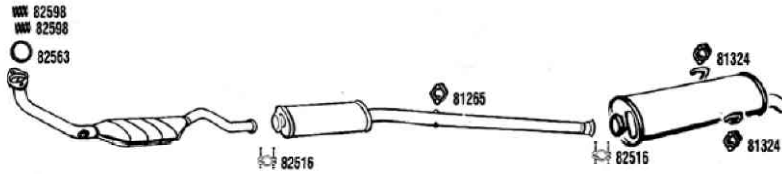

7317160

PE20619 **CAT**

A,1 87854 87910

205
GTi-CTi-Gentry incl. Cabrio
1.9i
07/89-96
1905 cc - 100, 122 HP - 74, 90 kW
Mot/Eng: XU9
Type/Typ: 20C-20D
TSN: 296

1704-62
92**18356**CAT
MK 18472

1728-72
615278
MK 85465

1726-69
615499
MK 85088

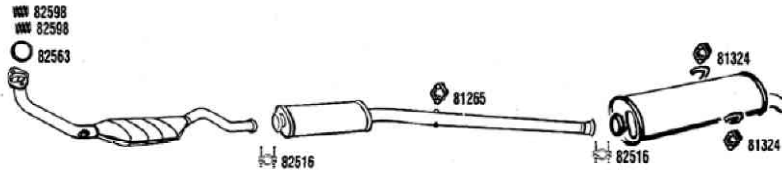

7317160

PE20095 **CAT**

A,1 87854 87910

205
1.9 GTi
07/89-07/92
1905 cc - 128 HP - 94 kW
Mot/Eng: XU9JA
ch.no. 7896593-
Type/Typ: 20CD62

1704-95
815501

1726-69
615499
MK 85088

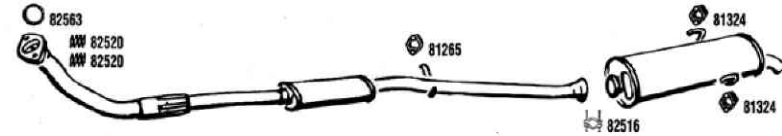

7315502

PE20072

205
GLD-GRD-SRD-XLD-XRD-XAD
1.8 Diesel
07/83-08/85
1769 cc - 60 HP - 44 kW
Mot/Eng: XUD7
ch.no. -7104860
Type/Typ: 741A90/A98/C90/C96/S90/S98
TSN: 465-483

1721 28
613509

1703-41
31523

172621
61526



7308585

PE20005

205
GLD-GRD-SRD-XLD-XRD-XAD
1.8 Diesel
09/85-12/99
1769 cc - 60 HP - 44 kW
Mot/Eng: XUD7
ch.no. 7104861-
Type/Typ: 741A90/C96/C90/C96/S90/S98
Type/Typ: 20AA9/92-20CA9/92
TSN: 248-465-483

1721 28
613509

1703-98
31538

1726-09
61539
MK 85088



7313485

PE20039

205
XAD-Multi 
1.8 Diesel
08/85-12/99
1769 cc - 60 HP - 44 kW
Mot/Eng: XUD7
ch.no. 7104861-

1721 28
613509

1703-98
31538

1726-09
61539
MK 85088



7313485

PE20512

● En desarrollo





Los nombres y números de primer equipo se utilizan solamente como referencia

IMPORTANTE:

Al pedir sistemas de escape, rogamos completen la referencia comenzando por 'MFO.' (ejemplo: 381394 → MFO.381394)
Pour commander echappement, nous vous prions de compléter la référence en commençant par MFO..
When ordering exhaust, please complete the reference by beginning with MFO..

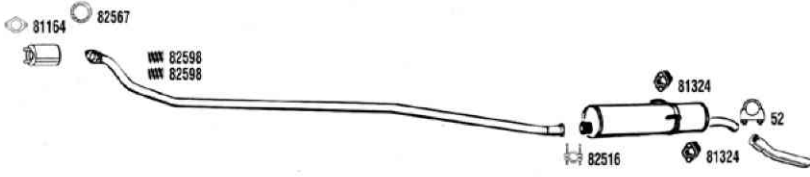
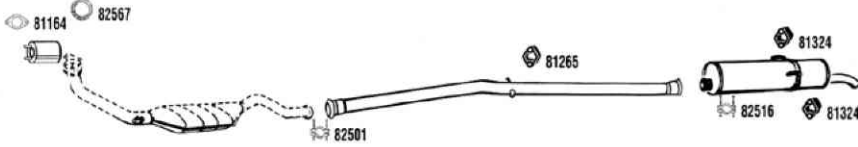
Fonos

Peugeot

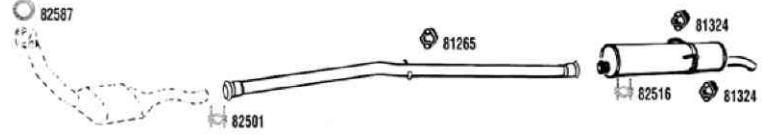
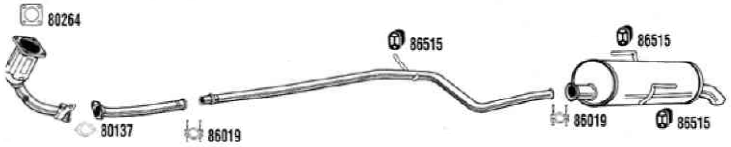
1721 28 613509	1703-98 31538	1726-09 61539 MK 85088	1765 37 6107183	205  1.8 Diesel 07/90- 1769 cc - 60 HP - 44 kW Mot/Eng: XUD7
				7313485 PE20040
1721 28 613509	1705.V7 N.D.CAT	1717-09 64 18027 MK 85737	1726-09 61539 MK 85088	205 1.8 Diesel 96-99 1769 cc - 60 HP - 44 kW Mot/Eng: XUD7
				PE20133 CAT
	1705-13 816297	1726-69 615499 MK 85088		205 DT-XTD-GTD-STDT 1.8 TD 10/89-97 1769 cc - 78 HP - 58 kW Mot/Eng: XUD7T-A8B   Type/Typ: 20AA82-20CA82
				7315496 PE20091
1721 28 613509	1703-98 31538	1726-09 61539 MK 85088		205 XL-XR-GL-GR-SR Color Line-Junior 1.9 Diesel 08/85-97 1905 cc - 65 HP - 48 kW Mot/Eng: XUD9A ch no. 7104861- TSN: 636, 637, 663, 666
				PE20041
1705-24 N.D.CAT	1717-09 64 18027 MK 85737	1726-09 61539 MK 85088		205 XLD-XRD-GLD-GRD-XSD 1.9 Diesel 10/89-97 1905 cc - 65 HP - 48 kW Mot/Eng: XUD9A Type/Typ: 20ADJ2-20CDJ2-20SDJ2 TSN: 663-666
				7318028 PE20628 CAT
1731 S4 91 20558 CAT	1705 HF 61 07162	1717J0 66 22410	1726 Y0 615882 MK 85325	206 Hatchback 1.1 i 09/98- 1124 cc - 60 HP - 44 kW Mot/Eng: HFX (TU1JP) Type/Typ: 2A/C 08D
				PEW12040 CAT

Los nombres y números de primer equipo se utilizan solamente como referencia

● En desarrollo

IMPORTANTE:

Al pedir sistemas de escape, rogamos completen la referencia comenzando por 'MFO.' (ejemplo: 381394 → MFO.381394)
 Pour commander echappement, nous vous prions de compléter la référence en commençant par MFO..
 When ordering exhaust, please complete the reference by beginning with MFO..

ESCAPE / ECHAPPEMENT / EXHAUST

Fonos

Peugeot

206
Hatchback
1.1 i
09/98-
1124 cc - 56,60 HP - 41,44 kW
Mot/Eng: HFY, HFZ (TU1JP)
Type/Typ: 2A/C
(A) repair pipe dia. 42.0mm
(B) repair pipe dia. 36.5mm

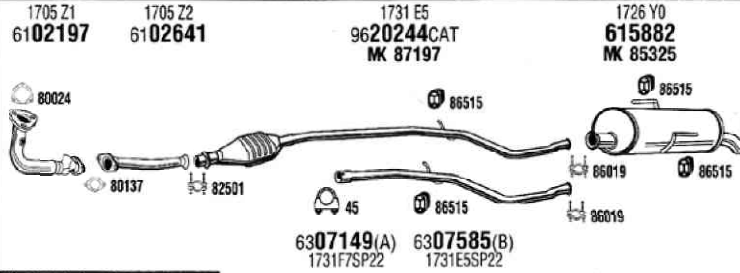

PEW12041 **CAT**

A1	87854	87919
----	-------	-------

206
Hatchback
1.4 i
09/98-
1360 cc - 75 HP - 55 kW
Mot/Eng: KFX, K6C (TU3JP) - Type/Typ: 2A/C
Transmission Type: Autom.
(A) repair pipe dia. 42.0mm
(B) repair pipe dia. 36.5mm
(C) Without chrome tailpipe
(D) With chrome tailpipe

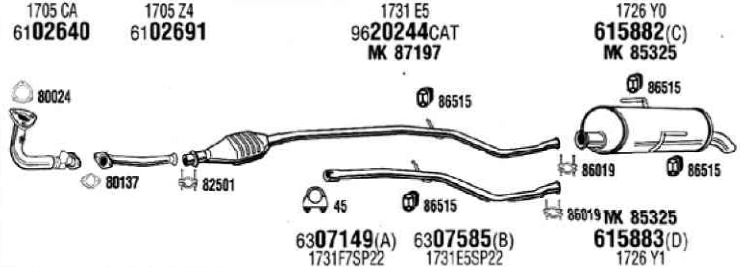

PEW12042 **CAT**

A1	87854	87919
----	-------	-------

206
Hatchback
1.4 i
09/98-
1360 cc - 75 HP - 55 kW
Mot/Eng: KFX (TU3JP) - Type/Typ: 2A/C
Transmission Type: Autom.
(A) repair pipe dia. 42.0mm
(B) repair pipe dia. 36.5mm
(C) Without chrome tailpipe
(D) With chrome tailpipe



PEW12043 **CAT**

A1	87854	87919
----	-------	-------

206
Hatchback
1.4 i
09/98-
1360 cc - 75 HP - 55 kW
Mot/Eng: KFX (TU3JP) - Type/Typ: 2A/C
Transmission Type: (A) Excl. Autom.
(B) repair pipe dia. 42.0mm
(C) repair pipe dia. 36.5mm
(D) Without chrome tailpipe
(E) With chrome tailpipe

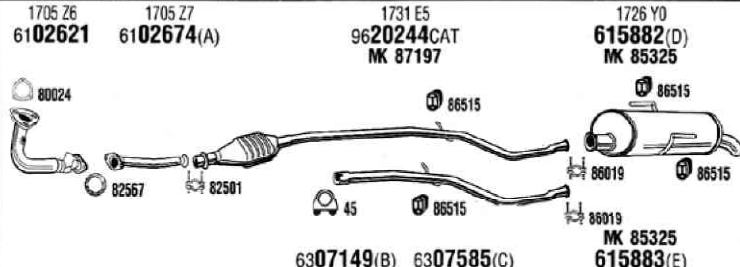

PEW12044 **CAT**

206
Hatchback
1.4 i
09/98-
1360 cc - 75 HP - 55 kW
Mot/Eng: KFW, KFX (TU3JP) - Type/Typ: 2A/C
(A) Without chrome tailpipe - 03/03
(B) Without chrome tailpipe 03/03-
(C) With chrome tailpipe
To: (D) - 11/03 - From: (E) 12/03-

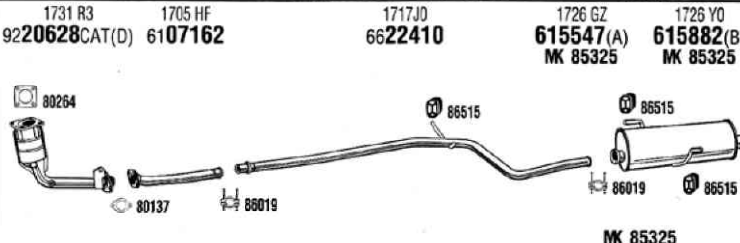

PEW12045 **CAT**

206
Hatchback
1.4 16v
10/03-
1360 cc - 88 HP - 65 kW
Mot/Eng: KFU (ET3J4)
Type/Typ: 2A/C
(A) Without chrome tailpipe
(B) With chrome tailpipe

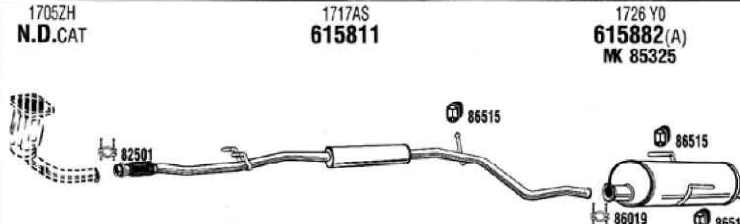

PEW12046 **CAT**

● En desarrollo

Los nombres y números de primer equipo se utilizan solamente como referencia

IMPORTANTE:

Al pedir sistemas de escape, rogamos completen la referencia comenzando por 'MFO.' (ejemplo: 381394 → MFO.381394)
Pour commander echappement, nous vous prions de compléter la référence en commençant par MFO..
When ordering exhaust, please complete the reference by beginning with MFO..

1705 CA 6102640	1705 Z4 6102691(A)	1731 E7 9120241CAT	1717 A2 615881 MK 85326	1726 Y0 615882(C) MK 85325
--------------------	-----------------------	-----------------------	-------------------------------	----------------------------------

6102716(B)
1705 CZ

615883(D)
1726 Y1

206
Hatchback
1.6 i
09/98-12/00
1587 cc - 89 HP - 65 kW
Mot/Eng: NFZ (TU5JP)
Type/Typ: 2A/C
Transmission Type:(A) Autom.
Transmission Type:(B) Autom
(C) Without chrome tailpipe
(D) With chrome tailpipe
PEW12047 **CAT**

1731 R3 9220628CAT	1705 HF 6107162	1717 H9 615894	1726 GZ 615547(A) MK 85325
-----------------------	--------------------	-------------------	----------------------------------

615503(B)
1726 GY

206
Hatchback
1.6 16v
12/00-
1587 cc - 109 HP - 80 kW
Mot/Eng: NFU (TU5JP4)
Type/Typ: 2A/C
(A) Without chrome tailpipe
(B) With chrome tailpipe
PEW12048 **CAT**

1705 HR 9220592CAT	1717 J4 615526	1726 EJ 615536(A) MK 85780
-----------------------	-------------------	----------------------------------

615529(B)
1726 CC

206
Hatchback
2.0 S16
04/99-10/00
1997 cc - 135 HP - 99 kW
Mot/Eng: RFR (DEW10J4)
Type/Typ: 2A/C
Engine Restriction:(A) GT
Engine Restriction:(B) GTI , S16
PEW12049 **CAT**

1705HHSP12 9820594CAT	1705HHSP22 615599	1726 CC 615529 MK 85780
--------------------------	----------------------	-------------------------------

N.D.CAT(A)
1705HH

206
Hatchback
2.0 S16
10/00-
1997 cc - 136 HP - 100 kW
Mot/Eng: RFN (EW10J4)
Type/Typ: 2A/C
(A) 20594+22599
PEW12050 **CAT**

1731R8 9120632CAT	6607575	1717S3SP22 6607576	1726 Y2 615884 MK 85325
----------------------	---------	-----------------------	-------------------------------

206
Hatchback
1.4 HDi
09/01-
1398 cc - 68 HP - 50 kW
Mot/Eng: 8HX (DV4TD)
Type/Typ: 2A/C
PEW12051 **CAT**

1705 Z8 9720299CAT MK 87200	1726 Y2 615884 MK 85325
-----------------------------------	-------------------------------

6407580(A)
1705Z8SP22

206
Hatchback
1.9 Diesel
09/98-11/01
1868 cc - 69 HP - 51 kW
Mot/Eng: WJY,WJZ (DW8)
Type/Typ: 2A/C
(A) repair pipe
PEW12052 **CAT**

Los nombres y números de primer equipo se utilizan solamente como referencia

● En desarrollo

IMPORTANTE:

Al pedir sistemas de escape, rogamos completen la referencia comenzando por 'MFO.' (ejemplo: 381394 → MFO.381394)
Pour commander echappement, nous vous prions de compléter la référence en commençant par MFO..
When ordering exhaust, please complete the reference by beginning with MFO..

ESCAPE / ECHAPPEMENT / EXHAUST

Fonos

Peugeot

1731R8 9120632CAT	1717S2 6808226	1726VY 615734
----------------------	-------------------	------------------

206
1.4 HDi
07/02-
1398 cc - 68 HP - 50 kW
Mot/Eng: 8HX (DV4TD)
Type/Typ: 2E/K

PEW12059 **CAT**

1705QA N.D.CAT	1717S5 6608143	1726PX 615800
-------------------	-------------------	------------------

206
2.0 HDi
07/02-
1997 cc - 90 HP - 66 kW
Mot/Eng: RHY (DW10TD)
Type/Typ: 2E/K

PEW12060 **CAT**

1731 R3 9220628CAT	1705 HF 6107162	1717 H9 615894	1726 GZ 615547(A) MK 85325
-----------------------	--------------------	-------------------	----------------------------------

206 CC
Cabrio
1.6 16v
09/00-
1587 cc - 109 HP - 80 kW
Mot/Eng: NFU (TU5JP4)
Type/Typ: 2D
(A) Without chrome tailpipe
(B) With chrome tailpipe

PEW12061 **CAT**

1705HHSP12 9820594CAT	1705HHSP22 615599	1726 CC 615529 MK 85780
--------------------------	----------------------	-------------------------------

206 CC
Cabrio
2.0 S16
09/00-
1997 cc - 136 HP - 100 kW
Mot/Eng: RFN (EW10J4)
Type/Typ: 2D
(A) 61599-615529

PEW12062 **CAT**

1720-55 N.D.	1701-81 N.D.	1724-60 6601268
-----------------	-----------------	--------------------

304
1.3
10/72-09/79
1288, 1290 cc - 65 HP - 48 kW
Mot/Eng: XL3-XL5
Type/Typ: 304M01
TSN: 369

PE30404

1720-55 N.D.	1701-77 6701256(A)	1724-54 615260
-----------------	-----------------------	-------------------

304
1.3
01/69-09/79
1288 cc - 65 HP - 48 kW
Mot/Eng: XL3
(A) - 09/72
Type/Typ: 304D01-304T01
TSN: 359

PE30413

Los nombres y números de primer equipo se utilizan solamente como referencia ● En desarrollo

IMPORTANTE:

Al pedir sistemas de escape, rogamos completen la referencia comenzando por 'MFO.' (ejemplo: 381394 → MFO.381394)
 Pour commander echappement, nous vous prions de compléter la référence en commençant par MFO..
 When ordering exhaust, please complete the reference by beginning with MFO..

MOTOR / MOTEUR / ENGINE

304
Coupé-Cabrio
 1.3
06/69-09/80
 1288 cc - 65 HP - 48 kW
 Mot/Eng: XL3-XL5
 (A) = -270 mm
 (A) = -09/72
 Type/Typ: 304C01-304B01
 TSN: 361-362

PE30419

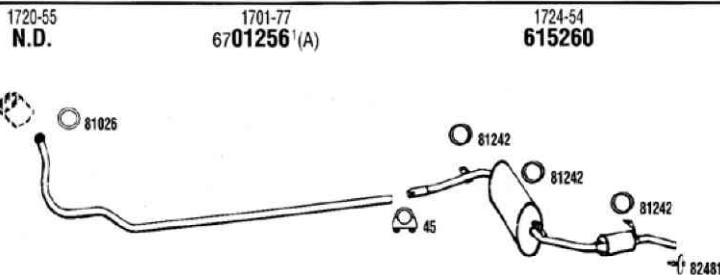

304
GLD
 1.4 Diesel
01/74-09/79
 1357 cc - 45 HP - 33 kW
 Mot/Eng: XL4D
 Type/Typ: 304M20
 TSN: 395

PE30411

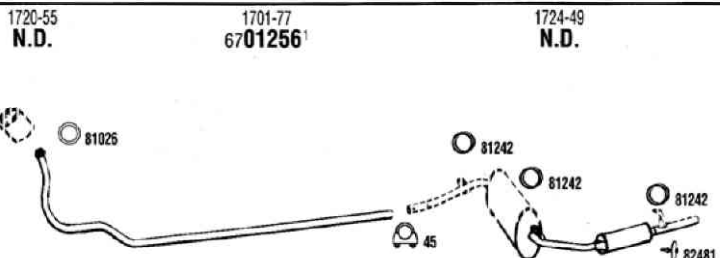

305
GL-GR-SR
 1.3
11/77-06/88
 1290 cc - 60 HP - 44 kW
 Mot/Eng: XL5
 Type/Typ: 581A01-581A11-581A21
 TSN: 288-401-402-451

PE30547

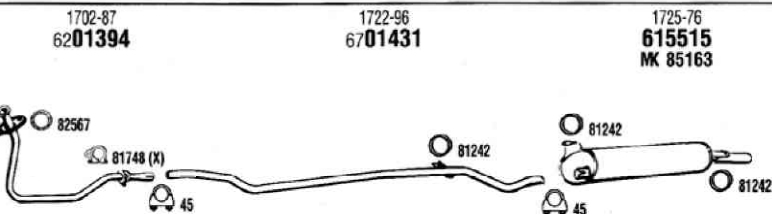

N.D.
 1720-55



7301386

305
GL-GR-Base
 1.3
03/80-06/88
 1290 cc - 60 HP - 44 kW
 Mot/Eng: XL5
 Type/Typ: 581D01/D11/E01/T01/U01/U11
 TSN: 429

PE30546

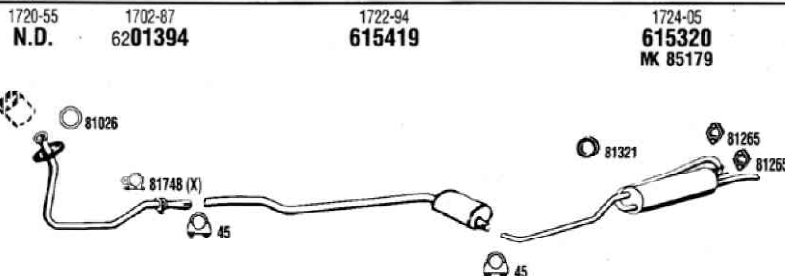

N.D.
 1720-55



7301386

305
GR-SR-GL-GLS
 1.5
11/77-07/82
 1472 cc - 74 HP - 54 kW
 Mot/Eng: XR5
 (A) = -08/79
 Type/Typ: 581M01-581M11-581A01-581A11
 TSN: 401-402-451

PE50121

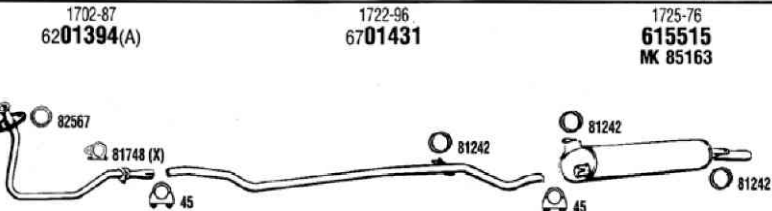

N.D.
 1720-55



7301445

305
S-SRS
 1.5
07/80-06/82
 1472 cc - 74 HP - 54 kW
 Mot/Eng: XR 5S
 ch.no. 8344701-
 Type/Typ: 581A12

PE30523

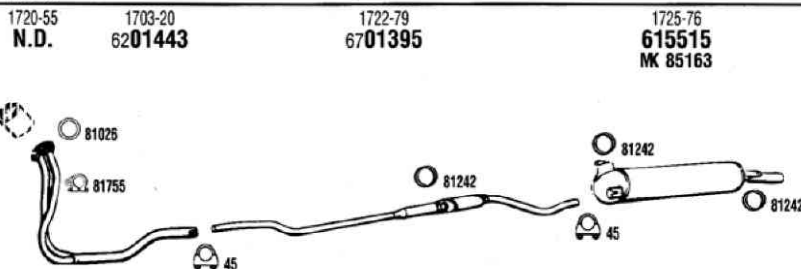

● En desarrollo

Los nombres y números de primer equipo se utilizan solamente como referencia











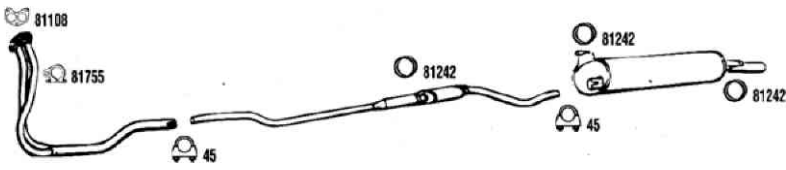

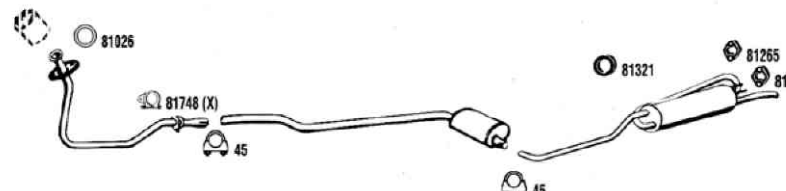
IMPORTANTE:

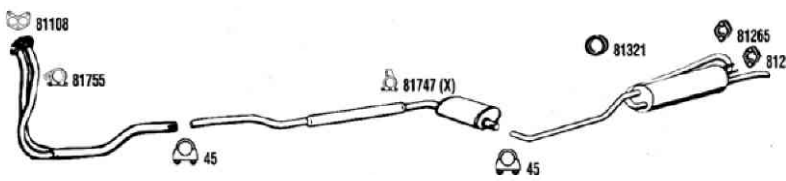
Al pedir sistemas de escape, rogamos completen la referencia comenzando por 'MFO.' (ejemplo: 381394 → MFO.381394)
 Pour commander echappement, nous vous prions de compléter la référence en commençant par MFO..
 When ordering exhaust, please complete the reference by beginning with MFO..

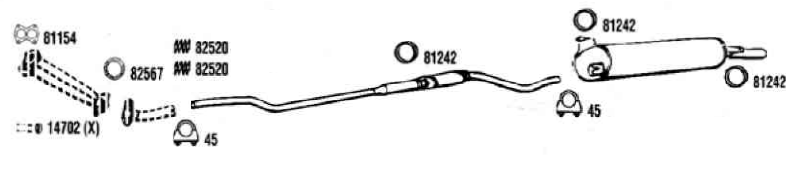
ESCAPE / ECHAPPEMENT / EXHAUST

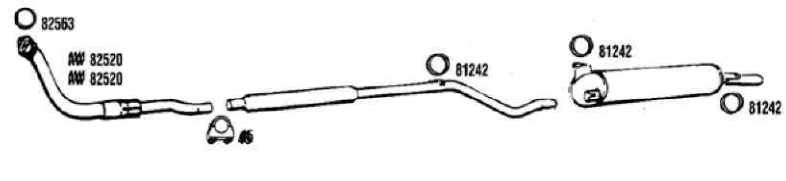
Fonos

Peugeot

1703-20 6201443	1722-79 6701395	1725-76 615515 MK 85163		305 GR-SR-GL  1.5 07/82-07/85 1472 cc - 74 HP - 54 kW Mot/Eng: XR5A Type/Typ: 581M11 TSN: 452	
7301445			PE30502		
1720-55 N.D.	1702-87 6201394	1722-94 615419	1724-05 615320 MK 85179		305 GL-GR-GLS-SR  1.5 03/80-07/82 1472 cc - 74 HP - 54 kW Mot/Eng: XR5 ch.no. -8987000 Type/Typ: 581D01/D11/E01/T01/U01/U11 TSN: 430
PE30528					
1703-20 6201443	1728-12 6601511	1724-05 615320 MK 85179		305 SR-GR  1.5 08/82-06/85 1472 cc - 74 HP - 54 kW Mot/Eng: XR5A ch.no. -8987001- Type/Typ: 581E11 TSN: 455	
PE30505					
1703-28 N.D.	1728-13 N.D.	1722-79 6701395	1725-76 615515 MK 85163		305  1.6 GT 09/82-06/85 1580 cc - 97 HP - 71 kW Mot/Eng: XU5S Type/Typ: 581M56 TSN: 460-480
7301516			PE30508		
1703-57 6308531	1728-31 6508532	1725-76 615515 MK 85163		305 GR-SR-GT  1.6 07/85-06/88 1580 cc - 75, 90, 97 HP - 55, 66, 71 kW Mot/Eng: XU51C- XU5S Type/Typ: 581M27/M54/M76/M76A/M76.1 TSN: 475-674	
7312811			PE50004		
1704-09 N.D.CAT	1728-45 N.D.	1725-76 615515 MK 85163		305 GL-GR-SR  1.6 09/86-12/87 1580 cc - 75 HP - 55 kW Mot/Eng: XU5CP TSN: 229	
PE30536			CAT		

Los nombres y números de primer equipo se utilizan solamente como referencia

● En desarrollo

IMPORTANTE:

Al pedir sistemas de escape, rogamos completen la referencia comenzando por 'MFO.' (ejemplo: 381394 → MFO.381394)

Pour commander echappement, nous vous prions de compléter la référence en commençant par MFO..

When ordering exhaust, please complete the reference by beginning with MFO..

305

1.6 GT
07/83-06/85
1580 cc - 97 HP - 71 kW
Mot/Eng: XU5S
Type/Typ: 581E56
TSN: 466

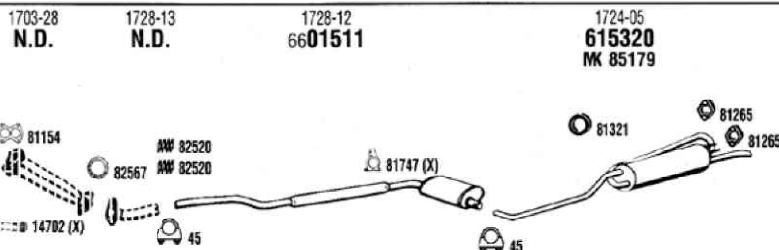

7308586

PE20006

305

GR-SR-GT
1.6
07/85-06/90
1580 cc - 90, 97 HP - 66, 71 kW
Mot/Eng: XU51C-XU5S
Type/Typ: 581E27-581E54-581E56-581U27
TSN: 477-488

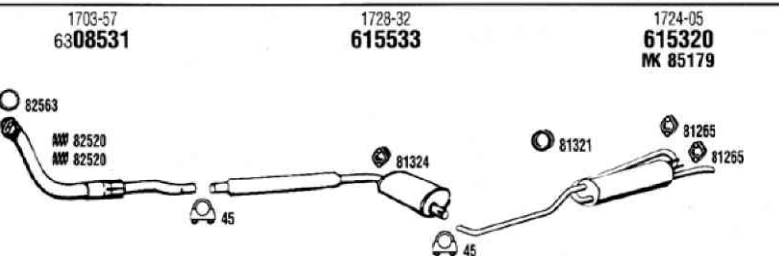

7312812

PE50005

305

GL-SR
1.6
09/86-12/88
1580 cc - 74 HP - 54 kW
Mot/Eng: XU5CP
Type/Typ: 581E54
TSN: 231

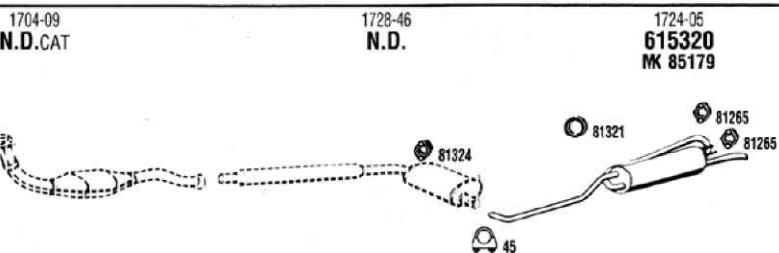

PE30538 **CAT**

305

GTX
1.9
07/84-06/88
1905 cc - 102, 105 HP - 75, 77 kW
Mot/Eng: XU9S-XU92C
Type/Typ: 581M74.1/M76/M76A/M76.1
TSN: 476

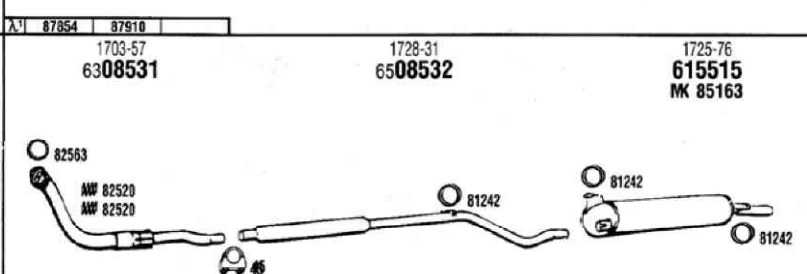

7312811

PE30542

305

SR-GTX
1.9
07/86-06/88
1905 cc - 98 HP - 72 kW
Mot/Eng: XU9J1
TSN: 230

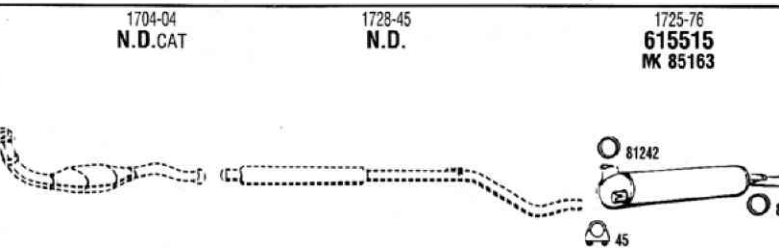

PE30537 **CAT**

305

GR-SR-GTX
1.9
07/84-06/88
1905 cc - 102, 105 HP - 75, 77 kW
Mot/Eng: XU9S-XU92C
Type/Typ: 581E56/E74/E76/E76A/E76.1
TSN: 478

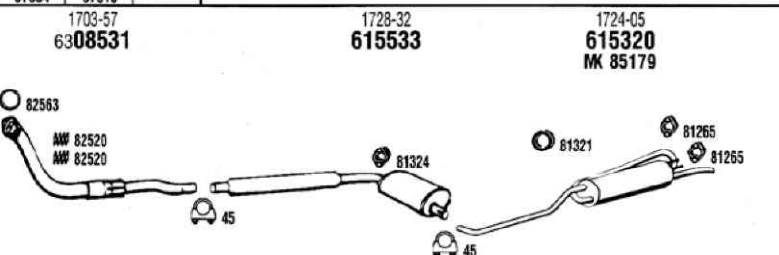

7312812

PE30530

● En desarrollo

Los nombres y números de primer equipo se utilizan solamente como referencia

IMPORTANTE:

Al pedir sistemas de escape, rogamos completen la referencia comenzando por 'MFO.' (ejemplo: 381394 → MFO.381394)
Pour commander echappement, nous vous prions de compléter la référence en commençant par MFO..
When ordering exhaust, please complete the reference by beginning with MFO..

ESCAPE / ECHAPPEMENT / EXHAUST

Fonos

Peugeot

1704-04 N.D.CAT	1728-46 N.D.	1724-05 615320 MK 85179
--------------------	-----------------	--------------------------------------

305
GTX
1.9
07/86-06/88
1905 cc - 98 HP - 72 kW
Mot/Eng: XU9J1
Type/Typ: 581E54/E74/E76/E76.1
TSN: 232

1702-87 62 01394	1722-79 67 01395	1725-76 615515 MK 85163
----------------------------	----------------------------	--------------------------------------

PE30539 **CAT**
305
GLD-GRD-SRD
1.6 Diesel
09/78-09/80
1548 cc - 47 HP - 35 kW
Mot/Eng: X1D
ch.no. -8597887
Type/Typ: 561A30
TSN: 414

1720-55 N.D.	1702-87 62 01394	1722-96 67 01431	1725-76 615515 MK 85163
-----------------	----------------------------	----------------------------	--------------------------------------

73**01386** PE30526
305
GLD-GRD-SRD
1.6 Diesel
10/80-07/82
1548 cc - 47 HP - 35 kW
Mot/Eng: X1D
ch.no. 8597888-8987000
Type/Typ: 561A30
TSN: 414

1702-87 62 01394	1722-94 615419	1724-05 615320 MK 85179
----------------------------	--------------------------	--------------------------------------

73**01386** PE30527
305
GLD-SRD-GRD
1.6 Diesel
03/80-07/82
1580 cc - 47 HP - 35 kW
Mot/Eng: X1D
ch.no. 5598888-
Type/Typ: 561D30-581T30
TSN: 431

1721 28 613509	1703-18 61 01510	1722-96 67 01431	1725-76 615515 MK 85163
--------------------------	----------------------------	----------------------------	--------------------------------------

PE30506
305
GLD-GRD-SRD
1.8 Diesel
07/84-12/88
1769 cc - 59 HP - 44 kW
Mot/Eng: XUD7
Type/Typ: 561M68

1721 28 613509	1703-18 61 01510	1722-94 615419	1724-05 615320 MK 85179
--------------------------	----------------------------	--------------------------	--------------------------------------

73**01386** PE30532
305
GLD-GRD-SRD
1.8 Diesel
07/84-12/89
1769 cc - 59 HP - 44 kW
Mot/Eng: XUD7
Type/Typ: 561E68-561U60-561U68

Los nombres y números de primer equipo se utilizan solamente como referencia ● En desarrollo

IMPORTANTE:

Al pedir sistemas de escape, rogamos completen la referencia comenzando por 'MFO.' (ejemplo: 381394 → MFO.381394)
Pour commander echappement, nous vous prions de compléter la référence en commençant par MFO..
When ordering exhaust, please complete the reference by beginning with MFO..

MOTOR / MOTEUR / ENGINE

Peugeot

Fonos

305

1.9 Diesel
07/82-12/88
1905 cc - 65 HP - 48 kW
Mot/Eng: XUD9
ch.no. 8987001-
Type/Typ: 581M40-581M45-581M48

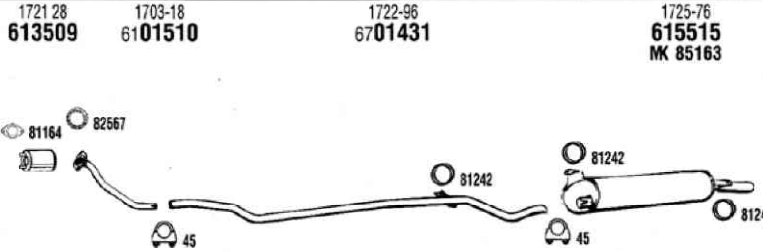

PE30509

305

GLD-GRD-SRD
1.9 Diesel
08/82-06/90
1905 cc - 65 HP - 48 kW
Mot/Eng: XUD9
ch.no. 8987001-
Type/Typ: 581E40/E45/E48/U40/U48
TSN: 456-489

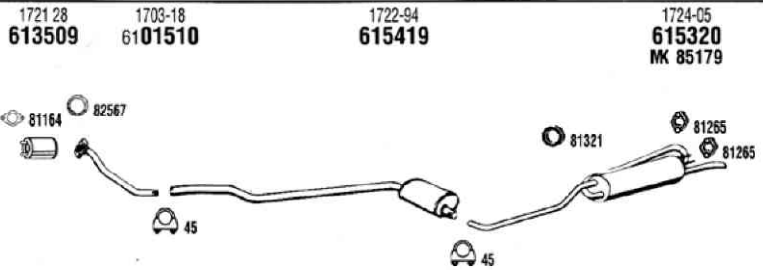

PE30507

306

XN-XR-XA Hatchback
1.1i
03/93-04/97
1124 cc - 60 HP - 44 kW
Mot/Eng: TU1M
Type/Typ: 7AHDY2-7CHDZ2-7SHDY2-7SHDZ2
Type/Typ: 7CHDY2-7CHDZ2 - TSN: 727
λ¹=01/93->02/95
λ²=03/95->04/97

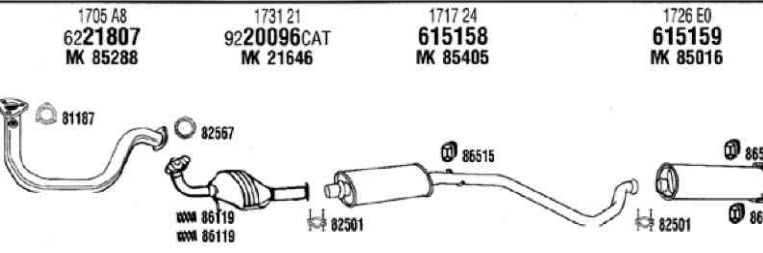

PE30613

CAT

306

XN Hatchback
1.4i
01/93-04/97
1361 cc - 75 HP - 55 kW
Mot/Eng: TU3M
Type/Typ: 7AKDX2
TSN: 719
λ¹=01/93->02/95
λ²=03/95->04/97

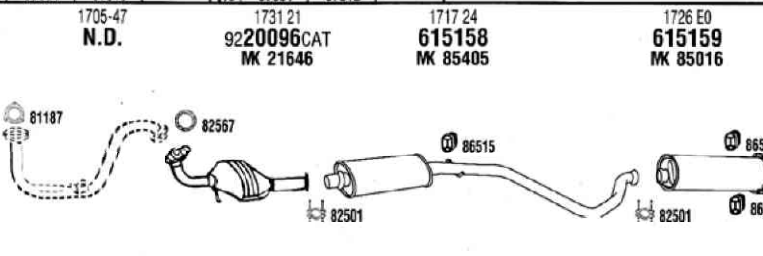

PE30602

CAT

306

XL-XN-XR-XT-XA-XRA
Hatchback
1.4i
04/94-04/97
1361 cc - 75 HP - 55 kW
Mot/Eng: TU3MC
Type/Typ: 7CKDX2-7AKDX2-7SKDX2 - TSN: 728
λ¹=04/94->02/95
λ²=03/95->04/97

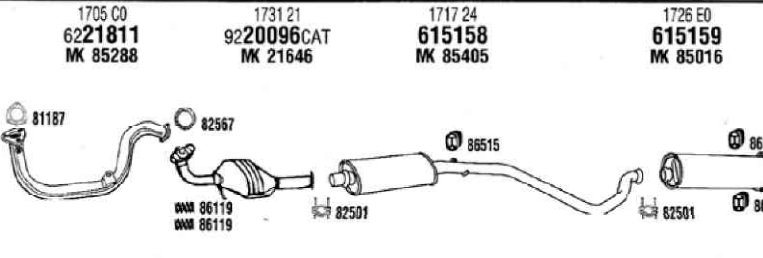

PE30615

CAT

306

Hatchback
1.4i
05/97-05/01
1360 cc - 75 HP - 55 kW
Mot/Eng: TU3JP (KFX)
(A) Depol CEE 95 & D3 - (B) Depol CEE 2000
(C) Depol CEE 95 (D) Depol D3
(E)=W0 chrome tail pipe - (F)=W chrome tail pipe
Type/Typ: 7AK*-7CK*
λ¹=Depol CEE95/EURO96
PE30648

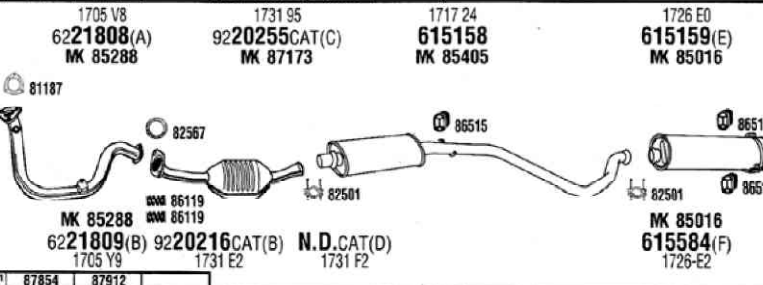

● En desarrollo

Los nombres y números de primer equipo se utilizan solamente como referencia

IMPORTANTE:

Al Al pedir sistemas de escape, rogamos completen la referencia comenzando por 'MFO.' (ejemplo: 381394 → MFO.381394)
Pour commander echappement, nous vous prions de compléter la référence en commençant par MFO..
When ordering exhaust, please complete the reference by beginning with MFO..

ESCAPE / ECHAPPEMENT / EXHAUST

Fonos

Peugeot

1705-53 N.D.CAT	1717 26 615564 MK 85464	1726 80 615177 MK 85537
--------------------	-------------------------------	-------------------------------

82563, 82516, 86515, 86513, 86515

7319566

306
S16-Le Mans Hatchback
2.0i 16v
10/93-04/97
1998 cc - 150, 152 HP - 110, 112 kW
Mot/Eng: XU10J4
Type/Typ: 7ARF2-7ARFY2-7CRF2-7CRFY2
TSN: 734-736
λ¹=10/93->02/95
λ²=03/95->04/97

PE30619 **CAT**

1705-59 N.D.CAT	1717 26 615564 MK 85464	1726 80 615177 MK 85537
--------------------	-------------------------------	-------------------------------

82563, 82516, 86515, 86513, 86515

7319566

306
XS Hatchback
2.0i
03/94-04/97
1998 cc - 121 HP - 89 kW
Mot/Eng: XU10J2
λ¹=10/93->02/95
λ²=03/95->04/97

PE30638 **CAT**

1705 52 9220296CAT MK 18473	1717 26 615564 MK 85464	1726 80 615177 MK 85537
-----------------------------------	-------------------------------	-------------------------------

86119, 86119, 82563, 82516, 86515, 86513, 86515

7319566

306
XS Hatchback
2.0i
03/94-04/97
1998 cc - 121 HP - 89 kW
Mot/Eng: XU10J2
Kat Type/Typ: CEE 95
TSN: 733
λ¹=10/93->02/95
λ²=03/95->04/97

PE30636 **CAT**

1705 52 9220296CAT MK 18473	1717 26 615564 MK 85464	1726 F6 615567(A) MK 85537
-----------------------------------	-------------------------------	----------------------------------

86119, 86119, 82563, 82516, 86515, 86513, 86515

7319072

306
Hatchback
2.0 Automm.
05/97-05/01
1998 cc - 135 HP - 99 kW
Mot/Eng: XU10J4R
(A)= without chrome finisher
(B)= with chrome finisher
Type/Typ: 7ARF*-7CRF*

PE30695 **CAT**

1705 L8 9220388CAT MK 21826	1717 26 615564 MK 85464	1726 80 615177 MK 85537
-----------------------------------	-------------------------------	-------------------------------

83181, 83181, 82563, 86119, 86119, 82501, 86515, 86513, 86515

7319072

306
Hatchback
2.0i 16v
03/96-02/02
1998 cc - 167 HP - 123 kW
Mot/Eng: XU10J4RS
Type/Typ: 7CR

PE85052 **CAT**

1721 26 613509	1705-60 615183 MK 85463	1726 E0 615159 MK 85016
-------------------	-------------------------------	-------------------------------

81164, 82567, 86515, 82501, 86515, 86515

7319072

306
XRD Hatchback
1.8 Diesel
07/93-
1769 cc - 60 HP - 44 kW
Mot/Eng: XUD7
Type/Typ: 7AA9A2-7CA9A2-7SA9A2
TSN: 746

PE30605

Los nombres y números de primer equipo se utilizan solamente como referencia ● En desarrollo

IMPORTANTE:

Al pedir sistemas de escape, rogamos completen la referencia comenzando por 'MFO.' (ejemplo: 381394 → MFO.381394)
 Pour commander echappement, nous vous prions de compléter la référence en commençant par MFO..
 When ordering exhaust, please complete the reference by beginning with MFO..

MOTOR / MOTEUR / ENGINE

Peugeot

Fonos

306
XRD-XND-XLD-XAD H'back
 1.9 Diesel
07/93-
 1905 cc - 70 HP - 51 kW
 Mot/Eng: XUD9A
 Type/Typ: 7AD9B2-7ADJY2/72-7CD9B2
 Type/Typ: 7CDJY2-7SD9B2-7SDJY2/22

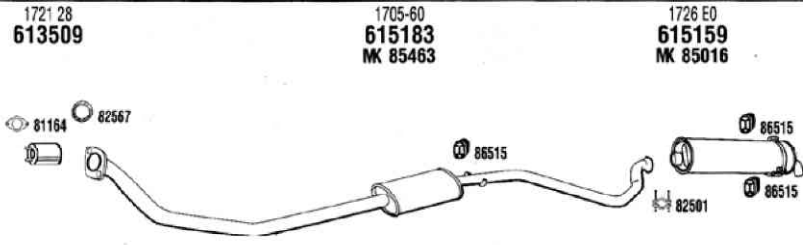

PE30620
306
XRD-XND-XAD Hatchback
 1.9 Diesel
01/94-04/97
 1905 cc - 64, 68 HP - 47, 50 kW
 Mot/Eng: XUD9
 Type/Typ: 7ADJZ2-7CDJZ2-7SDJZ2
 TSN: 732-746

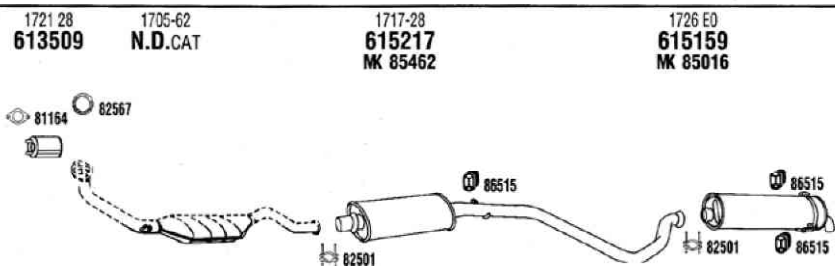

PE30621 **CAT**
306
Hatchback
 1.9 Diesel
05/97-05/98
 1905 cc - 68 HP - 50 kW
 Mot/Eng: XUD9A
 -05/98 (= 0.07848)
 (A) W/O chrome finish - (B) W/ chrome finish
 Type/Typ: 7AD9B2-7CD9B2

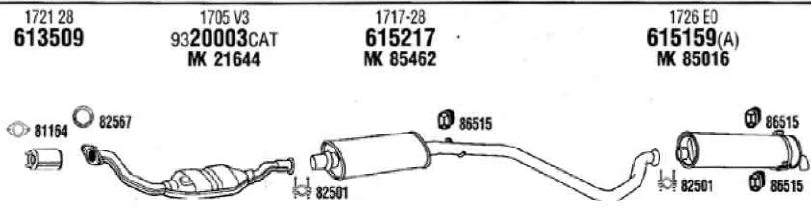

PE30672 **CAT**
306
Hatchback
 1.9 Diesel
05/98-04/99
 1905 cc - 68 HP - 50 kW
 Mot/Eng: XUD9A
 05/98- (= 0.07849)
 (A) W/O chrome finish - (B) W/ chrome finish
 (C) Repair pipe Cat
 Type/Typ: 7AD9B2-7CD9B2

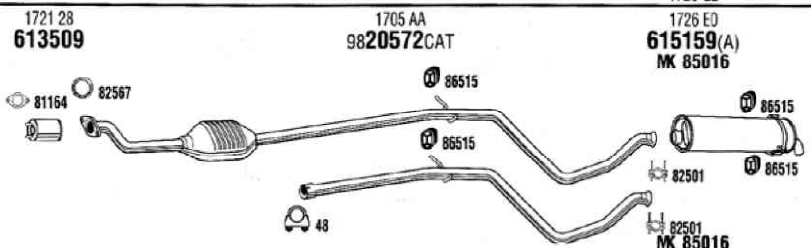

PE30697 **CAT**
306
Hatchback
 1.9 Diesel
05/97-04/99
 1868 cc - 69 HP - 51 kW
 Mot/Eng: XUD9BSD
 Type/Typ: 7AWBZ1, 7CWBZT

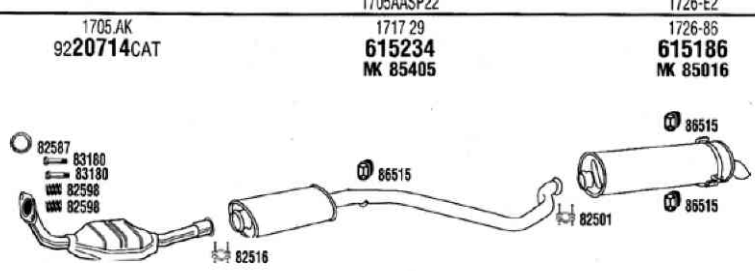

PE85022 **CAT**
306
Hatchback
 1.9 Diesel
05/99-05/01
 1868 cc - 69 HP - 51 kW
 Mot/Eng: DW8-DW8B
 (A)= without chrome (B)= with chrome
 (C)= Depol. CEE95 (D)= Depol. CEE2000
 Type/Typ: 7AWJ*-7CWJ*

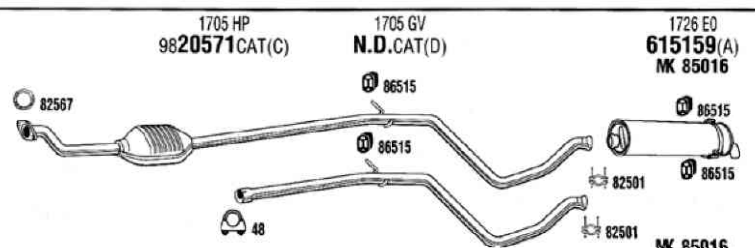

● En desarrollo

Los nombres y números de primer equipo se utilizan solamente como referencia

IMPORTANTE:

Al pedir sistemas de escape, rogamos completen la referencia comenzando por 'MFO.' (ejemplo: 381394 → MFO.381394)
 Pour commander echappement, nous vous prions de compléter la référence en commençant par MFO..
 When ordering exhaust, please complete the reference by beginning with MFO..

ESCAPE / ECHAPPEMENT / EXHAUST

Fonos

Peugeot

MOTOR / MOTEUR / ENGINE

<p>1731 L8 9220649CAT</p> <p>80264, 82567, 86515</p>	<p>1717N3 N.D.</p>	<p>1726JX N.D.</p>	<p>306 Hatchback 1.4 09/00-03/02 1360 cc - 75 HP - 55 kW Mot/Eng: TU3JP Type/Typ: 7AK.7CK</p>	
<p>PE85053 CAT</p>				
<p>1705-49 6208300</p> <p>81187, 82598, 82587, 82501, 86515</p>	<p>1731-50 9220091CAT MK 21644</p>	<p>1717 24 615158 MK 85405</p>		<p>1726 E0 615159 MK 85016</p>
<p>7319069</p>			<p>PE30603 CAT</p>	
<p>1705-C1 N.D.</p> <p>81187, 82598, 82587, 82501, 86515</p>	<p>1731-50 9220091CAT MK 21644</p>	<p>1717 24 615158 MK 85405</p>	<p>1726 E0 615159 MK 85016</p>	
<p>7319069</p>			<p>PE30616 CAT</p>	
<p>1705-49 6208300</p> <p>81187, 82598, 82587, 82501, 86515</p>	<p>1731-50 9220091CAT MK 21644</p>	<p>1717 24 615158 MK 85405</p>	<p>1726 E2 615584 MK 85016</p>	
<p>7319069</p>			<p>PE30633 CAT</p>	
<p>1705 W0 6221810(A) MK 85288</p> <p>81187, 82587, 85119, 86515, 82501</p>	<p>1731 96 9220245CAT(A) MK 21644</p>	<p>1717 24 615158 MK 85405</p>	<p>1726 E0 615159(C) MK 85016</p>	
<p>7319069</p>			<p>PE30651 CAT</p>	
<p>1705 W0 6221810(A) MK 85288</p> <p>81187, 82587, 85119, 86515, 82501</p>	<p>1731 96 9220245CAT MK 21644</p>	<p>1717 24 615158 MK 85405</p>	<p>1726 E0 615159(C) MK 85016</p>	
<p>7319069</p>			<p>PE30687 CAT</p>	

Los nombres y números de primer equipo se utilizan solamente como referencia

● En desarrollo

IMPORTANTE:

Al pedir sistemas de escape, rogamos completen la referencia comenzando por 'MFO.' (ejemplo: 381394 → MFO.381394)

Pour commander echappement, nous vous prions de compléter la référence en commençant par MFO..

When ordering exhaust, please complete the reference by beginning with MFO..

306
XT-XR-XS Hatchback-Cabrio
 1.8i incl. Autom.
01/93-04/94
 1761 cc - 101 HP - 74 kW
 Mot/Eng: XU7JP
 Type/Typ: 7ALFZ2/24/Z8-7AD/CD9982-7AA9A2
 TSN: 720-729

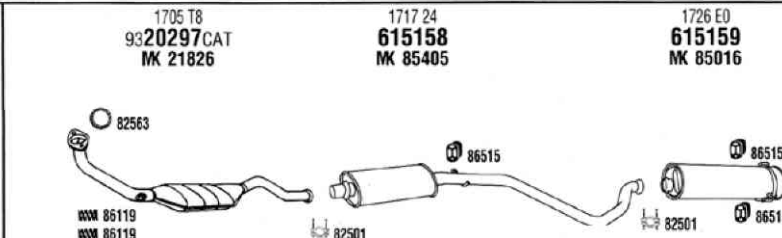

PE30604 **CAT**

87854 87910 87999x2 7319069

306
XR-XS-XT Hatchback
 1.8i
06/94-04/97
 1762 cc - 101 HP - 74 kW
 Mot/Eng: XU7JP
 Type/Typ: 7ALFZ2/24/Z8-7AD/CD9982-7AA9A2
 TSN: 729
 λ¹: 06/94-02/95
 λ²: 03/95-04/97

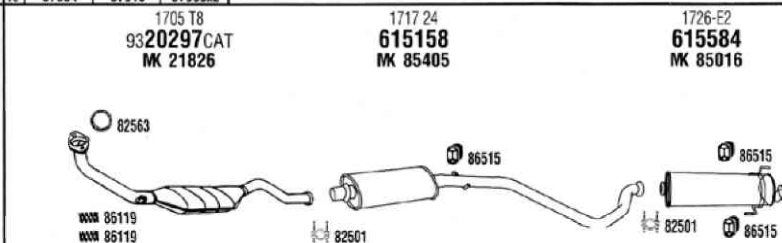

PE30634 **CAT**

87854 87910 87999x2 87854 87912 7319069

306
Hatchback
 1.8i 8v
05/97-04/99
 1761 cc - 101 HP - 74 kW
 Mot/Eng: XU7JP
 (A) W/O chrome tail pipe
 (B) W/ chrome tail pipe
 Type/Typ: 7ALFZ4
 TSN: 720-729-833

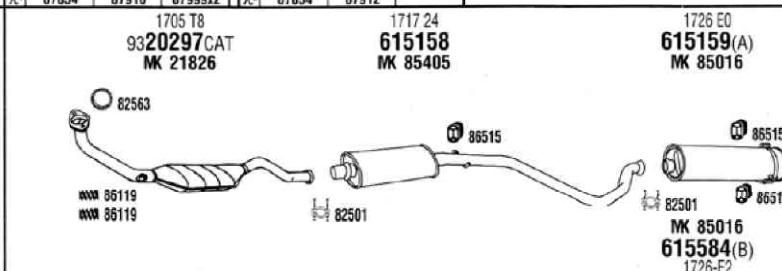

PE30656 **CAT**

87854 87912 7319069

306
Hatchback
 1.8i 16v
04/97-02/02
 1761 cc - 110 HP - 81 kW
 Mot/Eng: XU7JP4
 (A)= Depol. L3 & Depol. D3 (B)= Depol. L4
 (C)= W/O Chrome - (D) = W/ Chrome
 Type/Typ: 7ALF*-7CLF*

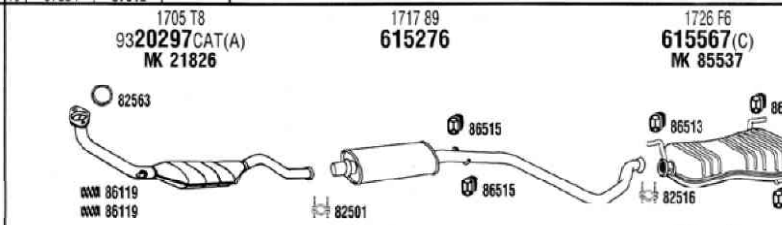

PE30659 **CAT**

N.D.CAT(B) 1705 KW MK 85537 615177(D) 1726 80

306
XSi Hatchback
 2.0i DOHC
10/93-04/97
 1998 cc - 121 HP - 89 kW
 Mot/Eng: XU10J2
 Type/Typ: 7AR6D2-7ARFX2/4-7CRFX2/FX4/6D2
 TSN: 733
 λ¹: 10/93-02/95
 λ²: 03/95-04/97

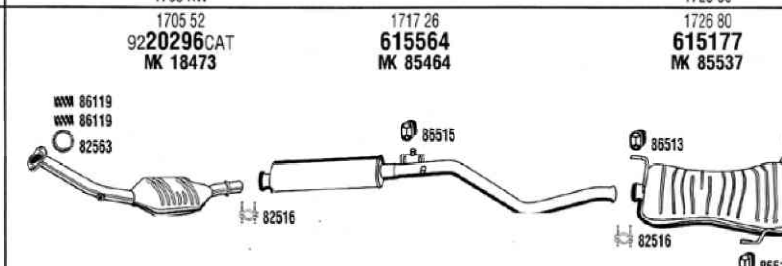

PE30617 **CAT**

87854 87910 87999x2 87854 87912 7319566

306
Gentry-Griffe Hatchback
 2.0i DOHC
10/93-04/97
 1998 cc - 121 HP - 89 kW
 Mot/Eng: XU10J2
 Type/Typ: 7ARFX2/X24-7ARFX2-7CRFX4
 TSN: 733
 λ¹: 10/93-02/95
 λ²: 03/95-04/97

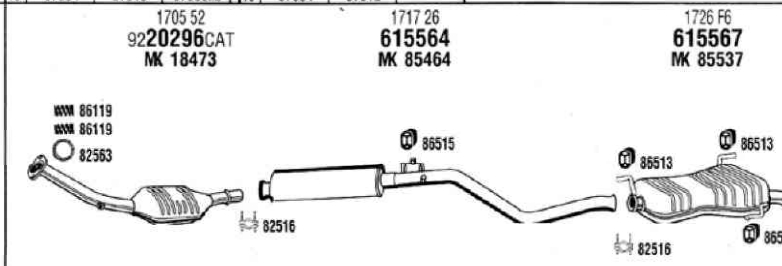

PE30618 **CAT**

87854 87910 87999x2 87854 87912 7319566

● En desarrollo

Los nombres y números de primer equipo se utilizan solamente como referencia

IMPORTANTE:

Al pedir sistemas de escape, rogamos completen la referencia comenzando por 'MFO.' (ejemplo: 381394 → MFO.381394)
 Pour commander echappement, nous vous prions de compléter la référence en commençant par MFO..
 When ordering exhaust, please complete the reference by beginning with MFO..

ESCAPE / ECHAPPEMENT / EXHAUST

Fonos

Peugeot

1705-61 615185 MK 85463	1726-86 615186 MK 85016
--------------------------------------	--------------------------------------

7319072

306
XNDT-XRDT-XTDT Hatchback
1.9 TD
07/93-
1905 cc - 92 HP - 68 kW
Mot/Eng: XUD9TE-XUD9TC
Type/Typ: 7AD8A2, 7ADHY2, 7CD8A2
TSN: 731

PE30607

1705-61 615185 MK 85463	1726 E3 615187 MK 85016
--------------------------------------	--------------------------------------

7319072

306
Hatchback
1.9 TD
07/94-
1905 cc - 92 HP - 68 kW
Mot/Eng: XUD9TE
Type/Typ: 7AD8A2-7CD8A2

PE30643

1705 V4 9320318CAT MK 21644	1717 29 615234 MK 85405	1726-86 615186(A) MK 85016
--	--------------------------------------	---

7319069

306
Hatchback
1.9 DT TD
07/93-07/98
1905 cc - 90 HP - 66 kW
Mot/Eng: XUD9TE
(A) W/O chrome finish
(B) W/ chrome finish
Type/Typ: 7AD8A2-7CD8A2-7ADHY2-7CDHY2
TSN: 731

PE30606 **CAT**

1705 EZ 9220589CAT(A)	1717 29 615234 MK 85405	1726-86 615186(B) MK 85016
---------------------------------	--------------------------------------	---

7319069

306
Hatchback
2.0 HDi
08/98-05/01
1997 cc - 90 HP - 66 kW
Mot/Eng: DW10TD
(A)= Depol CEE95
(B)= W/O Chrome finisher - (C) Chrome finisher
Type/Typ: 7ARH*-7CRH

PE85023 **CAT**

1705 V8 6221808(A) MK 85288	1731 95 9220255CAT(C) MK 87173	1717-37 615180 MK 85462	1726-C0 615181 MK 85016
--	---	--------------------------------------	--------------------------------------

7319069

306
1.4i
05/97-05/01
1360 cc - 75 HP - 55 kW
Mot/Eng: TU3JP (KFX)
(A) Depol CEE 95 & D3 (B) Depol CEE 2000
(C) Depol CEE 95 (D) Depol D3
Type/Typ: 7BK*
λ¹=Depol CEE95/EUR96

PE30649 **CAT**

1705-47 N.D.	1731 21 9220096CAT MK 21646	1717-37 615180 MK 85462	1726-C0 615181 MK 85016
------------------------	--	--------------------------------------	--------------------------------------

7319069

306
1.4i
06/94-04/97
1361 cc - 75 HP - 55 kW
Mot/Eng: TU3MC
Type/Typ: 7BKDX2
TSN: 748
λ¹=04/94-02/96
λ²=03/95-04/97

PE30630 **CAT**

Los nombres y números de primer equipo se utilizan solamente como referencia

● En desarrollo

IMPORTANTE:

Al pedir sistemas de escape, rogamos completen la referencia comenzando por 'MFO.' (ejemplo: 381394 → MFO.381394)
 Pour commander echappement, nous vous prions de compléter la référence en commençant par MFO..
 When ordering exhaust, please complete the reference by beginning with MFO..

MOTOR / MOTEUR / ENGINE

Peugeot

Fonos

306

 1.4i
06/94-04/97
 1361 cc - 75 HP - 55 kW
 Mot/Eng: TU3MC
 Type/Typ: 7BKDX2
 TSN: 748
 λ¹-04/94->02/95
 λ²-03/95->04/97

1705 C0 62**21811** MK 85288
 1731 21 92**20096**CAT MK 21646
 1717-37 **615180** MK 85462
 1726-C0 **615181** MK 85016

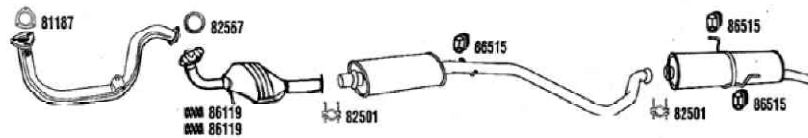

PE30629 **CAT**

λ¹ 87854 87910 λ² 87854 87912

7319069

306

 1.4
09/00-03/02
 1360 cc - 75 HP - 55 kW
 Mot/Eng: TU3JP
 Type/Typ: 7BK,7BN

1731 L8 92**20649**CAT
 1717N5 **N.D.**
 1726JZ **N.D.**



PE85050 **CAT**



306

 1.6i
06/94-04/97
 1587 cc - 89 HP - 65 kW
 Mot/Eng: TU5JP
 Kat Type/Typ: CEE 195
 Type/Typ: 7BNF22
 TSN: 750, 838
 λ¹-06/94->02/95
 λ²-03/95->04/97

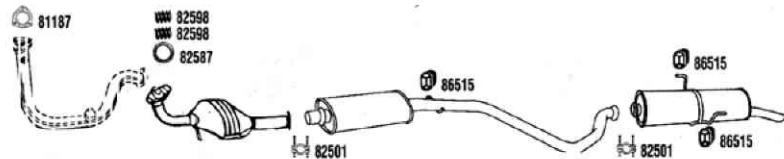
1705-C1 **N.D.**
 1731-50 92**20091**CAT MK 21644
 1717-37 **615180** MK 85462
 1726-C0 **615181** MK 85016



PE30631 **CAT**

λ¹ 87854 87910 λ² 87854 87912

7319069

306

 1.6i
06/94-04/97
 1587 cc - 89 HP - 65 kW
 Mot/Eng: TU5JP
 Kat Type/Typ: CEE 95-L3
 λ¹-06/94->02/95
 λ²-03/95->04/97

1705-C1 **N.D.**
 1731-50 92**20091**CAT MK 21644
 1717-37 **615180** MK 85462
 1726-C0 **615181** MK 85016

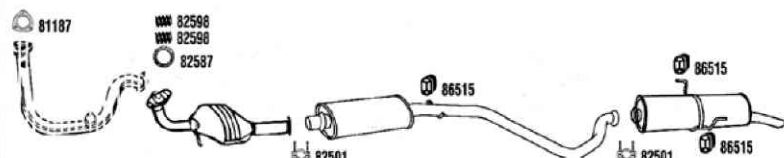

PE30632 **CAT**

λ¹ 87854 87910 λ² 87854 87912

7319069

306

 1.6i
05/97-06/00
 1587 cc - 90 HP - 66 kW
 Mot/Eng: TU5JP
 (A)= Autom. (B)= Autom.
 (C)= Depol. CEE95 Autom. (D)= Depol. CEE95 Autom.
 (E)= Depol. D3 - Type/Typ: 7BN* - TSN: 750-838
 λ¹-05/97->06/98 exc. Depol. EURO2000
 λ²-07/98->00/01 exc. Depol. EURO2000

1705 W0 62**21810**(A) MK 85288
 1731 96 92**20245**CAT(C)(E) MK 21644
 1731 H7 92**20336**CAT(D)
 1717-37 **615180** MK 85462
 1726-C0 **615181** MK 85016

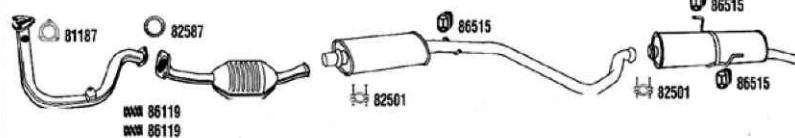

N.D.CAT(B)
 1705 FF

PE30652 **CAT**

λ¹ 87854 87912 λ² 87854 87919

306
XR-XS-XT 
 1.8i
06/94-04/97
 1762 cc - 101 HP - 74 kW
 Mot/Eng: XU7JP
 Type/Typ: 7BLFZ2-7BLFZ4
 TSN: 749
 λ¹-06/94->02/95
 λ²-03/95->04/97

1705 T8 93**20297**CAT MK 21826
 1717-37 **615180** MK 85462
 1726-C0 **615181** MK 85016

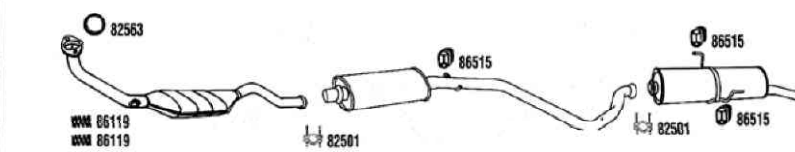

PE30635 **CAT**

λ¹ 87854 87910 87999x2

7319069

● En desarrollo

Los nombres y números de primer equipo se utilizan solamente como referencia

IMPORTANTE:

Al pedir sistemas de escape, rogamos completen la referencia comenzando por 'MFO.' (ejemplo: 381394 → MFO.381394)
 Pour commander echappement, nous vous prions de compléter la référence en commençant par MFO..
 When ordering exhaust, please complete the reference by beginning with MFO..

ESCAPE / ECHAPPEMENT / EXHAUST

Fonos 2007

Peugeot

1705 T8 9320297CAT MK 21826	1717-37 615180 MK 85462	1726-C0 615181 MK 85016
-----------------------------------	-------------------------------	-------------------------------

82563
86119
82501
86515
86513

87854 87912

306
1.8i
05/97-04/99
1761 cc - 101 HP - 74 kW
Mot/Eng: XU7JP
Type/Typ: 7BLFZ4
TSN: 749-830-834

PE30657 **CAT**

1705 T8 9320297CAT(A) MK 21826	1717 89 615276	1726 T1 615227 MK 85537
--------------------------------------	-------------------	-------------------------------

82563
86119
82501
86515
86513
82516
86513

N.D.CAT(B)
1705 KW

87854 87912

306
1.8i 16v
04/97-02/02
1761 cc - 110 HP - 81 kW
Mot/Eng: XU7JP4
(A)= Depol. L3 & Depol. D3 (B)= Depol. L4
Type/Typ: 7BLF*-7ELF*

PE30686 **CAT**

1705-59 N.D.CAT	1717 26 615564 MK 85464	1726 T1 615227 MK 85537
--------------------	-------------------------------	-------------------------------

82563
86119
82516
86515
86513
86515

87854 87910 87999x2 87854 87912

306
XS 2.0i
10/94-04/97
1998 cc - 121 HP - 89 kW
Mot/Eng: XU10J2
TSN: 753
λ¹=10/93->02/95
λ²=03/95->04/97

7319566 PE30639 **CAT**

1705 52 9220296CAT MK 18473	1717 26 615564 MK 85464	1726 T1 615227 MK 85537
-----------------------------------	-------------------------------	-------------------------------

86119
82563
82516
86515
86513
86513

87854 87910 87999x2 87854 87912

306
XS 2.0i
06/94-04/97
1998 cc - 121 HP - 89 kW
Mot/Eng: XU10J2
λ¹=10/93->02/95
λ²=03/95->04/97

7319566 PE30637 **CAT**

1705 52 9220296CAT(A) MK 18473	1717 26 615564 MK 85464	1726 T1 615227 MK 85537
--------------------------------------	-------------------------------	-------------------------------

86119
82563
82516
86515
86513
86515

87854 87912

306
2.0i 16v Autom.
05/97-06/00
1998 cc - 135 HP - 99 kW
Mot/Eng: XU10J4R
(A)= Depol. CEE95
Type/Typ: 7BRF*
λ¹=Eng.XU10J4R Type "RFV"

7319566 PE30642 **CAT**

1705 82 615190	1726-C3 615228 MK 85931
-------------------	-------------------------------

82587
82516
86515
86515

87854 87912

306
STDT - SRDT 1.9 TD
06/94-04/97
1905 cc - 92 HP - 68 kW
Mot/Eng: XUD9TE
Type/Typ: 7BD8A2

7319069 PE30645

Los nombres y números de primer equipo se utilizan solamente como referencia

● En desarrollo

IMPORTANTE:

Al pedir sistemas de escape, rogamos completen la referencia comenzando por 'MFO.' (ejemplo: 381394 → MFO.381394)
 Pour commander echappement, nous vous prions de compléter la référence en commençant par MFO..
 When ordering exhaust, please complete the reference by beginning with MFO..

306



1.9 DT TD

06/94-07/98

1905 cc - 90 HP - 66 kW

Mot/Eng: XUD9TE

Type/Typ: 7BD9A2/7BDHY2/7BDHYE

1705 V4
9320318CAT
NK 21644

1717-49
615225
MK 85464

1726-C3
615228
MK 85931

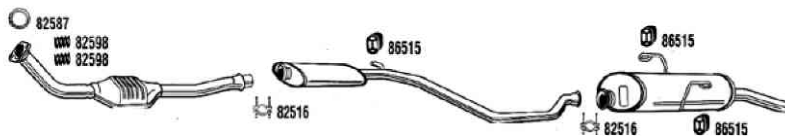

7319069

PE30646 CAT

306



1.9 Diesel

05/97-04/99

1868 cc - 69 HP - 51 kW

Mot/Eng: XUD9BSD

Type/Typ: 7BWBT

1705 AK
9220714CAT

1717-49
615225
MK 85464

1726-C3
615228
MK 85931

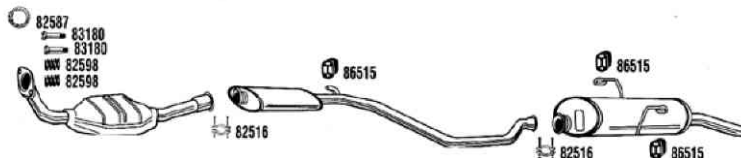

PE85041 CAT

306



1.9 Diesel

05/97-04/99

1905 cc - 68 HP - 50 kW

Mot/Eng: XUD9A

Type/Typ: 7BD9B2

1721 28
613509

1705 V3
9320003CAT
MK 21644

1717-37
615180
MK 85462

1726-C0
615181
MK 85016

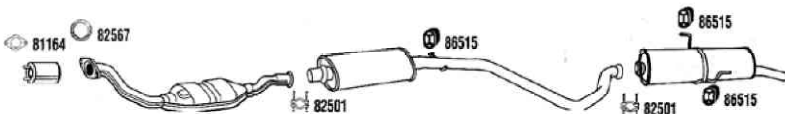

PE30675 CAT

306



1.9 Diesel

05/99-02

1868 cc - 69 HP - 51 kW

Mot/Eng: DW8-DW8B

(A) Repair pipe Cat

Type/Typ: 7BWJ*

Emission: Euro II

1705 HQ
9820587CAT

1726-C0
615181
MK 85016

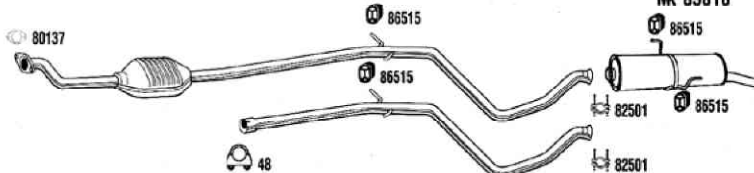

7319072

PE30693 CAT

306



1.9 Diesel

05/99-02

1868 cc - 69 HP - 51 kW

Mot/Eng: DW8-DW8B

(A) Repair pipe Cat

Type/Typ: 7BWJ*

Emission: Euro III

6807768(A)
1705HQSP22

1726-C0
615181
MK 85016

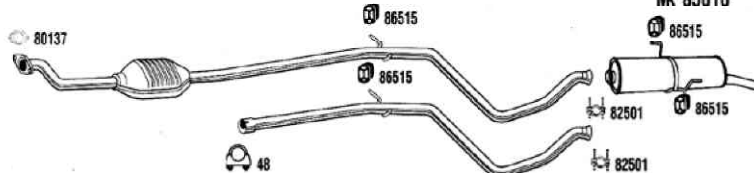

7319072

PE30698 CAT

306



2.0 HDi

08/98-05/01

1997 cc - 90 HP - 66 kW

Mot/Eng: DW10TD

(A)=Depol CEE95

Type/Typ: 7BRH*

1705 EZ
9220589CAT(A)

1717-49
615225
MK 85464

1726-C3
615228
MK 85931



PE85043 CAT

● En desarrollo

Los nombres y números de primer equipo se utilizan solamente como referencia

IMPORTANTE:

Al pedir sistemas de escape, rogamos completen la referencia comenzando por 'MFO.' (ejemplo: 381394 → MFO.381394)

Pour commander echappement, nous vous prions de compléter la référence en commençant par MFO..

When ordering exhaust, please complete the reference by beginning with MFO..

ESCAPE / ECHAPPEMENT / EXHAUST

Fonos

Peugeot

1705 V8 62 21808 (A) MK 85288	1731 95 92 20255 CAT(C) MK 87173	1717-37 61 5180 MK 85462	1726-C0 61 5181 MK 85016
--	---	---------------------------------------	---------------------------------------

81187 82567 82501 86515 86515

MK 85288 86119 86119

62**21809**(B) 92**20216**CAT(B) N.D.CAT(D)
1705 Y9 1731 E2 1731 F2

λ1 87854 87912

306
1.4i
05/97-05/01
1360 cc - 75 HP - 55 kW
Mot/Eng: TU3JP (KFX)
(A) Depol CEE 95 & D3 (B) Depol CEE 2000
(C) Depol CEE 95 (D) Depol D3
Type/Typ: 7EK* = - Type/Typ: 7SK* =
λ1=Depol CEE95/EUR095

PE30650 **CAT**

1731 L8 92 20649 CAT	1717N5 N.D.	1726KA N.D.
--------------------------------	----------------	----------------

80264 82567 86515 86515

306
1.4
09/00-03/02
1360 cc - 75 HP - 55 kW
Mot/Eng: TU3JP
Type/Typ: 7EK

PE85048 **CAT**

1705 W0 62 21810 (A) MK 85288	1731 96 92 20245 CAT(C)(E) MK 21644	1731 H7 92 20336 CAT(D) MK 85462	1717-37 61 5180 MK 85462	1726-C0 61 5181 MK 85016
--	--	---	---------------------------------------	---------------------------------------

81187 82587 82501 86515 82501 86515

86119 86119

N.D.CAT(B)
1705 FF

λ1 87854 87912 λ2 87854 87919

306
1.6i
05/97-06/00
1587 cc - 90 HP - 66 kW
Mot/Eng: TU5JP
(A)= Autom. (B)= Autom.
(C) = Depol. CEE95 Autom. (D)= Depol. CEE95 Autom.
(E)= Depol. D3 - Type/Typ: 7EN* - TSN: 839
λ1=05/97-06/98 exc. Depol. EURO2000
λ2=07/98-09/01 exc. Depol. EURO2000

PE30653 **CAT**

1705 T8 93 20297 CAT MK 21826	1717-37 61 5180 MK 85462	1726-C0 61 5181 MK 85016
--	---------------------------------------	---------------------------------------

82563 82501 86515 82501 86515

86119 86119

λ1 87854 87912

306
1.8i
05/97-04/99
1761 cc - 101 HP - 74 kW
Mot/Eng: XU7JP
Type/Typ: 7ELFZ4
TSN: 831-835

PE30658 **CAT**

1705 52 92 20296 CAT(A) MK 18473	1717-26 61 5564 MK 85464	1726 T1 61 5227 MK 85537
---	---------------------------------------	---------------------------------------

86119 86119 82563 82516 86515 86513 86515

λ1 87854 87912

306
2.0 16v
05/97-
1998 cc - 135 HP - 99 kW
Mot/Eng: XU10JAR
(A) Depol. CEE 95
Type/Typ: 7ERFX2-7ERFVE
λ1=Eng. XU10JAR Type "RFV"

PE30673 **CAT**

1721 28 61 3509	1705 V3 93 20003 CAT MK 21644	1717-28 61 5217 MK 85462	1726 E0 61 5159 MK 85016
---------------------------	--	---------------------------------------	---------------------------------------

81164 82567 82501 86515 82501 86515

306
1.8 Diesel
05/97-05/98
1769 cc - 60 HP - 44 kW
Mot/Eng: XUD7
-05/98 (= 0.07848)
Type/Typ: 7TA9AT

PE30674 **CAT**

Los nombres y números de primer equipo se utilizan solamente como referencia

● En desarrollo

IMPORTANTE:

Al pedir sistemas de escape, rogamos completen la referencia comenzando por 'MFO.' (ejemplo: 381394 → MFO.381394)
 Pour commander echappement, nous vous prions de compléter la référence en commençant par MFO..
 When ordering exhaust, please complete the reference by beginning with MFO..

Peugeot

Fonos

306

1.8 Diesel
05/98-06/00
1769 cc - 60 HP - 44 kW
Mot/Eng: XUD7
05/98- (= 0.07849)
(A) Repair pipe Cat
Type/Typ: 7TA9AT

PE30696 CAT

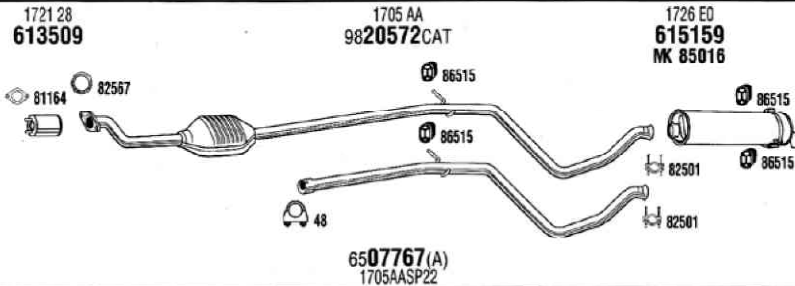

306

1.9 DT TD
05/97-07/98
1905 cc - 90 HP - 66 kW
Mot/Eng: XUD9TE
Type/Typ: 7ED8A2
TSN: 825-860

PE30655 CAT

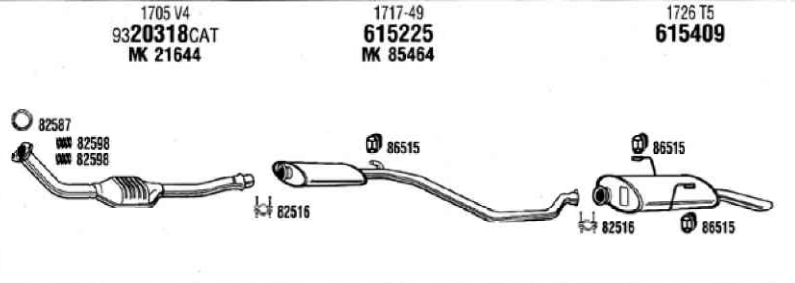

306

1.9 Diesel
05/97-04/99
1905 cc - 69 HP - 51 kW
Mot/Eng: XUD9
Type/Typ: 7TDJYE

PE30691

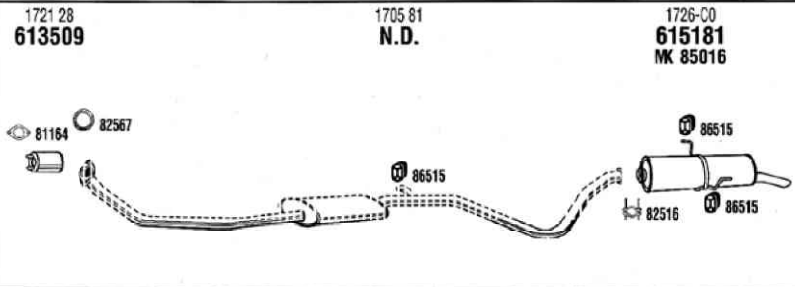

306

1.9 Diesel
05/97-04/99
1905 cc - 68 HP - 50 kW
Mot/Eng: XUD9A
Type/Typ: 7ED9B2-7TD9B2

PE30676 CAT

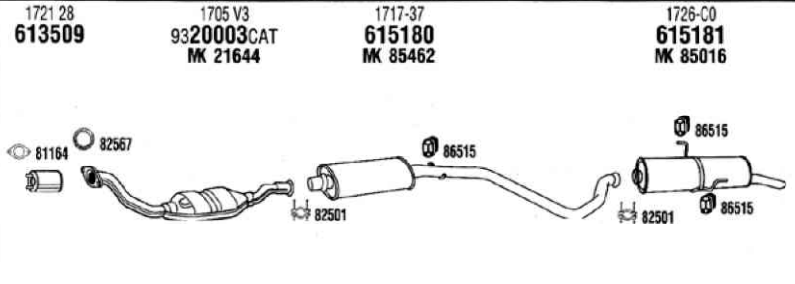

306

1.9 Diesel
05/97-04/99
1868 cc - 69 HP - 51 kW
Mot/Eng: XUD9BSD
Type/Typ: 7BWBZT

PE85042 CAT

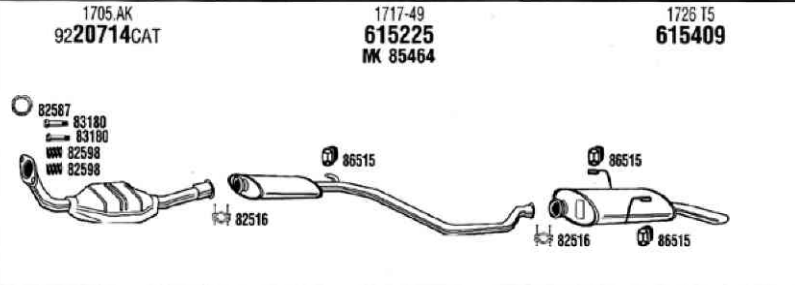

306

1.9 Diesel
05/99-02
1868 cc - 69 HP - 51 kW
Mot/Eng: DW8-DW8B
(A) Repair pipe Cat
Type/Typ: 7EWJ*-7TWJ*
Emission: Euro II

PE30694 CAT

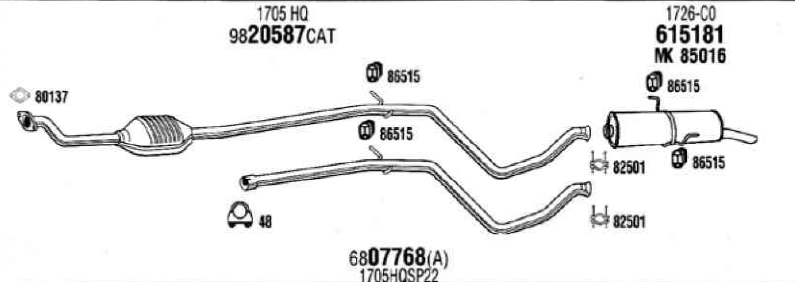

● En desarrollo

Los nombres y números de primer equipo se utilizan solamente como referencia

7319072

IMPORTANTE:

Al pedir sistemas de escape, rogamos completen la referencia comenzando por 'MFO.' (ejemplo: 381394 → MFO.381394)
Pour commander echappement, nous vous prions de compléter la référence en commençant par MFO..
When ordering exhaust, please complete the reference by beginning with MFO..

ESCAPE / ECHAPPEMENT / EXHAUST

Fonos

Peugeot

MOTOR / MOTEUR / ENGINE

1705GW
9220734CAT

1726 CD
615181
MK 85016

80137 86515 86515 82501 86515 82501 48

6807768(A)
1705HQSP22

7319072

306
1.9 Diesel
05/99-02
1868 cc - 69 HP - 51 kW
Mot/Eng: DW8-DW8B
(A) Repair pipe Cat
Type/Typ: 7EWJ*-7TWJ*
Emission: Euro III

PE30699 **CAT**

1705 EZ
9220589CAT(A)

1717-49
615225
MK 85464

1726 T5
615409

86125 86119 83181 86119 83181 82516 86515 86515 82516 86515

306
2.0 HDi
08/98-05/01
1997 cc - 90 HP - 66 kW
Mot/Eng: DW10TD
(A)= Depol CEE 95
Type/Typ: 7ERH*

PE30685 **CAT**

1705 WD
6221810
MK 85288

1731 A2
9220275CAT(A)

1717 38
613113(A)
MK 85289

1726 C4
615447(C)
MK 85695

81187 82587 86119 86119 82501 86515 86515 82501 86515 615868(D) 86515

MK 21644
9220245CAT(B)
1731 96

MK 85289
613868(B)
1717-A1

● 615868(D)
1726 FQ

87854 87912 87854 87919

306
Cabrio
1.6i Autom.
05/97-05/01
1587 cc - 90 HP - 66 kW
Mot/Eng: TU5JP
(A)= Depol. CEE95 (B)= Depol. D3
(C)= -04/99 (D)= -04/99-
Type/Typ: 7DN* - TSN: 789-840
λ¹=05/97-06/98 Depol. EURO95/EURO96
λ²=07/98-05/01

PE30654 **CAT**

1705 FF
N.D.CAT

1731 H7
9220336CAT(A)

1717-A1
613868
MK 85289

1726 C4
615447
MK 85695

82598 82598 82587 82501 86515 86515 82501 86515

MK 21644
9220245CAT(B)
1731 96

87854 87919

306
Cabrio
1.6i Autom.
05/99-05/01
1587 cc - 90 HP - 66 kW
Mot/Eng: TU5JP
(A)= Depol. CEE95 (B)= Depol. D3
Type/Typ: 7DN*
TSN: 789-840
λ¹=Exc. Depol CEE 2000

PE30688 **CAT**

1731 L9
N.D.CAT

1717 N7
613403(A)

1726 JY
N.D.

86119 86119 82567 86515 86515 86019 86515

613754(B)
1717K4

306
Cabrio
1.6i
07/00-
1587 cc - 98 HP - 72 kW
Mot/Eng: TU5J
Depol. L4
(A) Autom. - (B) Autom
Type/Typ: 7DN*
TSN: 789-840

PE30689 **CAT**

1705 T9
9219790CAT
MK 19278

1717 38
613113
MK 85289

1726 C4
615447
MK 85695

86119 82563 86119 82501 86515 86515 82501 86515

306
Cabrio
1.8i
05/97-04/99
1761 cc - 101 HP - 74 kW
Mot/Eng: XU7JP
Type/Typ: TDLF74

PE30690 **CAT**

Los nombres y números de primer equipo se utilizan solamente como referencia

● En desarrollo

IMPORTANTE:

Al pedir sistemas de escape, rogamos completen la referencia comenzando por 'MFO.' (ejemplo: 381394 → MFO.381394)
 Pour commander echappement, nous vous prions de compléter la référence en commençant par MFO..
 When ordering exhaust, please complete the reference by beginning with MFO..

Peugeot

306
Cabrio
 1.8i 16v
04/97-02/02
 1761 cc - 110 HP - 81 kW
 Mot/Eng: XU7JP4
 Type/Typ: 7DLF*

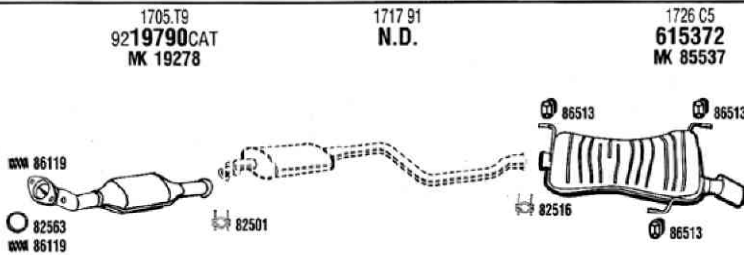

PE85030 **CAT**

306
Cabrio
 2.0i
10/93-
 1998 cc - 123 HP - 90 kW
 Mot/Eng: XU10J2
 Type/Typ: 7DR6D2, 7DRFX2/4
 λ¹-10/93->02/95
 λ²-03/95->04/97

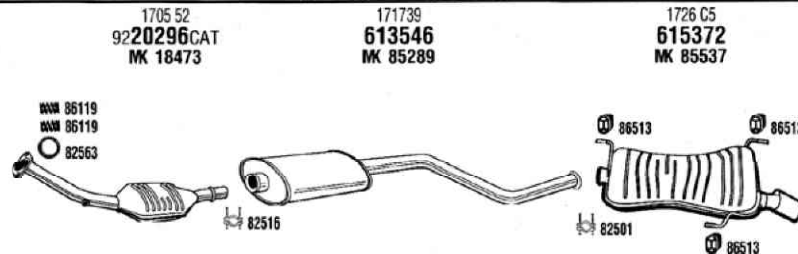

PE30660 **CAT**

306
Cabrio
 2.0i
10/93-04/97
 1998 cc - 135 HP - 99 kW
 Mot/Eng: XU10J4R
 (A)- Autom. - (B)- Autom.
 Type/Typ: 7DR6*, 7DRF*
 λ¹-10/93->02/95
 λ²-03/95->04/97

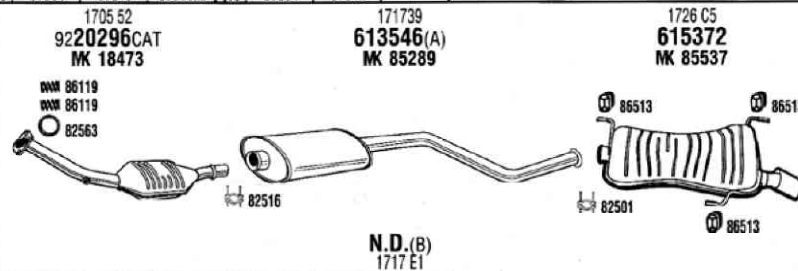

PE30661 **CAT**

307
Hatchback
 1.4
08/00-
 1360 cc - 75 HP - 55 kW
 Mot/Eng: KFW, K6D (TU3JP)
 Type/Typ: 3AVC

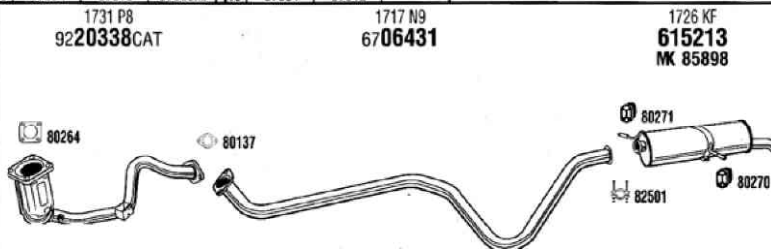

PEW30730 **CAT**

307
Hatchback
 1.4 16v
11/03-
 1360 cc - 88 HP - 65 kW
 Mot/Eng: KFU (ET3J4)
 Type/Typ: 3AVC

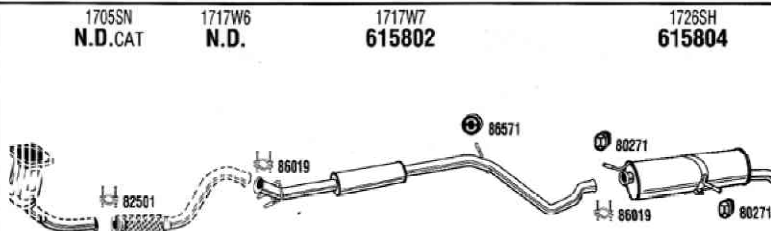

PEW30731 **CAT**

307
Hatchback
 1.6 16v
08/00-
 1587 cc - 109 HP - 80 kW
 Mot/Eng: NFU, NGA (TU5JP4)
 Type/Typ: 3AVC
 Mot/Eng: (A) NFU (TU5JP4)
 Mot/Eng: (B) NGA (TU5JP4)
 Emission: (A) Euro 2000

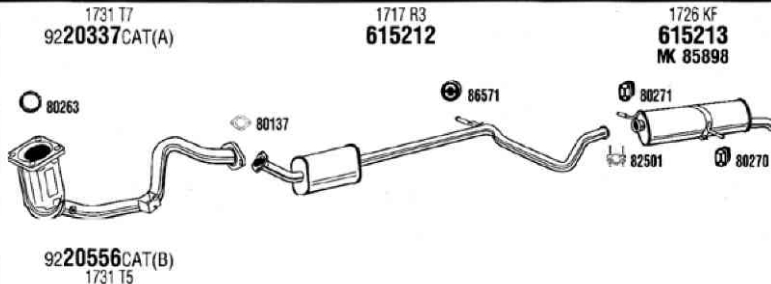

PEW30732 **CAT**

● En desarrollo

Los nombres y números de primer equipo se utilizan solamente como referencia

IMPORTANTE:

Al pedir sistemas de escape, rogamos completen la referencia comenzando por 'MFO.' (ejemplo: 381394 → MFO.381394)
 Pour commander echappement, nous vous prions de compléter la référence en commençant par MFO..
 When ordering exhaust, please complete the reference by beginning with MFO..

ESCAPE / ECHAPPEMENT / EXHAUST

Fonos

Peugeot

1731 R2 92 20586 CAT	1717 P6 615215	1726 KX 615210 MK 85899
--------------------------------	--------------------------	--------------------------------------

307
Hatchback
2.0 16v
08/00-
1997 cc - 136 HP - 100 kW
Mot/Eng: RFN (EW10J4)
Type/Typ: 3A/C

PEW30733 **CAT**

1731R8 91 20632 CAT	1705 LH 61 06434	1717 P8 67 06432	1726 KQ 615214 MK 85898
-------------------------------	----------------------------	----------------------------	--------------------------------------

307
Hatchback
1.4 HDi
10/01-
1398 cc - 68 HP - 50 kW
Mot/Eng: 8HZ, 8HX (DV4TD)
Type/Typ: 3A/C

PEW30734 **CAT**

1705ZS ● 91 20693 CAT	1705ZR 61 07967	1717Z9 67 08227	1726 KX 615211 MK 85899
---------------------------------	---------------------------	---------------------------	--------------------------------------

307
Hatchback
1.6 HDi
02/04-
1560 cc - 109 HP - 80 kW
Mot/Eng: 9HY (DV6TED4)
Type/Typ: 3A/C
W/ Particle Filter

PEW30735 **CAT**

1705 NQ 97 20344 CAT	1726 KX 615211 MK 85899
--------------------------------	--------------------------------------

66**07777**(A)
1705LASP22

307
Hatchback
2.0 HDi
08/00-
1997 cc - 90 HP - 66 kW
Mot/Eng: RHY (DW10TD)
Type/Typ: 3A/C
(A) Repair pipe

PEW30736 **CAT**

1705 LV N.D.	174006 N.D.CAT	1717 Q0 65 06433	1726 KX 615211 MK 85899
-----------------	-------------------	----------------------------	--------------------------------------

307
Hatchback
2.0 HDi
08/00-08/02
1997 cc - 107 HP - 79 kW
Mot/Eng: RHS (DW10ATED4)
Type/Typ: 3A/C
W/ Particle Filter

PEW30737 **CAT**

1705 LV N.D.	1731 Y6 N.D.CAT	174007 N.D.CAT	1717 Q0 65 06433	1726 KX 615211 MK 85899
-----------------	--------------------	-------------------	----------------------------	--------------------------------------

307
Hatchback
2.0 HDi
09/02-
1997 cc - 107 HP - 79 kW
Mot/Eng: RHS (DW10ATED4)
Type/Typ: 3A/C
W/ Particle Filter

PEW30738 **CAT**

Los nombres y números de primer equipo se utilizan solamente como referencia

● En desarrollo

IMPORTANTE:

Al pedir sistemas de escape, rogamos completen la referencia comenzando por 'MFO.' (ejemplo: 381394 → MFO.381394)
 Pour commander echappement, nous vous prions de compléter la référence en commençant par MFO..
 When ordering exhaust, please complete the reference by beginning with MFO..

Peugeot

307
Hatchback
 2.0 HDi
10/03-
 1997 cc - 136 HP - 100 kW
 Mot/Eng: RHR (DW10BTEd4)
 Type/Typ: 3A/C
W/ Particle Filter

1731GF
N.D.CAT

1717V2
6508214

1726 KX
615211
MK 85899



PEW30739 **CAT**

307
 (Break & SW)
 1.4
03/02-
 1360 cc - 75 HP - 55 kW
 Mot/Eng: KFW (TU3JP)
 Type/Typ: 3E

1731 P8
9220338CAT

1717 Q2
6808225

1726LK
615636
MK 85898



PEW30740 **CAT**

307
 (Break & SW)
 1.6 16v
03/02-
 1587 cc - 109 HP - 80 kW
 Mot/Eng: NFU (TU5JP4)
 Type/Typ: 3E
Transmission Type:(A) Autom.
Transmission Type:(B) Autom.

1731 T5
9220556CAT(A)

1717Q3
615277

1726LK
615636
MK 85898

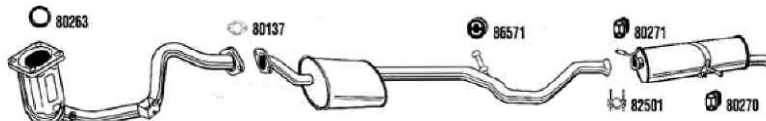

PEW30741 **CAT**

307
 (Break & SW)
 2.0 16v
03/02-
 1997 cc - 136 HP - 100 kW
 Mot/Eng: RFN (EW10J4)
 Type/Typ: 3E

9220337CAT(B)
 1731 I7

1717Q4
615618

1726KW
615622
MK 85899

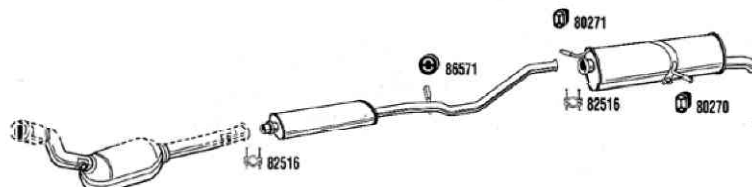

PEW30742 **CAT**

307
 (Break & SW)
 1.6 HDi
02/04-
 1560 cc - 109 HP - 80 kW
 Mot/Eng: 9HY (DV6TED4)
 Type/Typ: 3E
W/ Particle Filter

1705ZS 1705ZR
9120693CAT 6107967

1717Z8
N.D.

1726TJ
N.D.

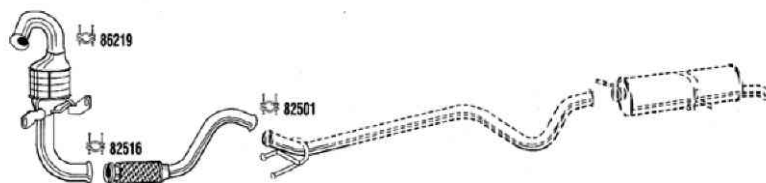

PEW30743 **CAT**

307
 (Break & SW)
 2.0 HDi
03/02-
 1997 cc - 90 HP - 66 kW
 Mot/Eng: RHY (DW10TD)
 Type/Typ: 3E
(A) Repair pipe

1705 QK
9720547CAT

1726KW
615622
MK 85899

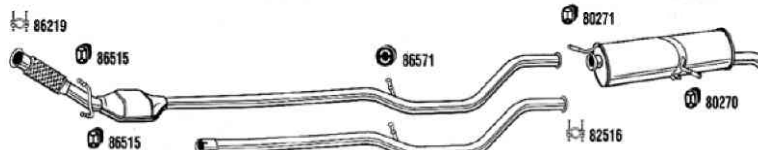

PEW30744 **CAT**

6608235(A)
 1705NRSP22

● En desarrollo

Los nombres y números de primer equipo se utilizan solamente como referencia

IMPORTANTE:

Al pedir sistemas de escape, rogamos completen la referencia comenzando por 'MFO.' (ejemplo: 381394 → MFO.381394)
 Pour commander echappement, nous vous prions de compléter la référence en commençant par MFO..
 When ordering exhaust, please complete the reference by beginning with MFO..

ESCAPE / ECHAPPEMENT / EXHAUST

Fonos

1705 LV N.D.	174006 N.D.CAT	1717 T4 6508216	1726KW 615622 MK 85899
-----------------	-------------------	--------------------	------------------------------

307
 (Break & SW)
 2.0 HDi
03/02-08/02
 1997 cc - 107 HP - 79 kW
 Mot/Eng: RHS (DW10ATED4)
 Type/Typ: 3E
 W/ Particle Filter

PEW30745 **CAT**

1705 LV N.D.	1731 Y6 N.D.CAT	174007 N.D.CAT	1717 T4 6508216	1726KW 615622 MK 85899
-----------------	--------------------	-------------------	--------------------	------------------------------

307
 (Break & SW)
 2.0 HDi
09/02-
 1997 cc - 107 HP - 79 kW
 Mot/Eng: RHS (DW10ATED4)
 Type/Typ: 3E
 W/ Particle Filter

PEW30746 **CAT**

1731AL N.D.CAT(A)	1717CH 6508215(C)	1726KW 615622 MK 85899
----------------------	----------------------	------------------------------

307
 (Break & SW)
 2.0 HDi
02/04-
 1997 cc - 136 HP - 100 kW
 Mot/Eng: RHR (DW10BTED4)
 Type/Typ: 3E
 To:(A) -07/04 - From:(B) 07/04-
 To:(C) -05/04 - From:(D) 05/04-
 W/ Particle Filter

PEW30747 **CAT**

N.D.CAT(B) 1731GF	N.D.(D) 1717V1	1726QY 615803
----------------------	-------------------	------------------

307 CC
 Cabrio
 2.0 16v
10/03-
 1997 cc - 136 HP - 100 kW
 Mot/Eng: RFN (EW10J4)
 Type/Typ: 3E
 Transmission Type:(A) Autom.
 Transmission Type:(B) Autom.

PEW30748 **CAT**

1703-88 31530	1726-62 61531 MK 85006
------------------	------------------------------

309
 GE-GL-GR-SR-XA-XE-XL
 Chorus-Graffic-Profil
 1.1
07/85-08/92
 1118 cc - 54 HP - 40 kW
 Mot/Eng: E1A
 Type/Typ: 1DAE11/AE12/AG12/CE11/CG12
 Type/Typ: 3AE1A2/CE1A2/AG1A2/CG1A2/SG1A
 TSN: 233-495

7312813 PE55001

1704-22 6213217	1728-84 6715486	1726-62 61531 MK 85006
--------------------	--------------------	------------------------------

309
 XA-XE-GE-Chorus
 1.1i
07/89-07/92
 1124 cc - 60 HP - 44 kW
 Mot/Eng: TU1
 Type/Typ: 3CH1A1/A2-3AH1A1/A2-3SH1A1/A2

7315487 PE55013

Los nombres y números de primer equipo se utilizan solamente como referencia

● En desarrollo

IMPORTANTE:

Al pedir sistemas de escape, rogamos completen la referencia comenzando por 'MFO.' (ejemplo: 381394 → MFO.381394)
 Pour commander echappement, nous vous prions de compléter la référence en commençant par MFO..
 When ordering exhaust, please complete the reference by beginning with MFO..

Peugeot

Fonos

309
Vital-B Line-Style
 1.1i
01/90-12/95
 1124 cc - 60 HP - 44 kW
 Mot/Eng: TU1M (Single Point Inj.)
 (A) repair pipe Cat
 Type/Typ: 3AHDZ2-3CHDZ2
 TSN: 650-673

1705 10
 6207180

1728-96
 9719176CAT
 MK 18471

1726-65
 61565
 MK 85006

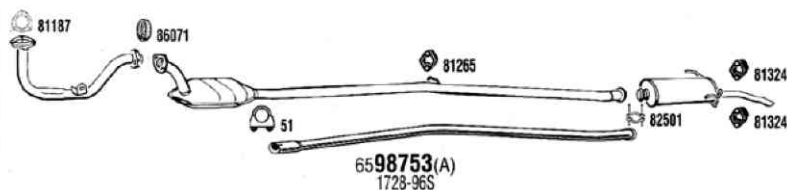

7315487

PE55041 **CAT**

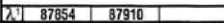

309
GE-GL-GR-XS-Graffic-Style
 1.1i
07/90-02/91
 1124 cc - 60 HP - 44 kW
 Mot/Eng: TU1M (Single Point Inj.)
 (A) repair pipe Cat
 Type/Typ: 3AHDZ2-3CHDZ2
 TSN: 650-673

1705 10
 6207180

1728-96
 9719176CAT
 MK 18471

1726-65
 61565
 MK 85006

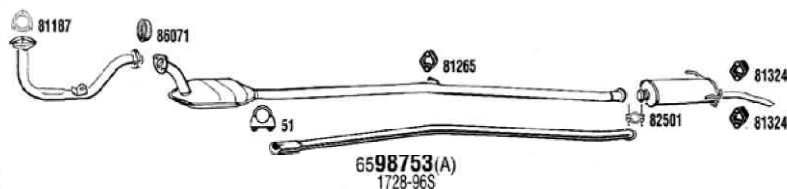

7315487

PE55036 **CAT**

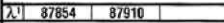

309
GE-GL-GR-SR-XE-XL
 1.3
07/85-10/90
 1294 cc - 64 HP - 47 kW
 Mot/Eng: G1A
 Type/Typ: 10AE11/AE12/AG12/CE11CG12
 Type/Typ: 3AE1A2/CE1A2/AG1A2/CG1A2/SG1A
 TSN: 234-496

1703-88
 31530

1726-62
 61531
 MK 85006



7312813

PE55051

309
XL-GL-GR-Profil
 1.4
07/85-06/89
 1360 cc - 67 HP - 49 kW
 Mot/Eng: TU3A
 Type/Typ: 3CK1G2-3AK1G2
 TSN: 600-603

1704-80
 6215489

1728-79
 6715490

1726-41
 5315491¹
 MK 85009

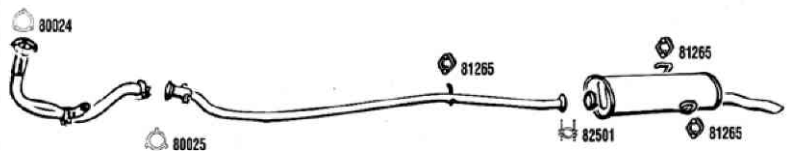

7315492

PE55015

309 (E)
XS-SX
 1.4i
04/89-
 1360 cc - 84 HP - 62 kW
 Mot/Eng: TU3S (Single Point Inj.)
 Type/Typ: 10CKZ2-10AKZ2

1704-80
 6215489

1728-78
 61564

1726-65
 61565
 MK 85006

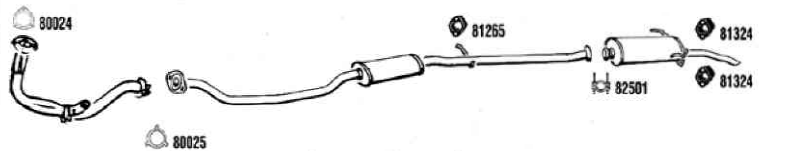

7315492

PE30900

309
XL-GL-GR-Profil-Green
 1.4
07/89-06/91
 1360 cc - 67 HP - 49 kW
 Mot/Eng: TU3A
 Type/Typ: 3CK1G2-3AK1G2-3SK1G2
 TSN: 612-622

1704-98
 6213222

1728-84
 6715486

1726-62
 61531
 MK 85006

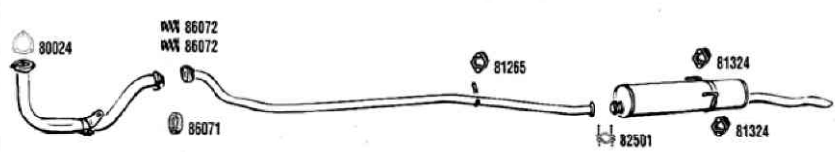

7315487

PE55014

● En desarrollo

Los nombres y números de primer equipo se utilizan solamente como referencia

IMPORTANTE:



Al pedir sistemas de escape, rogamos completen la referencia comenzando por 'MFO.' (ejemplo: 381394 → MFO.381394)
 Pour commander echappement, nous vous prions de compléter la référence en commençant par MFO..
 When ordering exhaust, please complete the reference by beginning with MFO..

ESCAPE / ECHAPPEMENT / EXHAUST

Fonos

Peugeot

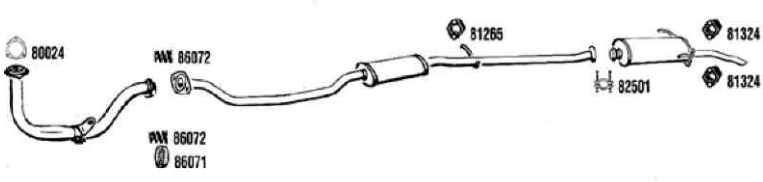
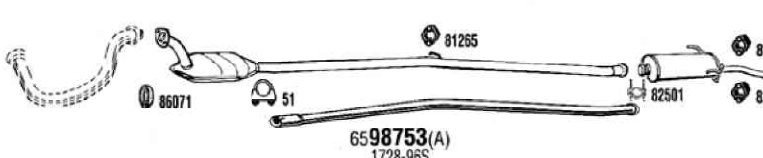
MOTOR / MOTEUR / ENGINE

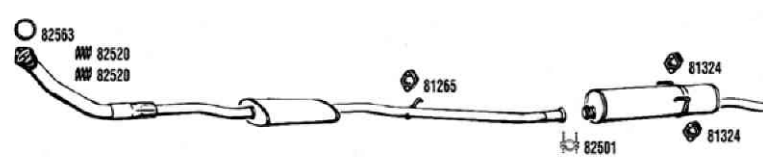
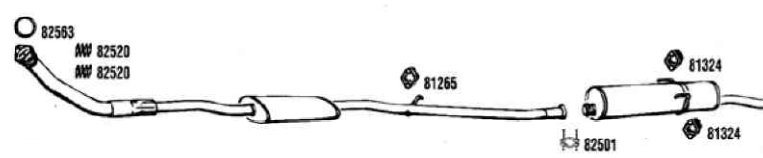
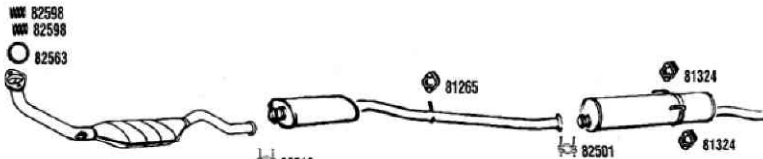
<p>1705-22 6217176</p> 	<p>1717-07 615281</p>	<p>1726-65 61565 MK 85006</p>	<p>309 GE-GL-XL-XS-GR-SX-GLX- Graffic-Green-Look-Profil 1.4 07/91-07/92 1360 cc - 75 HP - 55 kW Mot/Eng: TU3F2 Type/Typ: 3AK2D2-3CK2D2</p>
7315487			PE55025
<p>1704-73 N.D.</p> 	<p>1728-96 9719176CAT MK 18471</p>	<p>1726-65 61565 MK 85006</p>	<p>309 GR-SX-SR-GL-GLX-XE-XR-XS Graffic-Green-Profil 1.4i 02/90-02/91 1360 cc - 75 HP - 55 kW Mot/Eng: TU3M (Single Point Inj.) (A) repair pipe Cat Type/Typ: 10AKD2/Y2-10CKD2-3A/3CKDY2 TSN: 300-602-611-621</p>
7315487			PE55037 CAT
<p>1705-11 N.D.</p> 	<p>1728-96 9719176CAT MK 18471</p>	<p>1726-65 61565 MK 85006</p>	<p>309 GLX-GRX-XS-SX-Vital-Style 1.4i 02/91-94 1360 cc - 75 HP - 55 kW Mot/Eng: TU3M (Single Point Inj.) (A) repair pipe Cat Type/Typ: 3AKDY2-3CKDY2 TSN: 611-621</p>
7315487			PE55035 CAT
<p>1703-58 61534</p> 	<p>1726-62 61531 MK 85006</p>	<p>1726-62 61531 MK 85006</p>	<p>309 GR-SR-XR-XS-SX-GT-GTX 1.6, 1.6i 07/85-07/92 1580 cc - 75, 104 HP - 55, 76 kW Mot/Eng: XU51C, XU5JA Type/Typ: 10AB11/12/22/31-10AD22/-3AD2H2 Type/Typ: 10CB11/12/14/22/31-3CD2H2 TSN: 216-236-497-606</p>
7312814			PE55011
<p>1703-58 61534</p> 	<p>1726-62 61531 MK 85006</p>	<p>1726-62 61531 MK 85006</p>	<p>309 XS-GR-SX-GT-GTX 1.6i 07/88-07/92 1580 cc - 104 HP - 76 kW Mot/Eng: XU52C (Single Point Inj.) Type/Typ: 10AB22-10CB22-3AD2H2-3CD2H2 TSN: 216-236</p>
7312814			PE55016
<p>1704-62 9218356CAT MK 18472</p> 	<p>1728-43 615644 MK 85737</p>	<p>1726-62 61531 MK 85006</p>	<p>309 GL-GR-GLX-GRX-SX-XS-GT 1.6 (incl. Autom.), 1.6i 09/88- 1580 cc - 75, 89 HP - 55, 65 kW Mot/Eng: XU52C-XU5M (F) 07/92- Type/Typ: 3ARDY2/4-3CBDY2/4-3CBDZ2 TSN: 244-246-615-625</p>
7314641			PE55032 CAT

Los nombres y números de primer equipo se utilizan solamente como referencia

● En desarrollo

IMPORTANTE:

Al pedir sistemas de escape, rogamos completen la referencia comenzando por 'MFO.' (ejemplo: 381394 → MFO.381394)

Pour commander echappement, nous vous prions de compléter la référence en commençant par MFO..

When ordering exhaust, please complete the reference by beginning with MFO..

Peugeot

Fonos

309
GR-SR-GT-SX-XS-XR-GTX
 1.9, 1.9i
07/85-07/92
 1905 cc - 92, 102 HP - 68, 75 kW
 Mot/Eng: XU92-XU92C
 Type/Typ: 10AB11/12/14/31-3AD2A2-3CD2A2
 Type/Typ: 10CB11/12/14/22/31-10AD22

1703-58
61534

1726-62
61531
 MK 85006

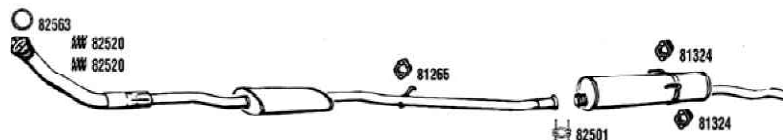

7312874

PE30906

309
 1.9 GTI 8v
12/86-07/92
 1905 cc - 128 HP - 94 kW
 Mot/Eng: XU9JA
 Type/Typ: 10CD62-10AD62-3CDB6B2-3ADB6B2
 TSN: 240

1704-18
61561

1726-57
61562
 MK 85006



7312814

PE55021

309
 1.9 GTI 16v
07/89-07/92
 1905 cc - 160 HP - 118 kW
 Mot/Eng: XU9JA
 ch.no. 10000001-
 Type/Typ: 3CD6C2

1704-97
816294¹

1726-55
 52**16295¹**
 MK 85006

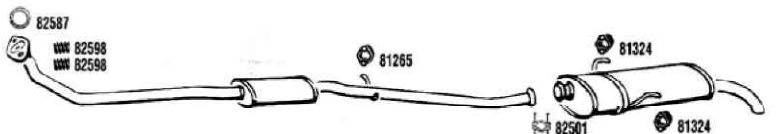

7315496

PE55019

309
GL-GR-GT-GTI
 1.9i
09/86-12/89
 1905 cc - 98, 105 HP - 72, 77 kW
 Mot/Eng: XU9J1
 Type/Typ: 10A-10C
 TSN: 220-238-619-609

1704-62
 92**18356**CAT
 MK 18472

1728-43
615644
 MK 85737

1726-62
61531
 MK 85006

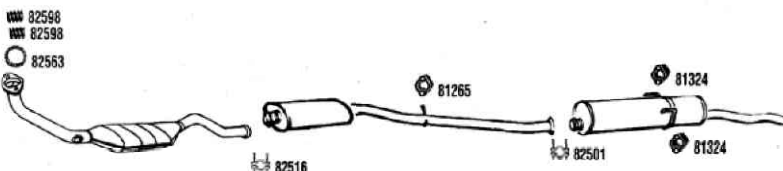

7314641

PE55012

CAT

λ 1 87854 87910

309
GR-GT-SX-XR-XS-GTI
 1.9i 8v
01/89-11/93
 1905 cc - 120 HP - 88 kW
 Mot/Eng: XU9M-XU9JAZ
 Type/Typ: 10ADD2/CDD2/CDK2/ADK2-
 Type/Typ: 3AD0Z2/CDDZ2/ADKZ/CDKZ2
 TSN: 288-289-290-291-608-
 TSN: 610-620-647

1704-62
 92**18356**CAT
 MK 18472

1728-73
615236
 MK 85737

1726-57
61562
 MK 85006

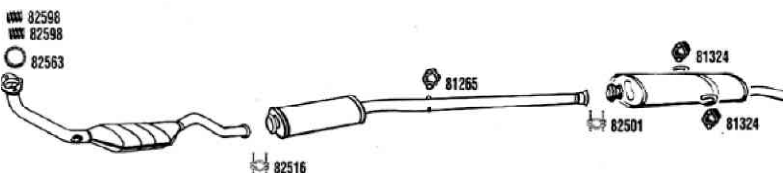

7314641

PE55033

CAT

λ 1 87854 87910

309
 1.9 GTI 16v
07/90-11/93
 1905 cc - 147 HP - 108 kW
 Mot/Eng: XU9J42
 Type/Typ: 3CFW2-3CDFW2
 TSN: 672

1705-26
N.D.CAT

1717-12
 65**18032¹**
 MK 85737

1726-55
 52**16295¹**
 MK 85006

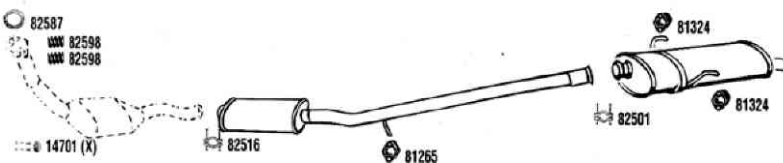

7315496

PE55047

CAT

λ 1 87854 87910

● En desarrollo

Los nombres y números de primer equipo se utilizan solamente como referencia

IMPORTANTE:

Al pedir sistemas de escape, rogamos completen la referencia comenzando por 'MFO.' (ejemplo: 381394 → MFO.381394)
 Pour commander echappement, nous vous prions de compléter la référence en commençant par MFO..
 When ordering exhaust, please complete the reference by beginning with MFO..

ESCAPE / ECHAPPEMENT / EXHAUST

Fonos

Peugeot

MOTOR / MOTEUR / ENGINE

1721-28 613509	1703-94 31540	1726-62 61531 MK 85006
-------------------	------------------	------------------------------

7313485

309
GLD-GRD-SRD-XLD-XRD
1.8 Diesel
10/86-11/93
1769 cc - 60 HP - 44 kW
Mot/Eng: XUD7
Type/Typ: 10AA92/AD52/AD91/AD92/CA92-
Type/Typ: 10CD91/CD92/SA92/SD92-3CA9A2/9
PE55048

1704-91 61549	1726-57 61562 MK 85006
------------------	------------------------------

7315496

309
SRD-GLD-XSD
1.8 TD
07/89-11/93
1769 cc - 78 HP - 57 kW
Mot/Eng: XUD7TE
ch.no. 10000001-
Type/Typ: 3AA8B2-3CA8B2
PE55018

1721-28 613509	1703-94 31540	1726-62 61531 MK 85006
-------------------	------------------	------------------------------

7313485

309
GLD-GRD-XLD-XRD-XAD-SRD
1.9 Diesel
09/86-11/93
1905 cc - 64 HP - 47 kW
Mot/Eng: XUD9
Type/Typ: 10AA92/AD92/CD92/SD92-
Type/Typ: 3CD9A2-3SD9A2-3CA9A9-3SA9A2
TSN: 221-239-607-617-646-668
PE55003

1721-28 613509	N.D.CAT	1717-10 6418033	1726-62 61531 MK 85006
-------------------	---------	--------------------	------------------------------

7318034

309
GRD-XRD-XAD-SRD-Graffic
1.9 Diesel
07/91-11/93
1905 cc - 64 HP - 47 kW
Mot/Eng: XUD9
Type/Typ: 3AD9A2/JJ2-3CD9A2/JJ2-3SA9A2
TSN: 646-688
PE55050

CAT

1701-29 6101281 ¹	1720-02 5101282 ¹	1722-01 6601283(A)	1724-13 615384(A)
---------------------------------	---------------------------------	-----------------------	----------------------

N.D.(B)
1722-02

6508539(B)
1724-14

403
01/55-12/66
(A)
(B) -U-5
PE40302

1701-29 6101281 ¹	1720-02 5101282 ¹	1722-03 N.D.	1724-16 6801286 ¹
---------------------------------	---------------------------------	-----------------	---------------------------------

403 - 403 Diesel
01/55-12/66
850-1050 kg
Type/Typ: U 8
PE40303

Los nombres y números de primer equipo se utilizan solamente como referencia

● En desarrollo

IMPORTANTE:

Al pedir sistemas de escape, rogamos completen la referencia comenzando por 'MFO.' (ejemplo: 381394 → MFO.381394)
Pour commander echappement, nous vous prions de compléter la référence en commençant par MFO..
When ordering exhaust, please complete the reference by beginning with MFO..

Peugeot

Fonos

404

 Cabrio

1.6

01/68-12/75

1618 cc - 72 HP - 53 kW

Mot/Eng: XC5-A8 Inj

1720-03
5101287

1701-64
N.D.

1720-10
5101302

1724-28
615294
MK 85163

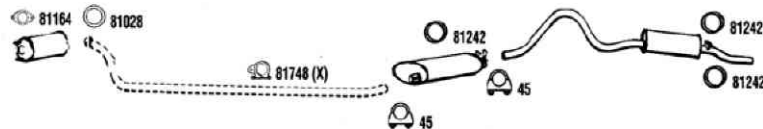

PE40313

404

 Cabrio-Coupé

1.6, 1.6i

01/68-12/75

1618 cc - 72, 96 HP - 53, 71 kW

Mot/Eng: XC6

 BA7

1701-63
N.D.

1722-08
N.D.

1720-10
5101302

1724-28
615294
MK 85163

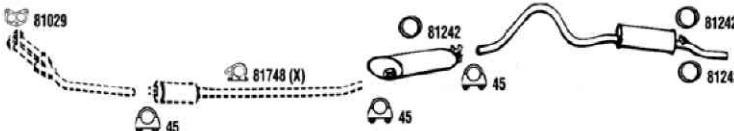

PE40314

404

68-75

 BA7

Inj.

1701-63
N.D.

1722-08
N.D.

1720-10
5101302

1724-28
615294
MK 85163

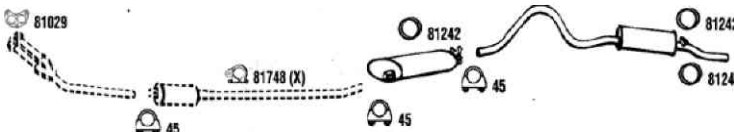

PE40317

404



1.6

01/67-12/75

1618 cc - 72 HP - 53 kW

Mot/Eng: XC7

Type/Typ: U8-U10

1720-03
5101287

1701-58
6701318

1732-34
615319
MK 85843



PE40328

404



2.0 Diesel

01/67-12/75

1948 cc - 57 HP - 42 kW

Mot/Eng: XDB8

 BA7-C3

N.D.

1720-08
N.D.

1724-28
615294
MK 85163

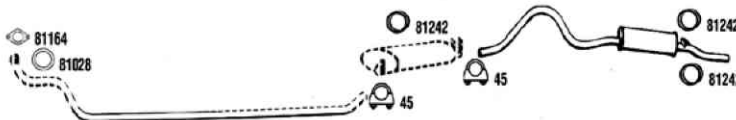

PE40319

404



2.0 Diesel

01/67-12/75

1948 cc - 57 HP - 42 kW

Mot/Eng: XDB8

Type/Typ: U 8-U10

1701-59
6801321

1732-34
615319
MK 85843

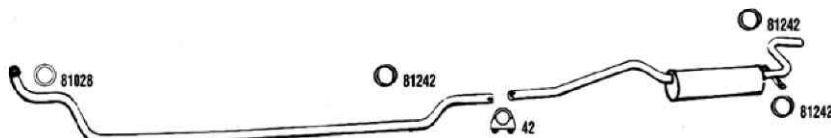

PE40329

● En desarrollo

Los nombres y números de primer equipo se utilizan solamente como referencia

IMPORTANTE:

Al pedir sistemas de escape, rogamos completen la referencia comenzando por 'MFO.' (ejemplo: 381394 → MFO.381394)

Pour commander echappement, nous vous prions de compléter la référence en commençant par MFO..

When ordering exhaust, please complete the reference by beginning with MFO..

ESCAPE / ECHAPPEMENT / EXHAUST

Peugeot

Fonos

1704-26 6213225	1721-83 6213226	1721-84 615327	1726-56 61547 MK 85006
--------------------	--------------------	-------------------	------------------------------

7313567

405
GL
1.4
07/87-07/92
1360 cc - 75 HP - 55 kW
Mot/Eng: TU32-TU3A
Type/Typ: 15B11-15B11/1-15B12

1706-29 N.D.	1717-13 ● 9220754CAT	1728-91 61546 MK 85737	1726-56 61547 MK 85006
-----------------	-------------------------	------------------------------	------------------------------

7318035

405
GL-GR-Style
1.4i 8v
07/92-97
1360 cc - 75 HP - 55 kW
Mot/Eng: TU3M/Z-FM/MC (Single P. Inj.)
Type/Typ: 4BKDX2-4EKDX2
TSN: 709-715

1704-35 31545	1728-91 61546 MK 85737	1726-56 61547 MK 85006
------------------	------------------------------	------------------------------

7313568

PE40528
405
GL-GR-Style
1.4i 8v
07/92-97
1360 cc - 75 HP - 55 kW
Mot/Eng: TU3M/Z-FM/MC (Single P. Inj.)
Type/Typ: 4BKDX2-4EKDX2
TSN: 709-715

PE40548 **CAT**

405
GL-GR-SR-GLX
1.6
07/87-06/90
1580 cc - 92 HP - 68 kW
Mot/Eng: XU52C
ch.no. 8000001-
Type/Typ: 15B22-15EB22

1705-05 6215958	1728-91 61546 MK 85737	1726-56 61547 MK 85006
--------------------	------------------------------	------------------------------

7313568

PE40512
405
GL-GR-SR
1.6
07/90-07/92
1580 cc - 92 HP - 68 kW
Mot/Eng: XU52C
Type/Typ: 15B22/24/52-15EB22/24/52

1704-90 9219771CAT MK 18473	1704-90S 7198754(A)	1728-91 61546 MK 85737	1726-56 61547 MK 85006
-----------------------------------	------------------------	------------------------------	------------------------------

7313568

PE40529
405
GL-GR
1.6i
07/87-07/92
1580 cc - 72 HP - 53 kW
Mot/Eng: XU51C
ch.no. S800001-S8211486
(A) repair pipe Cat
Type/Typ: 15B12-15BD12-15EB12
TSN: 261-272

1704-90 9219771CAT MK 18473	1704-90S 7198754(A)	1728-91 61546 MK 85737	1726-56 61547 MK 85006
-----------------------------------	------------------------	------------------------------	------------------------------

7313568

PE40523 **CAT**

405
GLi-GRi-SRi
1.6i 8v incl. Autom.
01/88-06/92
1580 cc - 89 HP - 65 kW
Mot/Eng: XU5M (Single Point Inj.)
(A) repair pipe Cat
Type/Typ: 15BBD1/2/4-15EBD1/2/4-
Type/Typ: 4BBDY2/4-4EBDY2/4-4SBDY2
TSN: 629-632

Los nombres y números de primer equipo se utilizan solamente como referencia

● En desarrollo

IMPORTANTE:

Al pedir sistemas de escape, rogamos completen la referencia comenzando por 'MFO.' (ejemplo: 381394 → MFO.381394)
Pour commander echappement, nous vous prions de compléter la référence en commençant par MFO..
When ordering exhaust, please complete the reference by beginning with MFO..

MOTOR / MOTEUR / ENGINE

Peugeot

405

GR-GLI-GRI-SR 

1.6i 8v incl. Autom.

07/92-97

1580 cc - 89 HP - 65 kW
 Mot/Eng: XU5M, XU5JP (Single Point Inj.)
 (A) repair pipe Cat - TSN: 704-712
 Type/Typ: 4BBDY2/4-4BBFZ2/4- 4EBFZ2-4SBF
 λ¹=07/92->06/95 λ²=07/95->00/97

1704-90 9219771CAT MK 18473	1704-90S 7198754(A)	1728-91 61546 MK 85737	1726-56 61547 MK 85006
-----------------------------------	------------------------	------------------------------	------------------------------

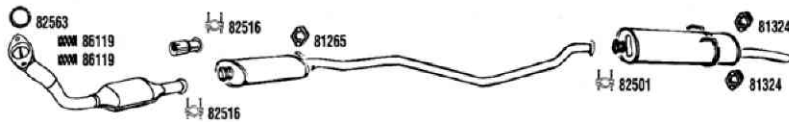

PE40544 CAT

λ¹	87854	87910	87999x2	λ²	87854	87912	87999
----	-------	-------	---------	----	-------	-------	-------

405

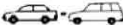
GL-GLX-GR-GRI 

1.8i 8v incl. Autom.

07/92-96

1762 cc - 101 HP - 74 kW
 Mot/Eng: XU7JP (Multi Point Inj.)
 (A) repair pipe Cat - TSN: 705-713
 Type/Typ: 4BLFZ2-4BLFZ4-4ELFZ2-4ELFZ4
 λ¹=07/92->06/95 - λ²=07/95->00/96

1705-31 9220126CAT MK 21682	1704-90S 7198754(A)	1728-91 61546 MK 85737	1726-56 61547 MK 85006
-----------------------------------	------------------------	------------------------------	------------------------------



PE40546 CAT

λ¹	87854	87910	87999x2	λ²	87854	87912	87999
----	-------	-------	---------	----	-------	-------	-------

7318035

405

GTX-GRI-SRI 

1.9i incl. Autom.

07/87-06/90

1905 cc - 125 HP - 92 kW
 Mot/Eng: XU9J2 ((L3.1 Jetronic)
 ch.no. 8000001-
 Type/Typ: 15BD62/64-15ED62/64

1705-06 615961	1728-63 61543 MK 85465	1726-31 61544 MK 85088
-------------------	------------------------------	------------------------------

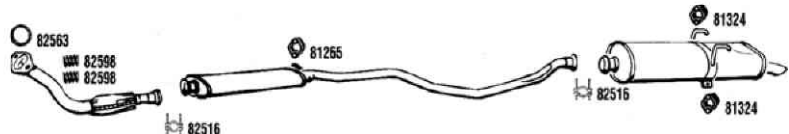

PE40514

7313569

405

GL-GR-SR 

1.9 incl. Autom.

07/87-06/90

1905 cc - 110 HP - 81 kW
 Mot/Eng: XU92C
 ch.no. 8000001 -
 Type/Typ: 15BD22-15BD24-14ED22-15ED24

1704-35 31545	1728-91 61546 MK 85737	1726-56 61547 MK 85006
------------------	------------------------------	------------------------------

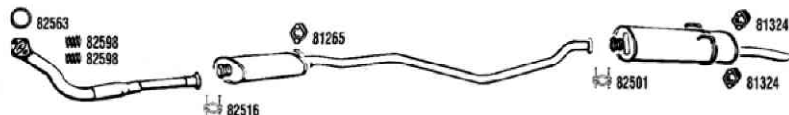

PE40513

7313568

405

GR-SR 

1.9 incl. Autom.

07/90-07/92

1905 cc - 110 HP - 81 kW
 Mot/Eng: XU92C
 Type/Typ: 15R27-15RD24-15ED22-15ED24
 TSN: 656

1705-05 6215958	1728-91 61546 MK 85737	1726-56 61547 MK 85006
--------------------	------------------------------	------------------------------



PE40530

7313568

405

GR-SR 

1.9

07/87-12/88

1905 cc - 95 HP - 70 kW
 Mot/Eng: XU92C
 (A) repair pipe CAT
 Type/Typ: 15 ED22-15ED24
 TSN: 262-274-651-677

1704-90 9219771CAT MK 18473	1704-90S 7198754(A)	1728-91 61546 MK 85737	1726-56 61547 MK 85006
-----------------------------------	------------------------	------------------------------	------------------------------



PE40525 CAT

λ¹	87854	87910
----	-------	-------

● En desarrollo

Los nombres y números de primer equipo se utilizan solamente como referencia

IMPORTANTE:

Al pedir sistemas de escape, rogamos completen la referencia comenzando por 'MFO.' (ejemplo: 381394 → MFO.381394)

Pour commander echappement, nous vous prions de compléter la référence en commençant par MFO..

When ordering exhaust, please complete the reference by beginning with MFO..

ESCAPE / ECHAPPEMENT / EXHAUST

Fonos 2007

Peugeot

MOTOR / MOTEUR / ENGINE

1704-58 92 19769 CAT MK 18473	1728-65 615258 MK 85465	1726-31 61544 MK 85088			
<table border="1"> <tr> <td>87854</td> <td>87910</td> <td>87999</td> </tr> </table>			87854	87910	87999
87854	87910	87999			

405
GLI-GRI-SRI
1.9i 8v incl. Autom.
06/88-08/92
1905 cc - 109 HP - 80 kW
Mot/Eng: XU9M
Type/Typ: 15RDD2/F2/F4/K2/K4
Type/Typ: 15EDD2/F2/F4/K2/K4
TSN: 281-283-656-657-678-679

7317160 PE40550 **CAT**

1705-06 615961	1728-93 615111 MK 85465	1726-31 61544 MK 85088			
<table border="1"> <tr> <td>87854</td> <td>87910</td> <td>87999</td> </tr> </table>			87854	87910	87999
87854	87910	87999			

405
Si-SRI-STI
1.9i incl. Autom.
07/90-07/92
1905 cc - 125 HP - 92 kW
Mot/Eng: XU9J2
Type/Typ: 15BD62-15BD64-15ED62-15ED64

7313569 PE40531

1704-58 92 19769 CAT MK 18473	1728-92 615235 MK 85465	1726-31 61544 MK 85088			
<table border="1"> <tr> <td>87854</td> <td>87910</td> <td>87999</td> </tr> </table>			87854	87910	87999
87854	87910	87999			

405
GRI-SRI-STI
1.9i
01/89-06/92
1905 cc - 120 HP - 88 kW
Mot/Eng: XU9JAZ
Type/Typ: 15BDK2/4-15EDK2/4
TSN: 282-284-658-680

7317160 PE40555 **CAT**

1704-58 92 19769 CAT(A) MK 18473	1728-92 615235 MK 85465	1726-31 61544 MK 85088			
<table border="1"> <tr> <td>87854</td> <td>87910</td> <td>87999</td> </tr> </table>			87854	87910	87999
87854	87910	87999			

405
GLI-GRI-SRI
1.9i
07/90-06/92
1905 cc - 105 HP - 77 kW
Mot/Eng: XU9J1/A (L-Jetronic)
(A) ch.no. J8143451-N7080000
Type/Typ: 15 BDF2/4-15 EDF2/4
TSN: 263-605

PE40552 **CAT**

1705-07 31596	1728-64 615641 MK 85465	1726-32 61558 MK 85088			
<table border="1"> <tr> <td>87854</td> <td>87910</td> <td>87999</td> </tr> </table>			87854	87910	87999
87854	87910	87999			

405
Mi16
1.9i 16v DOHC Excl.4x4
07/87-06/90
1905 cc - 158 HP - 116 kW
Mot/Eng: XU9J4 (Motronic)
ch.no. 8000001-
Type/Typ: 15BD621-15BD62C
TSN: 265

7313569 PE40517

1704-57 92 20090 CAT MK 21677	1728-64 615641 MK 85465	1726-32 61558 MK 85088			
<table border="1"> <tr> <td>87854</td> <td>87910</td> <td>87999x2</td> </tr> </table>			87854	87910	87999x2
87854	87910	87999x2			

405
Mi16
1.9i 16v DOHC Excl.4x4
07/87-06/90
1905 cc - 147 HP - 108 kW
Mot/Eng: XU9J4Z (Motronic)
Type/Typ: 15BDG2/1-15BDF2/1
TSN: 277-654-655

7317160 PE40527 **CAT**

Los nombres y números de primer equipo se utilizan solamente como referencia

● En desarrollo

IMPORTANTE:

Al pedir sistemas de escape, rogamos completen la referencia comenzando por 'MFO.' (ejemplo: 381394 → MFO.381394)
 Pour commander echappement, nous vous prions de compléter la référence en commençant par MFO..
 When ordering exhaust, please complete the reference by beginning with MFO..

Peugeot

Fonos

MOTOR / MOTEUR / ENGINE

405
Mi16 
 1.9i 16v DOHC Excl.4x4
07/90-97
 1905 cc - 158 HP - 116 kW
 Mot/Eng: XU9J4Z (Motronic)
 Type/Typ: 15BD62
 TSN: 265

1705-07 **31596** 1728-94 **615108** 1726-32 **61558**
 MK 85465 MK 85465 MK 85088

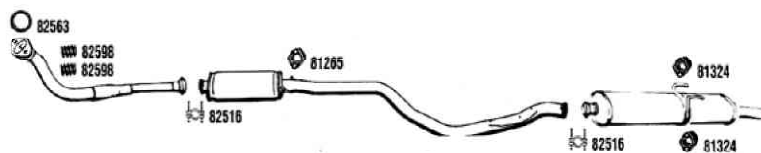

 **7313569**

PE40571

405
Mi16 
 1.9i 16v DOHC Excl.4x4
07/90-10/92
 1905 cc - 147 HP - 108 kW
 Mot/Eng: XU9J4Z (Motronic)
 Type/Typ: 15BD62/1-15BDF2/1
 TSN: 277-654-655

1704-57 **9220090CAT** 1728-94 **615108** 1726-32 **61558**
 NK 21677 MK 85465 MK 85088

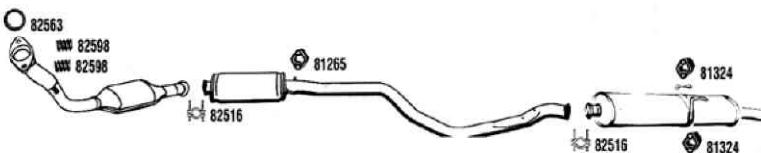

 **7317160**

PE40572 **CAT**

λ¹ 87854 87910 87999x2

405
GRI-SRI-STi 
 2.0i 8v incl. Autom. incl. 4x4
07/92-96
 1998 cc - 121 HP - 89 kW
 Mot/Eng: XU10J2 (Multi Point Inj.)
 Type/Typ: 4BRFX2/4 -4FRX2/4- 4ED2H2/4
 TSN: 706-707-714-715
 λ¹=07/92->06/95
 λ²=07/95->96

170532 **9220646CAT** 1717-14 **615114** 1726-74 **615115**
 NK 21677 MK 85465 MK 85170

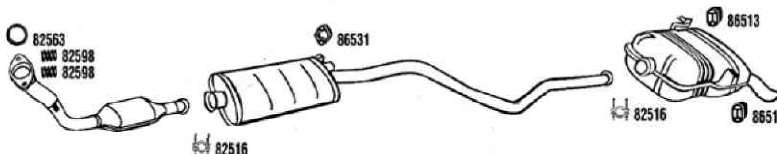

 **7318024**

PE40556 **CAT**

λ¹ 87854 87910 87999x2 λ² 87854 87912 87999

405
Mi16-Le Mans 
 2.0i 16v DOHC
07/92-96
 1998 cc - 152 HP - 112 kW
 Mot/Eng: XU10J4 (Motronic)
 Type/Typ: 4BRFY2
 TSN: 708
 λ¹=07/92->06/95
 λ²=07/95->96

1705-35 **N.D.CAT** 1717-14 **615114** 1726-74 **615115**
 NK 21677 MK 85465 MK 85170

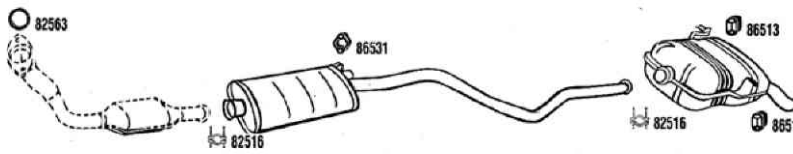

 **7318024**

PE40573 **CAT**

λ¹ 87854 87910 87999x2 λ² 87854 87912 87999

405
GRD-SRD-GTD 
 1.8 TD
03/88-07/92
 1796 cc - 90 HP - 66 kW
 Mot/Eng: XUD7TE
 Type/Typ: 15BA82-15EA82
 TSN: 270-275

1704-52 **6213681** 1728-95 **6613682** 1726-32 **61558**
 NK 21677 MK 85465 MK 85088

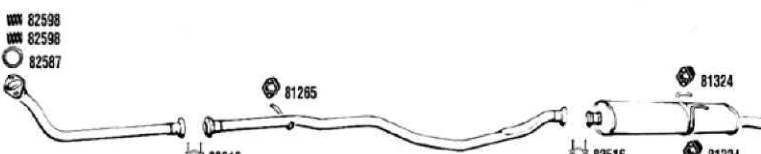

 **7313683**

PE40520

405
GRDT-SRDT 
 1.8 TD
07/90-06/92
 1769 cc - 90 HP - 66 kW
 Mot/Eng: XUD7TE
 Type/Typ: 115BAJ2-5EAJ2
 TSN: 270-275

1705-09 **9220668CAT** 1728-95 **6613682** 1726-32 **61558**
 NK 21677 MK 85465 MK 85088



 **7318040**

PE40575 **CAT**

● En desarrollo

Los nombres y números de primer equipo se utilizan solamente como referencia

IMPORTANTE:

Al pedir sistemas de escape, rogamos completen la referencia comenzando por 'MFO.' (ejemplo: 381394 → MFO.381394)
 Pour commander echappement, nous vous prions de compléter la référence en commençant par MFO..
 When ordering exhaust, please complete the reference by beginning with MFO..

ESCAPE / ECHAPPEMENT / EXHAUST

Fonos

Peugeot

MOTOR / MOTEUR / ENGINE

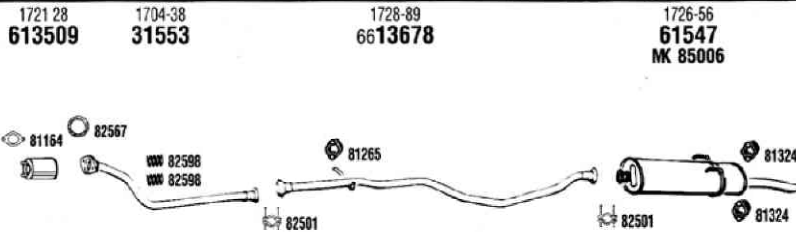

405
GLD-GRD-SRD
1.9 Diesel
07/87-11/96
1905 cc - 70 HP - 51 kW
Mot/Eng: XUD9A
ch.no. 8 000 001-
Type/Typ: 15B092/G92-15E092/G92-
Type/Typ: 15SB92-4EDGB2-4BDGB2
TSN: 264-273

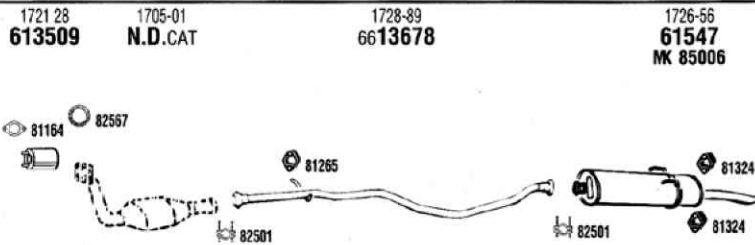

405
GLD-GRD
1.9 Diesel
07/89-11/96
1905 cc - 64, 68 HP - 47, 50 kW
Mot/Eng: XUD9, XUD9A
Type/Typ: 4EDJ2/Z2-4E/4BKDX2-4BDJ2/Z2
TSN: 659-682-710

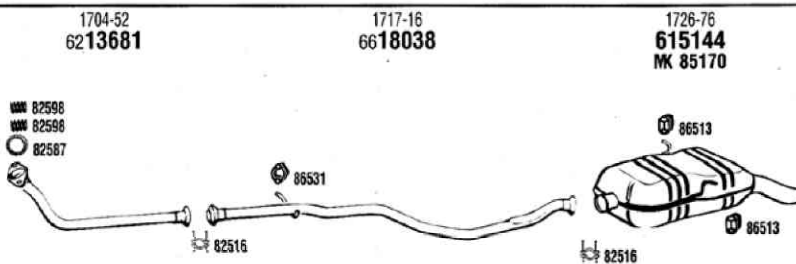

405
GRDT-SRDT
1.9 TD
07/92-97
1905 cc - 92 HP - 68 kW
Mot/Eng: XUD9TE
Type/Typ: 4BDBA2-4EDBA2

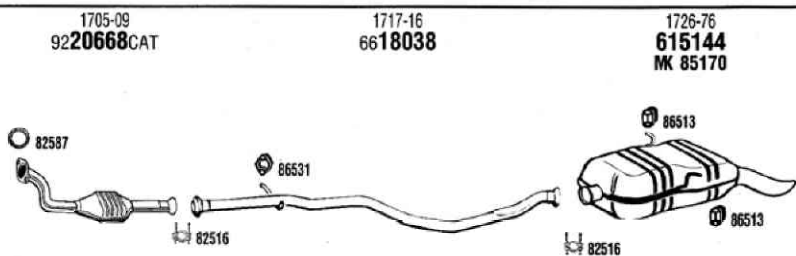

405
GRDT-SRDT
1.9 TD
07/92-97
1905 cc - 90 HP - 66 kW
Mot/Eng: XUD9TE
Type/Typ: 4BDHY2-4EDHY2
TSN: 703-711

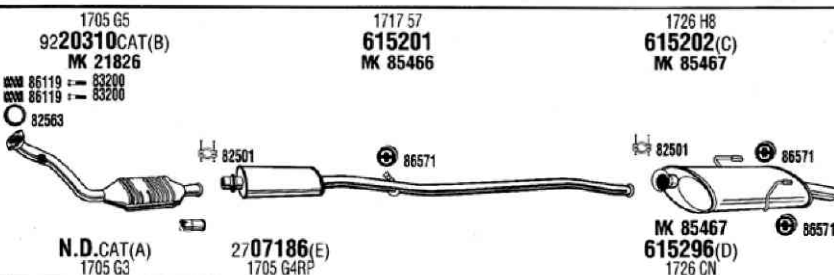

405
SL-SR-ST
1.6i
08/95-03/99
1580 cc - 90 HP - 66 kW
Mot/Eng: XU5JP
(A)= US-83 / CEE 19-5 - (B)= CEE 95-L3
(C) 05/95-04/99, (D) 05/99-12/99
(E) Repair pipe Cat 20310
Type/Typ: 8BBFZD-8BBFZE-8BBFZ2 - TSN: 769

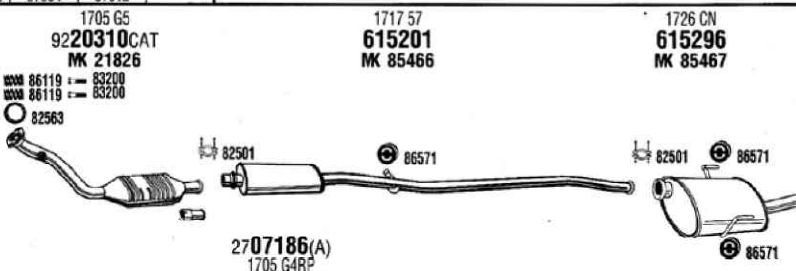

405

1.6i
04/99-
1580 cc - 90 HP - 66 kW
Mot/Eng: XU5JP
DEPOL CEE 95
(A) Repair pipe Cat 20310
Type/Typ: 8BB

Los nombres y números de primer equipo se utilizan solamente como referencia

● En desarrollo

IMPORTANTE:

Al pedir sistemas de escape, rogamos completen la referencia comenzando por 'MFO.' (ejemplo: 381394 → MFO.381394)
Pour commander echappement, nous vous prions de compléter la référence en commençant par MFO..
When ordering exhaust, please complete the reference by beginning with MFO..

Peugeot

Fonor

406
SL - SR - ST 
 1.8i
08/95-08/00
 1761 cc - 90,101 HP - 66,74 kW
 Mot/Eng: XU7JP
 (A) 08/95-04/99
 (B) 05/99-08/00
 Type/Typ: 8BL5A2-8BLFXE

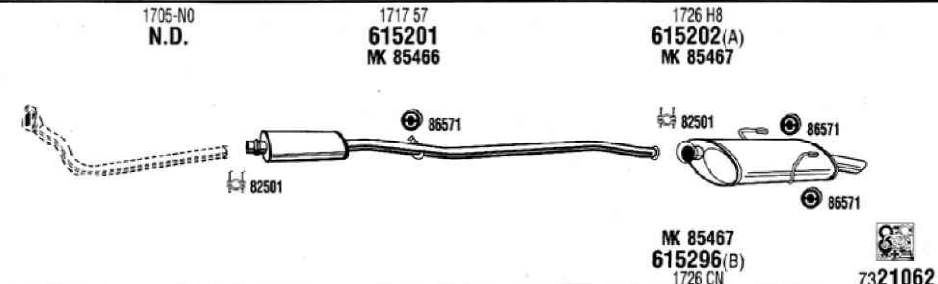

PE40609
406
SL-ST-SV-LX-GLX-SR 
 1.8i 16v
09/95-08/00
 1761 cc - 111 HP - 82 kW
 Mot/Eng: XU7JP4
 (A) Depol. US-63 / 19-5 / CEE 95
 (B) 09/95-04/99 - (C) 04/99-08/00
 (D) Repair pipe Cat 20310
 Type/Typ: 8BLF - TSN: 771

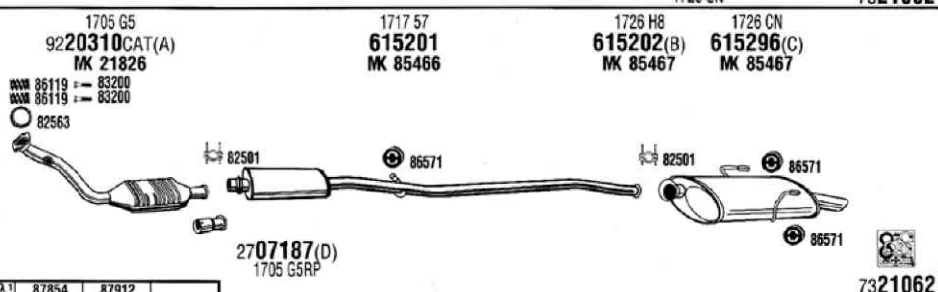

PE40602 **CAT**
406 
 1.8i 16v (LPG)
10/97-08/00
 1761 cc - 110 HP - 81 kW
 Mot/Eng: XU7JP4GPL
 (A) Depol. US-63 / 19-5 / CEE 95
 (B) -04/99 (C) 04/99- (D) Repair pipe Cat 20310
 Type/Typ: 8BLFYP-8BLFYE-8BLFYW - TSN: 771

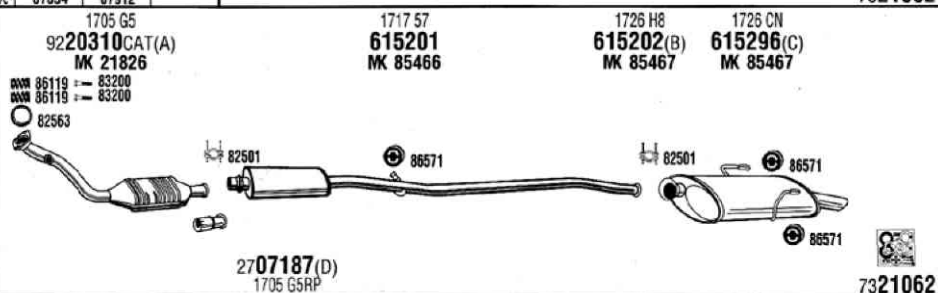

PE40631 **CAT**
406 
 1.8i 8v
10/96-12/99
 1761 cc - 90 HP - 66 kW
 Mot/Eng: XU7JB
 (A) 10/96-03/99 - (B) 04/99-12/99
 (C) Repair pipe Cat 20310
 Type/Typ: 8BLFXE - TSN: 856
 λ¹=10/96->12/96

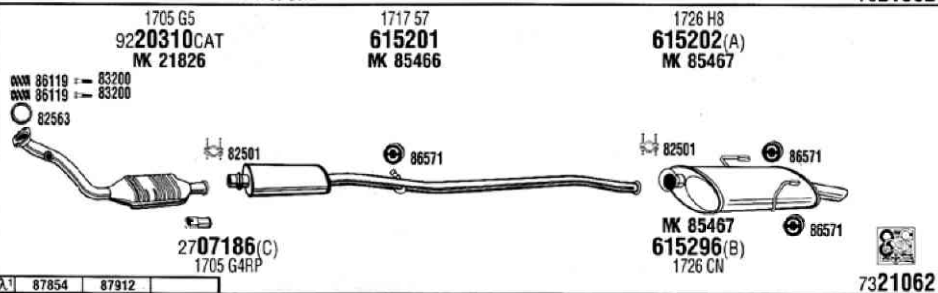

PE40601 **CAT**
406 
 1.8 16v
10/00-03/04
 1749 cc - 117 HP - 86 kW
 Mot/Eng: EW7J4
 (A) -02/03 - (B) 03/03-
 Type/Typ: 8B6FZ

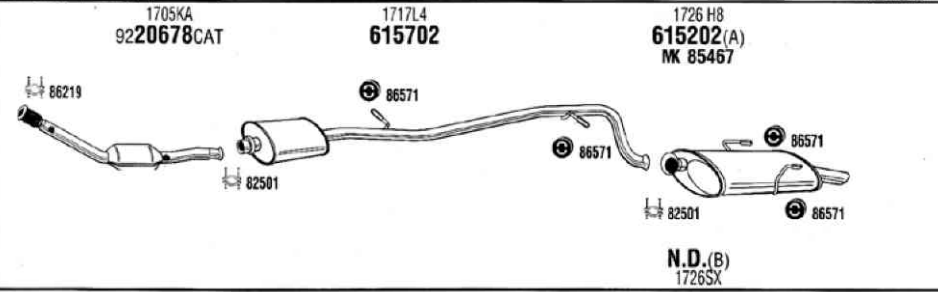

PE40681 **CAT**
406 
 2.0i 16v Autom & Autom AL4
09/95-03/99
 1998 cc - 132 HP - 97 kW
 Mot/Eng: XU10J4R
 Type/Typ: 8BRFVD-8BRFVE-8BRFVW-8BRFV2
 Type/Typ: 8BR6E2-8BR6E4
 λ¹=Eng.RFV

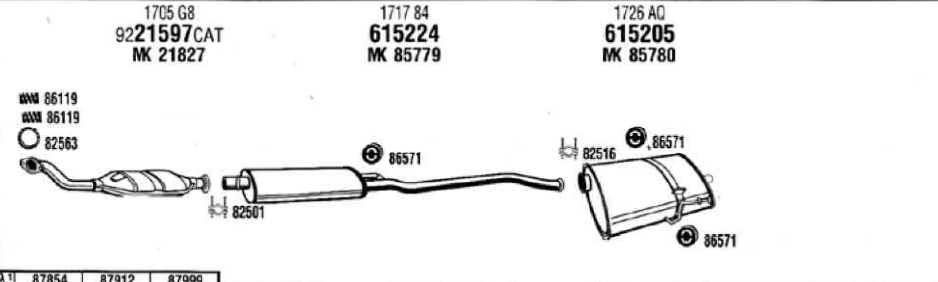

PE40612 **CAT**

● En desarrollo

Los nombres y números de primer equipo se utilizan solamente como referencia

IMPORTANTE:











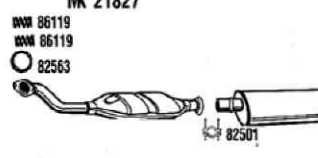

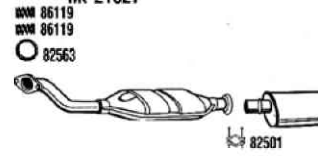
Al pedir sistemas de escape, rogamos completen la referencia comenzando por 'MFO.' (ejemplo: 381394 → MFO.381394)
 Pour commander echappement, nous vous prions de compléter la référence en commençant par MFO..
 When ordering exhaust, please complete the reference by beginning with MFO..

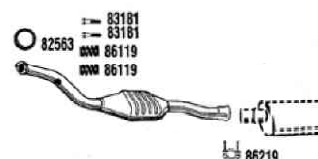
ESCAPE / ECHAPPEMENT / EXHAUST

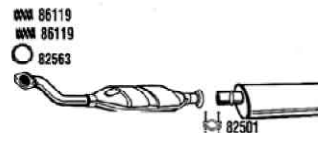
Fonos

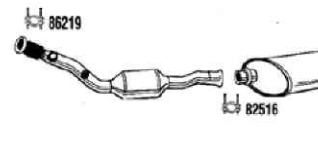
Peugeot

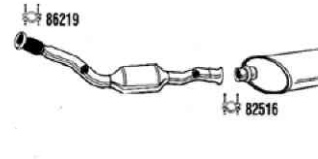
MOTOR / MOTEUR / ENGINE

<p>1705 G8 9221597CAT(A) MK 21827</p>  <p>N.D.CAT(B) 1705-N3</p> <p>A1 87854 87912 87999</p>	<p>1717 84 615224 MK 85779</p>	<p>1726 AQ 615205 MK 85780</p>	<p>406 ST - SV - SRI - GLX - LX  2.0i 16v Autom. & Autom 11/96-03/99 1998 cc - 132 HP - 97 kW Mot/Eng: XU10J4R DEPOL.CEE19-5 (A)= Autom. (B)= Autom Type/Typ: 8BRGE2-8BR6E4-8BRFV2-8BRFV4 TSN: 770 λ¹-Eng.RFV PE40603 CAT</p>
<p>1705 N4 9221598CAT(A) MK 21827</p>  <p>N.D.CAT(B) 1705 N6</p> <p>A1 87854 87912 87999</p>	<p>1717 84 615224 MK 85779</p>	<p>1726 AQ 615205 MK 85780</p>	<p>406 ST - SV - SRI - GLX - LX  2.0i 16v Autom.4HP20 11/96-03/99 1998 cc - 132 HP - 97 kW Mot/Eng: XU10J4R Autom.4HP20 (A)= DEPOL.CEE 95 - (B)= DEPOL.15-04 Type/Typ: 8BRGE2-8BR6E4 - TSN: 770-888 λ¹-Eng.RFV PE40633 CAT</p>
<p>1705P0 ●9220715CAT</p> 	<p>171783 N.D.</p>	<p>1726 P6 615475 MK 85469</p>	<p>406  2.0i Turbo 08/95-04/99 1998 cc - 147 HP - 108 kW Mot/Eng: XU10J2TE Type/Typ: 8BR9X2 PE40634 CAT</p>
<p>1705 G8 9221597CAT(A) MK 21827</p>  <p>A1 87854 87912 87999</p>	<p>1717 84 615224 MK 85779</p>	<p>1726 CX 615297 MK 85780</p>	<p>406  2.0i 16v 04/99-12/99 1998 cc - 132 HP - 97 kW Mot/Eng: XU10J4R (A)= Only for Depol..CEE 95 Type/Typ: 8BR PE40669 CAT</p>
<p>1705 LY 9220352CAT(A)</p> 	<p>1717 L2 615369(B) MK 85779</p>	<p>1726 CX 615297(D) MK 85780</p>	<p>406  2.0 04/99- 1997 cc - 136 HP - 100 kW Mot/Eng: EW10J4 (A) only Euronorm 96 (L3) (B) -05/00 (-0.08575) (C) 05/00- (-0.08576) (D) W/O Chrome - (E) W/ Chrome Finisher Type/Typ: 8BR PE40672 CAT</p>
<p>1705 JY 9220648CAT(A)</p> 	<p>1717 L2 615369(B) MK 85779</p>	<p>1726 CX 615297(D) MK 85780</p>	<p>406  2.0 04/99- 1997 cc - 136 HP - 100 kW Mot/Eng: EW10J4 (A) only Euronorm 2000 (L4) (B) -05/00 (-0.08575) (C) 05/00- (-0.08576) (D) W/O Chrome - (E) W/ Chrome Finisher Type/Typ: 8BR PE40683 CAT</p>

Los nombres y números de primer equipo se utilizan solamente como referencia

● En desarrollo

IMPORTANTE:

Al pedir sistemas de escape, rogamos completen la referencia comenzando por 'MFO.' (ejemplo: 381394 → MFO.381394)

Pour commander echappement, nous vous prions de compléter la référence en commençant par MFO..

When ordering exhaust, please complete the reference by beginning with MFO..

Peugeot

Fonos

406



3.0 24v 6 cyl.
08/95-12/99
2946 cc - 190 HP - 140 kW
Mot/Eng: ES9J4
(A) Depol. CEE 95 Autom.
(B) Depol. CEE 95 Autom.
(C) -04/99 - (D) 04/99-
Type/Typ: 8BXFZ2-8BXFZE-8BXFZP

PE40641 CAT

1705 X1 1705 R1 1709 14
N.D. N.D. N.D.

1731 76
N.D.CAT(A)

1717 85
615226
MK 85510

1726 P6
615475(C)
MK 85469

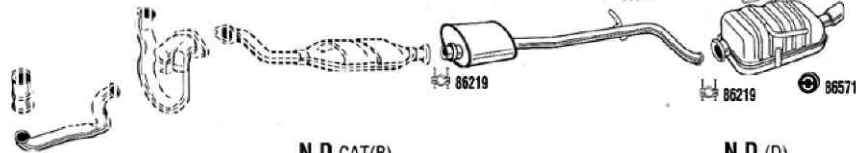

N.D.CAT(B)
1731 H8

N.D.(D)
1726 EF

406



3.0 24v
04/99-
2946 cc - 207 HP - 152 kW
Mot/Eng: ES9J4S
(A) -05/00 (= 0.08575) (B) 05/00- (= 0.08575)
Type/Typ: 8BXFXF-8BXFXR-8BXFXF-8BXFXR

PE40644 CAT

1705 GA
N.D.

1705 KX
N.D.

1731 K1
N.D.CAT

1717 85
615226(A)
MK 85510

1726 EF
N.D.

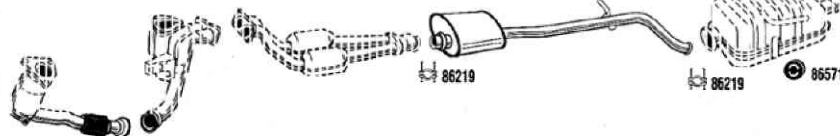

615705(B)
1717 J2

406

SL - ST - SV - LX - GLX

1.9 TD
08/95-10/97
1905 cc - 90 HP - 66 kW
Mot/Eng: XUD9TE
Type/Typ: 8BD9B2-8BDIX2

PE40604

1705-CF
615206
MK 85468

1726-AL
615207
MK 85469



406

SLdt-SRdt-STdt
SVdt-GLXdt-LXdt

1.9 TD
08/95-10/97
1905 cc - 94 HP - 69 kW
Mot/Eng: XUD9TE
Type/Typ: 8BD9B2
TSN: 772

PE40613

1705-CF
615206
MK 85468

1726-AL
615207
MK 85469



406

SLdt-SRdt-STdt
SVdt-GLXdt-LXdt

1.9 TD
08/95-04/99
1905 cc - 90 HP - 66 kW
Mot/Eng: XUD9TE
(A) Repair pipe int.diam.60,5 mm
(B) Repair pipe int.diam.54,5 mm
Type/Typ: 8BDHX2-8BD8D2-8BDHXE - TSN: 772

PE40614 CAT

1705 CJ
9821743CAT
MK 21829

1726-AL
615207
MK 85469

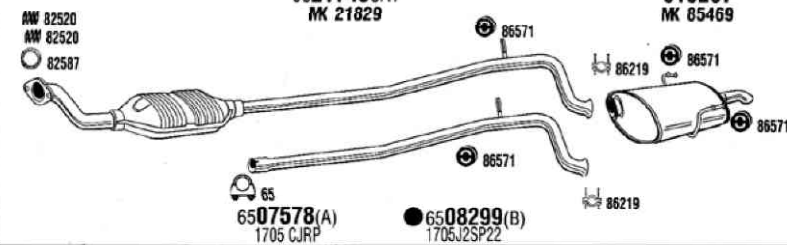

6507578(A)
1705 CJRP

6508299(B)
1705J2SP22

406

1.9 SD TD
06/96-04/99
1905 cc - 75 HP - 55 kW
Mot/Eng: XUD9SD
(A) repair pipe
Type/Typ: 8BDHWE

PE40637 CAT

1705 R5
9820588CAT

1726 N3
615221
MK 85467

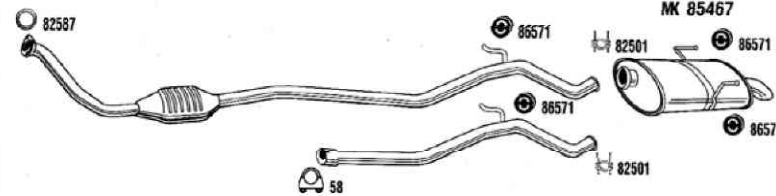

6507583(A)
1705 R5(RP)

● En desarrollo

Los nombres y números de primer equipo se utilizan solamente como referencia

IMPORTANTE:

Al pedir sistemas de escape, rogamos completen la referencia comenzando por 'MFO.' (ejemplo: 381394 → MFO.381394)
Pour commander echappement, nous vous prions de compléter la référence en commençant par MFO..
When ordering exhaust, please complete the reference by beginning with MFO..

Fonos

ESCAPE / ECHAPPEMENT / EXHAUST

<p>1705 R5 9820588CAT</p> <p>1726 N3 615221 MK 85467</p> <p>6507583(A) 1705 R5(RP)</p>	<p>406</p> <p>1.9 Diesel 05/98-03/99 1868 cc - 75 HP - 55 kW Mot/Eng: XUD9BSD (DHV) (A) repair pipe Type/Typ: 8BDHVF</p> <p>PE40639 CAT</p>
<p>1705 CJ 9821743CAT MK 21829</p> <p>1726 AL 615207 MK 85469</p> <p>6507578(A) 1705 CJ(RP)</p> <p>6508299(B) 1705J2SP22</p> <p>7321099</p>	<p>406</p> <p>SL - ST - SV - LX - GLX 1.9 TD 10/95- 1905 cc - 90 HP - 66 kW Mot/Eng: XUD9TE (A) Repair pipe int.diam.60.5 mm (B) Repair pipe int.diam.54.5 mm Type/Typ: 8BD8B2-8BDHX2-8BD8BD</p> <p>PE40605 CAT</p>
<p>1705 EG 9820353CAT(A)</p> <p>1705 HK N.D.CAT(B)</p> <p>1726 AA 615432 MK 85780</p> <p>6507583(C) 1705 R5(RP)</p>	<p>406</p> <p>2.0 HDi 06/98- 1997 cc - 90 HP - 66 kW Mot/Eng: DW10TD DEPOL CEE95 (A)-05/00 (=0.08575) - (B) 05/00- (=0.08576) (C) repair pipe Type/Typ: 8BR</p> <p>PE40652 CAT</p>
<p>1705 EG 9820353CAT(B)</p> <p>1726 AA 615432 MK 85780</p> <p>9820353CAT(A) 1705 EG</p>	<p>406</p> <p>2.0 HDi 06/98- 1997 cc - 90 HP - 66 kW Mot/Eng: DW10TD (A) -05/00 (=0.08575) (B) 05/00- (=0.08576) DEPOL CEE 2000 Type/Typ: 8BR</p> <p>PE40653 CAT</p>
<p>1705 FC 9220548CAT</p> <p>1717 C7 615368(A)</p> <p>1726 AA 615432 MK 85780</p> <p>615794(B) 1717 J1</p>	<p>406</p> <p>2.0 HDi 06/98- 1997 cc - 109 HP - 80 kW Mot/Eng: DW10ATED (A) -05/00 (=0.08575) - (B) 05/00- (=0.08576) W/O PARTICLE FILTER Type/Typ: 8BR-8BR</p> <p>PE40650 CAT</p>
<p>1705 LS N.D.</p> <p>N.D.CAT</p> <p>N.D.CAT(A)</p> <p>1717 L6 6707196</p> <p>1726 JG 615559</p> <p>PE40675 CAT</p>	<p>406</p> <p>2.0 HDi 04/99- 1997 cc - 109 HP - 80 kW Mot/Eng: DW10ATED W/ PARTICLE FILTER (A)= particle filter Type/Typ: 8BR-8BR</p> <p>PE40675 CAT</p>

Los nombres y números de primer equipo se utilizan solamente como referencia

● En desarrollo

IMPORTANTE:

Al pedir sistemas de escape, rogamos completen la referencia comenzando por 'MFO.' (ejemplo: 381394 → MFO.381394)

Pour commander echappement, nous vous prions de compléter la référence en commençant par MFO..

When ordering exhaust, please complete the reference by beginning with MFO..

Peugeot

Fonos

406

 2.1 TD
08/95-10/97
 2088 cc - 109 HP - 80 kW
 Mot/Eng: XUD11BTE
 Type/Typ: 8BP8C2-8CP8C2

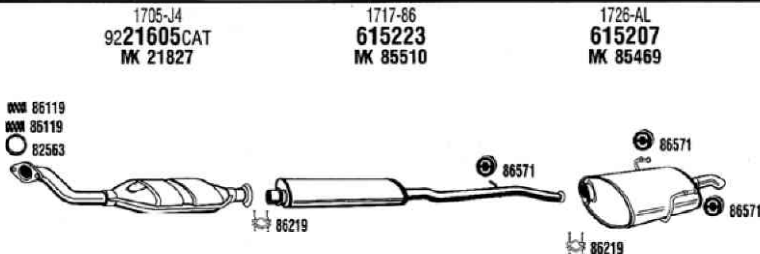
PE40615 **CAT**

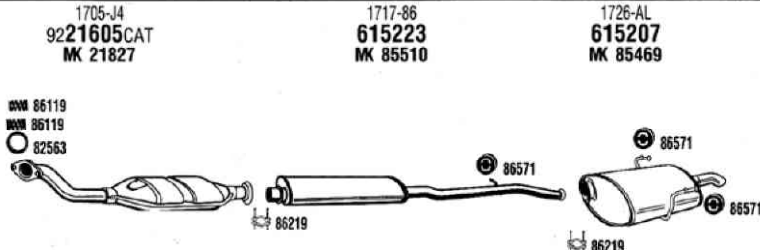

406
SV

 2.1 TD
10/95-
 2088 cc - 109 HP - 80 kW
 Mot/Eng: XUD11BTE
 Type/Typ: 8BP8C2
 TSN: 773

PE40607 **CAT**

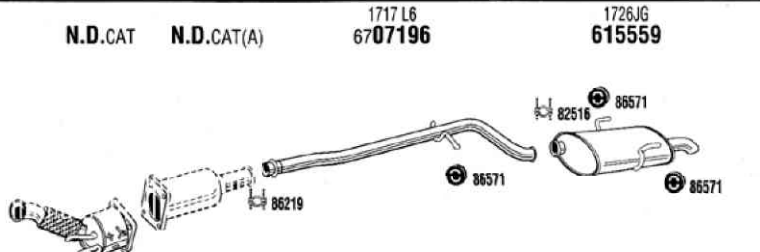

406

 2.2 HDi
09/00-
 2179 cc - 133 HP - 98 kW
 Mot/Eng: DW12TED4
 W/ PARTICLE FILTER
 (A)= particle filter
 Type/Typ: 8BR-8B4

PE40677 **CAT**

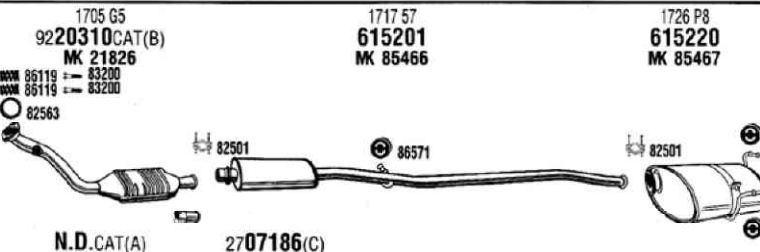

406
SL-SR-ST 
 1.6i
03/97-
 Mot/Eng: XU5JP
 (A)= US83 CEE 19.5 (B)= CEE 95 L3
 (C) Repair pipe Cat 20310

PE40617 **CAT**



406

 1.8i
10/96-08/00
 1781 cc - 101 HP - 74 kW
 Mot/Eng: XU7JP
 Type/Typ: 8EL6A2-8ELFXE-8FLFXE

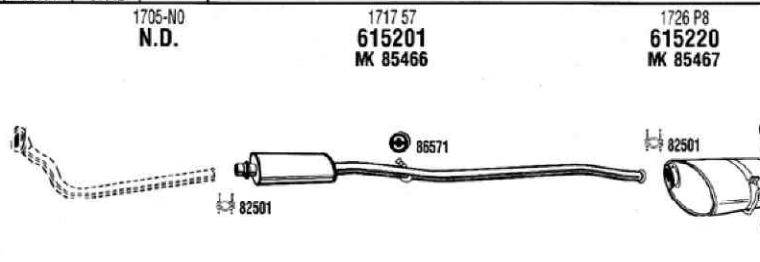
PE40619

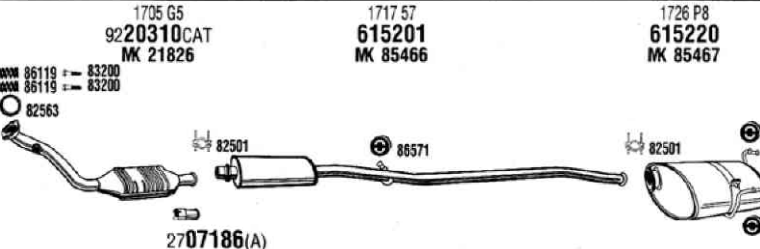

406
SL-SR-ST 
 1.8i
10/96-12/99
 1766 cc - 90 HP - 66 kW
 Mot/Eng: XU7JB
 (A) Repair pipe Cat 20310
 Type/Typ: 8ELFXE-8FLFXE - TSN: 857
 λ¹=10/96->12/96

PE40618 **CAT**



● En desarrollo

Los nombres y números de primer equipo se utilizan solamente como referencia

IMPORTANTE:

Al pedir sistemas de escape, rogamos completen la referencia comenzando por 'MFO.' (ejemplo: 381394 → MFO.381394)
 Pour commander echappement, nous vous prions de compléter la référence en commençant par MFO..
 When ordering exhaust, please complete the reference by beginning with MFO..

ESCAPE / ECHAPPEMENT / EXHAUST

Fonos

Peugeot

1705 G5 9220310CAT(B) MK 21826	1717 57 615201 MK 85466	1726 P8 615220 MK 85467
--------------------------------------	-------------------------------	-------------------------------

2707187(A)
1705 G5RP

7321062

406
GLX-LX-SL-SR-ST-SV
1.8i 16v
10/96-08/00
1761 cc - 111 HP - 82 kW
Mot/Eng: XU7JP4
(A) Repair pipe Cat 20310
(B) Except Depol. D3 and Depol. CEE 2000
Type/Typ: 8ELF*-8FLF* - TSN: 801
λ¹=Exc. Depol. CEE 2000

PE40620 **CAT**

1705 G5 9220310CAT(A) MK 21826	1717 57 615201 MK 85466	1726 P8 615220 MK 85467
--------------------------------------	-------------------------------	-------------------------------

2707187(B)
1705 G5RP

7321062

406

1.8i 16v (LPG)
10/97-08/00
1761 cc - 110 HP - 81 kW
Mot/Eng: XU7JP4GPL
(A) Depol. US-83 / 19-5 / CEE 95
(B) Repair pipe Cat 20310
Type/Typ: 8BLF,8ELF - TSN: 801

PE40632 **CAT**

1705KA 9220678CAT	1717L4 615702	1726HZ 615703(A)
----------------------	------------------	---------------------

N.D.(B)
1726SY

406

1.8 16v
10/00-04/04
1749 cc - 117 HP - 86 kW
Mot/Eng: EW7J4
(A) -02/03 - (B) 03/03-
Type/Typ: 8EGFZ,8FGFZ

PE40682 **CAT**

1705 G8 9221597CAT(A) MK 21827	1717 84 615224 MK 85779	1726-AR 615603 MK 85780
--------------------------------------	-------------------------------	-------------------------------

N.D.CAT(B)
1705-N3

406
ST-SV-LX-GLX-SRi
2.0i 16v Autom. & Autom.
11/96-03/99
1998 cc - 132 HP - 97 kW
Mot/Eng: XU10J4R
DEPOL. CEE 19-5
(A)= Autom. - (B)= Autom.
Type/Typ: 8ER6E2-8ER6E4-8FR6E2-8FR6E4
λ¹=Eng. RFV

PE40624 **CAT**

1705 G8 9221597CAT MK 21827	1717 84 615224 MK 85779	1726-AR 615603 MK 85780
-----------------------------------	-------------------------------	-------------------------------

406
ST-SV-LX-GLX-SRi
2.0i 16v
03/97-
Mot/Eng: XU10J4R
Autom. 4HP20
λ¹=Eng. RFV

PE40625 **CAT**

1705 G8 9221597CAT MK 21827	1717 84 615224 MK 85779	1726-AR 615603 MK 85780
-----------------------------------	-------------------------------	-------------------------------

406
ST-SV-LX-GLX-SRi
2.0i 16v Autom. & Autom. AL4
11/96-03/99
1998 cc - 132 HP - 97 kW
Mot/Eng: XU10J4R
TSN: 806
λ¹=Eng. RFV

PE40621 **CAT**

Los nombres y números de primer equipo se utilizan solamente como referencia

● En desarrollo

IMPORTANTE:

Al pedir sistemas de escape, rogamos completen la referencia comenzando por 'MFO.' (ejemplo: 381394 → MFO.381394)
 Pour commander echappement, nous vous prions de compléter la référence en commençant par MFO..
 When ordering exhaust, please complete the reference by beginning with MFO..

MOTOR / MOTEUR / ENGINE

406
ST-SV-LX-GLX-SRI 
 2.0i 16v Autom.4HP20
11/96-03/99
 1998 cc - 132 HP - 97 kW
 Mot/Eng: XU10J4R
 Autom. 4HP20
 (A)= DEPOL.CEE 95 - (B)= DEPOL. 15-04
 TSN: 806
 λ¹-Eng.RFV

PE40622 **CAT**

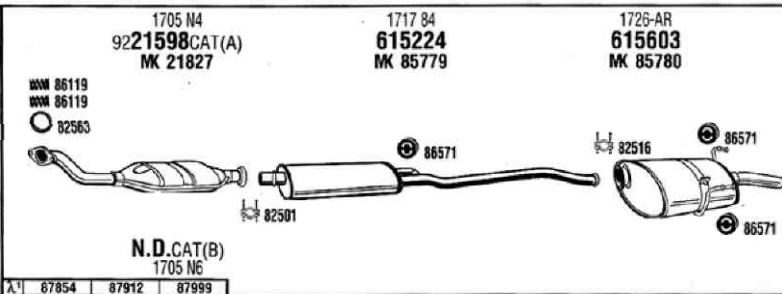

406 
 2.0i 16v
04/99-
 1998 cc - 132 HP - 97 kW
 Mot/Eng: XU10J4R
 Type/Typ: 8BR
 λ¹-Eng. RFV

PE40670 **CAT**

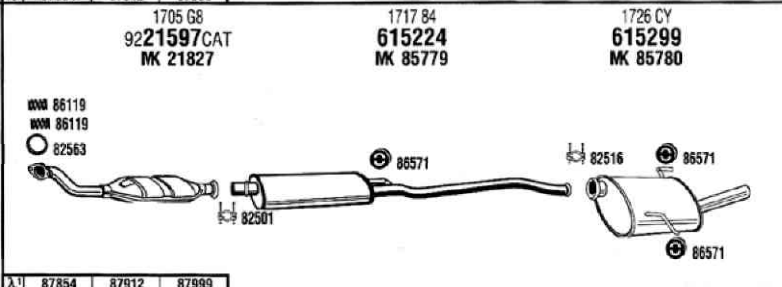

406 
 2.0
04/99-
 1997 cc - 136 HP - 100 kW
 Mot/Eng: EW10J4
 (A) only Euronorm 96 (L3)
 (B) -05/00 (=0.08575) (C) 05/00- (=0.08576)
 Type/Typ: 8ER-8FR

PE40673 **CAT**

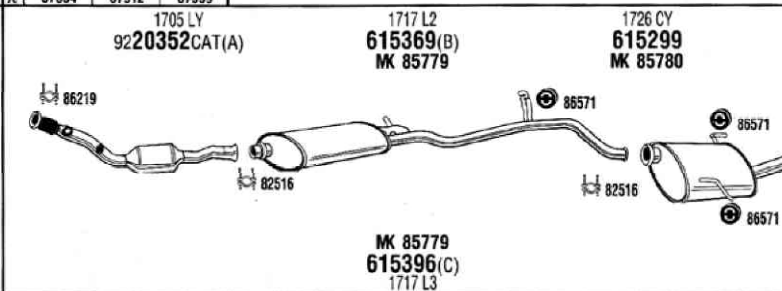

406 
 2.0
04/99-
 1997 cc - 136 HP - 100 kW
 Mot/Eng: EW10J4
 (A) only Euronorm 2000 (L4)
 (B) -05/00 (=0.08575) (C) 05/00- (=0.08576)
 Type/Typ: 8ER-8FR

PE40684 **CAT**

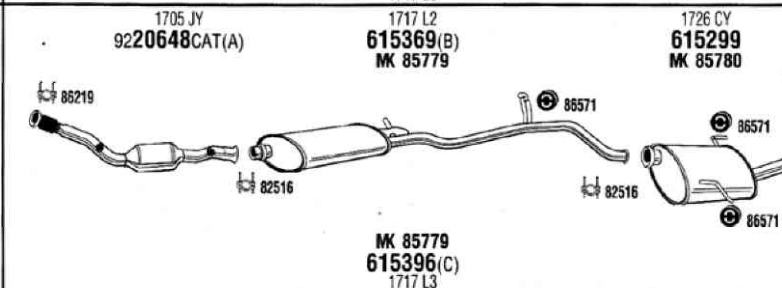

406 
 3.0 24v 6 cyl.
11/96-12/99
 2946 cc - 190 HP - 140 kW
 Mot/Eng: ES9J4
 Type/Typ: 8EXFZ2-8EXFZE8EXFZP
 λ¹-Depol.EUR095/EUR095

PE40640 **CAT**

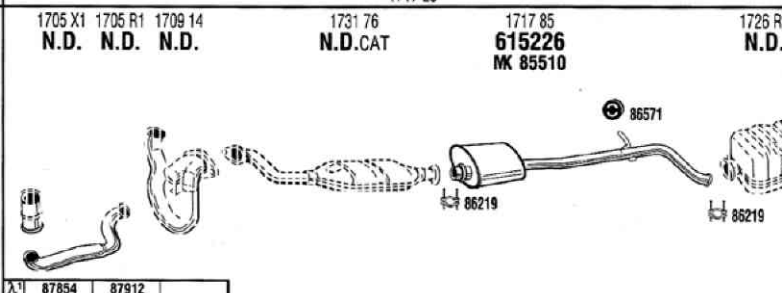

406 
 3.0 24v
04/99-
 2946 cc - 207 HP - 152 kW
 Mot/Eng: ES9J4S
 (A) -05/00 (= 0.08575) (B) 05/00- (= 0.08575)
 Type/Typ: 8EXFXF-8EXFXH

PE40643 **CAT**

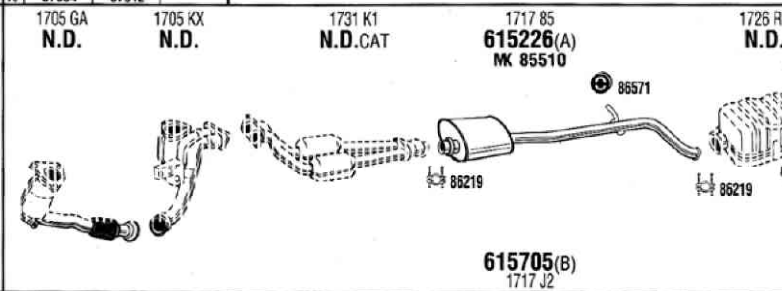

850 ● En desarrollo

Los nombres y números de primer equipo se utilizan solamente como referencia

IMPORTANTE:

Al pedir sistemas de escape, rogamos completen la referencia comenzando por 'MFO.' (ejemplo: 381394 → MFO.381394)
 Pour commander echappement, nous vous prions de compléter la référence en commençant par MFO..
 When ordering exhaust, please complete the reference by beginning with MFO..

ESCAPE / ECHAPPEMENT / EXHAUST

Fonos

Peugeot

MOTOR / MOTEUR / ENGINE

<p>1705-CF 615206 MK 85468</p> <p>1726 AN 615608 MK 85469</p>	<p>406 SLdt-SRdt-STdt SVdt-GLXdt-LXdt 1.9 TD 03/97-10/97 1905 cc - 90 HP - 66 kW Mot/Eng: XUD9TE</p> <p>PE40626</p>
<p>1705 CJ 9821743CAT MK 21829</p> <p>1726 AN 615608 MK 85469</p> <p>65 07578(A) 1705 CJRP</p> <p>● 6508299(B) 1705J2SP22</p>	<p>406 SLdt-SRdt-STdt SVdt-GLXdt-LXdt 1.9 TD 03/97-04/99 1905 cc - 90 HP - 66 kW Mot/Eng: XUD9TE (A) Repair pipe int.ciam.60,5 mm (B) Repair pipe int.ciam.54,5 mm Type/Typ: 8EDHX2-8ED8D2-8FDHX2 - TSN: 802</p> <p>PE40627 CAT</p>
<p>1705 R5 9820588CAT</p> <p>1726 R2 615222 MK 85467</p> <p>65 07583(A) 1705 R5(RP)</p>	<p>406 1.9 SD TD 10/96-04/99 1905 cc - 75 HP - 55 kW Mot/Eng: XUD9SD (A) repair pipe Type/Typ: 8BDHWE, 8EDHWE, 8FDHWE</p> <p>PE40638 CAT</p>
<p>1705 EG 1705 HK 9820353CAT(A) N.D.CAT(B)</p> <p>1726 Z9 615828 MK 85780</p> <p>65 07583(C) 1705 R5(RP)</p>	<p>406 2.0 HDi 06/98- 1997 cc - 90 HP - 66 kW Mot/Eng: DW10TD DEPOL.CEE 95 (A) -05/00 (=0.08575) - (B) 05/00- (=0.08576) (C) repair pipe Type/Typ: 8FR</p> <p>PE40654 CAT</p>
<p>1705 EG 9820353CAT(B)</p> <p>1726 Z9 615828 MK 85780</p> <p>9820353CAT(A) 1705 EG</p>	<p>406 2.0 HDi 06/98- 1997 cc - 90 HP - 66 kW Mot/Eng: DW10TD DEPOL.CEE 2000 (A) -05/00 (=0.08575) - (B) 05/00- (=0.08576) Type/Typ: 8BR</p> <p>PE40655 CAT</p>
<p>1705 FC 9220548CAT</p> <p>1717 C7 615368(A)</p> <p>1726 Z9 615828 MK 85780</p> <p>615794(B) 1717 J1</p>	<p>406 2.0 HDi 06/98- 1997 cc - 109 HP - 80 kW Mot/Eng: DW10ATED (A) -05/00 (=0.08575) - (B) 05/00- (=0.08576) W/O PARTICLE FILTER Type/Typ: 8ERHZE</p> <p>PE40651 CAT</p>

Los nombres y números de primer equipo se utilizan solamente como referencia

● En desarrollo

IMPORTANTE:

Al pedir sistemas de escape, rogamos completen la referencia comenzando por 'MFO.' (ejemplo: 381394 → MFO.381394)

Pour commander echappement, nous vous prions de compléter la référence en commençant par MFO..

When ordering exhaust, please complete the reference by beginning with MFO..

Peugeot

Fonos

406

2.0 HDi
04/99-
1997 cc - 109 HP - 80 kW
Mot/Eng: DW10ATED
W/ PARTICLE FILTER
(A)= particle filter
Type/Typ: 8ER-8FR

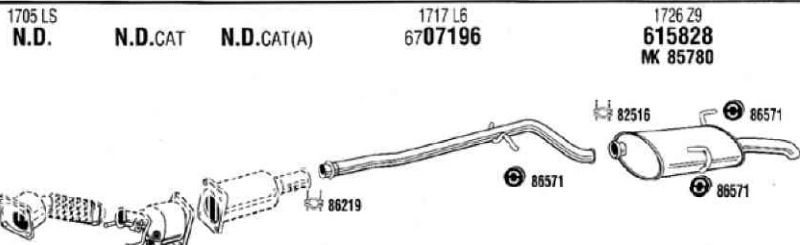

PE40676 CAT

406

SVdt-GLXdt-LXdt-STdt
2.1 TD
09/95-10/97
2088 cc - 109 HP - 80 kW
Mot/Eng: XUD11BTE
Type/Typ: 8BP8CD-8BP8CE-8BP8C2-8EP8C2

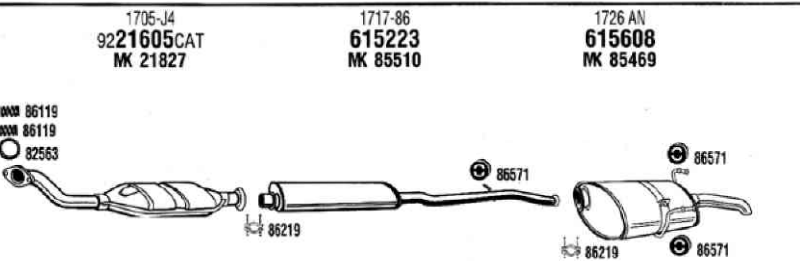

PE40616 CAT

406

STdt-SVdt-LXdt-GLXdt
2.1 TD
11/96-03/99
2088 cc - 109 HP - 80 kW
Mot/Eng: XUD11BTE
Type/Typ: 8EP8CE-8FP8CE
TSN: 804

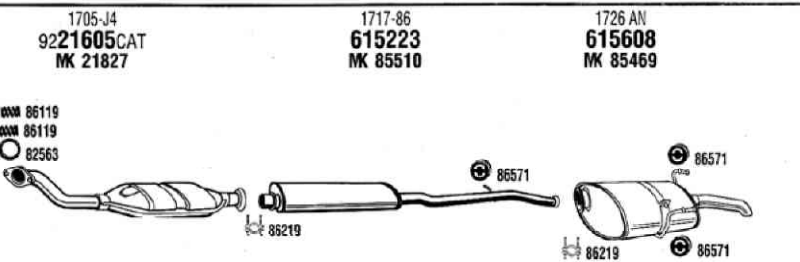

PE40629 CAT

406

2.2 HDi
09/00-
2179 cc - 133 HP - 98 kW
Mot/Eng: DW12TED4
W/ PARTICLE FILTER
(A)= particle filter
Type/Typ: 8E4-8ER-8F4

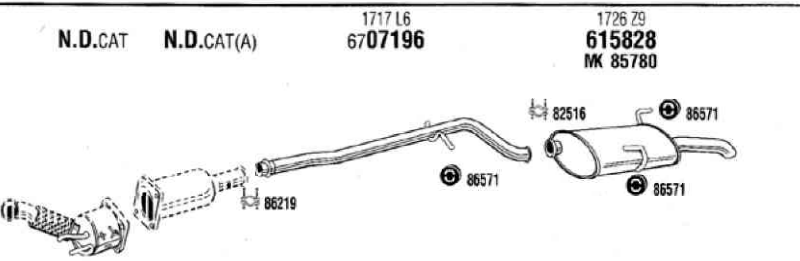

PE40678 CAT

406

Coupé
2.0i 16v
03/97-12/99
1998 cc - 132 HP - 97 kW
Mot/Eng: XU10J4R
Except Depol. 15-04 - (A) Except see (B) and (C)
(B) CEE 95 L3 Autom. 03/97-05/99
(C) CEE 19-5 Autom. - (D)= -05/99 (E)= 05/99-
Type/Typ: 8CRF - TSN: 819

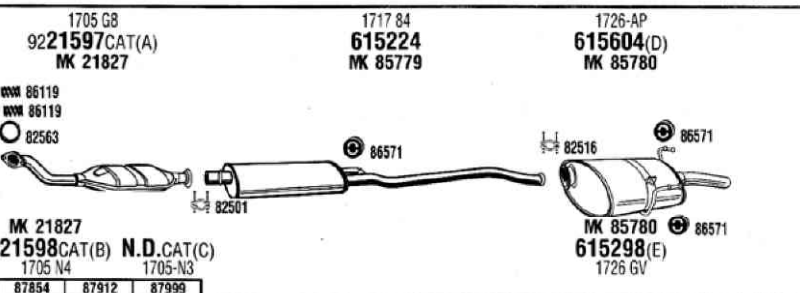

PE40630 CAT

406

Coupé
2.0
04/99-
1997 cc - 136 HP - 100 kW
Mot/Eng: EW10J4
(A) only Euro norm 96 (L3)
(B) -05/00 (-0.08575) (C) 05/00- (-0.08576)
Type/Typ: 8CRF*

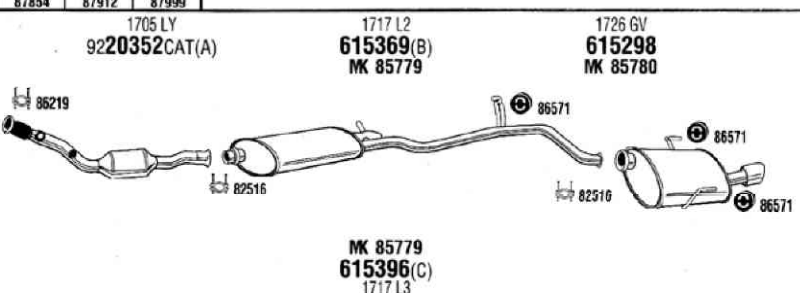

PE40674 CAT

● En desarrollo

Los nombres y números de primer equipo se utilizan solamente como referencia

IMPORTANTE:

Al pedir sistemas de escape, rogamos completen la referencia comenzando por 'MFO.' (ejemplo: 381394 → MFO.381394)
Pour commander echappement, nous vous prions de compléter la référence en commençant par MFO..
When ordering exhaust, please complete the reference by beginning with MFO..

ESCAPE / ECHAPPEMENT / EXHAUST

Fonos

1705 JY 92 20648 CAT(A)	1717 L2 615369 (B) MK 85779	1726 GV 615298 MK 85780
-----------------------------------	--	--------------------------------------

1705 X1 1705 R1 1709 14
N.D. N.D. N.D.

1731 76
N.D.CAT(A)

1717 85
615226
MK 85510

1726 P6
615475
MK 85469

615396(C)
1717 L3

1705 GA
N.D.

1705 KX
N.D.

1731 K1
N.D.CAT

1717 85
615226(A)
MK 85510

1726 N2
N.D.

615705(B)
1717 J2

406 Coupé
2.0
04/99-
1997 cc - 136 HP - 100 kW
Mot/Eng: EW10J4
(A) only Euronorm 2000 (L4)
(B) -05/00 (=0.08575) (C) 05/00- (=0.08575)
Type/Typ: 8CRF*

PE40685 **CAT**

1705 X1 1705 R1 1709 14 N.D. N.D. N.D.	1731 76 N.D.CAT(A)	1717 85 615226 MK 85510	1726 P6 615475 MK 85469
---	-----------------------	--------------------------------------	--------------------------------------

615396(C)
1717 L3

1705 GA
N.D.

1705 KX
N.D.

1731 K1
N.D.CAT

1717 85
615226(A)
MK 85510

1726 N2
N.D.

615705(B)
1717 J2

406 Coupé
3.0 24v 6 cyl.
05/97-12/99
2946 cc - 190 HP - 140 kW
Mot/Eng: ES9J4
(A) Depot. CEE 95 Autom.
(B) Depot. CEE 95 Autom.
Type/Typ: 8CXF**

PE40642 **CAT**

1705 GA N.D.	1705 KX N.D.	1731 K1 N.D.CAT	1717 85 615226 (A) MK 85510	1726 N2 N.D.
-----------------	-----------------	--------------------	--	-----------------

615396(C)
1717 L3

1705 GA
N.D.

1705 KX
N.D.

1731 K1
N.D.CAT

1717 85
615226(A)
MK 85510

1726 N2
N.D.

615705(B)
1717 J2

406 Coupé
3.0 24v
05/99-
2946 cc - 207 HP - 152 kW
Mot/Eng: ES9J4S
(A) 05/00 (= 0.08575) (B) 05/00- (= 0.08575)
Type/Typ: 8CXFXF-8CXFXR

PE40645 **CAT**

N.D.CAT	N.D.CAT(A)	1717 L6 67 07196	1726 JR N.D.
---------	------------	----------------------------	-----------------

1705 GA
N.D.

1705 KX
N.D.

1731 K1
N.D.CAT

1717 85
615226(A)
MK 85510

1726 N2
N.D.

615705(B)
1717 J2

406 Coupé
2.2 HDi
09/00-
2179 cc - 133 HP - 98 kW
Mot/Eng: DW12TED4
W/ PARTICLE FILTER
(A)= particle filter
Type/Typ: 8C

PE40679 **CAT**

1720-03 51 01287	1702-03 66 01322	1722-18 51 01323	1724-68 65 01324 MK 85163
----------------------------	----------------------------	----------------------------	--

1705 GA
N.D.

1705 KX
N.D.

1731 K1
N.D.CAT

1717 85
615226(A)
MK 85510

1726 N2
N.D.

615705(B)
1717 J2

504 L
1.8
03/73-06/79
1796 cc - 73 HP - 54 kW
Mot/Eng: XM7
ch.no. -2791702
Type/Typ: 504M01
TSN: 409

PE50409

1702-72 62 01326	1792-19 N.D.	1722-18 51 01323	1724-68 65 01324 MK 85163
----------------------------	-----------------	----------------------------	--

1705 GA
N.D.

1705 KX
N.D.

1731 K1
N.D.CAT

1717 85
615226(A)
MK 85510

1726 N2
N.D.

615705(B)
1717 J2

504 L
1.8 Autom.
03/73-06/79
1796 cc - 73 HP - 54 kW
Mot/Eng: XM7
ch.no. -2791702
Type/Typ: 504M03
TSN: 409

PE50410

Los nombres y números de primer equipo se utilizan solamente como referencia

● En desarrollo

IMPORTANTE:

Al pedir sistemas de escape, rogamos completen la referencia comenzando por 'MFO.' (ejemplo: 381394 → MFO.381394)
 Pour commander echappement, nous vous prions de compléter la référence en commençant par MFO..
 When ordering exhaust, please complete the reference by beginning with MFO..

504
L-GR-SR 
 1.8
07/79-06/82
 1796 cc - 79 HP - 58 kW
 Mot/Eng: XM7P
 ch.no. 2791703-3791402
 Type/Typ: 504M01-504M51
 TSN: 376-433

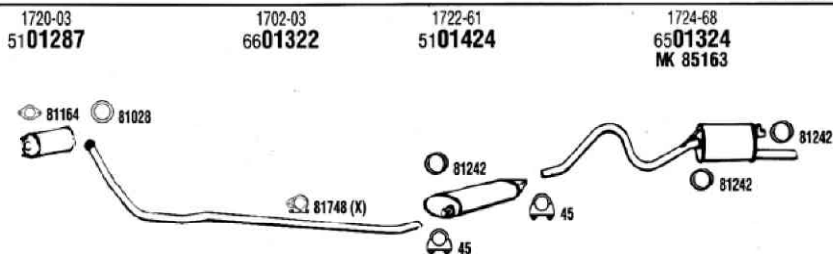

PE50411
504
L-GR-SR 
 1.8 Autom.
07/79-06/82
 1796 cc - 79 HP - 58 kW
 Mot/Eng: XM7P
 ch.no. 2791703-3791402
 Type/Typ: 504M03-504M53
 TSN: 376-433

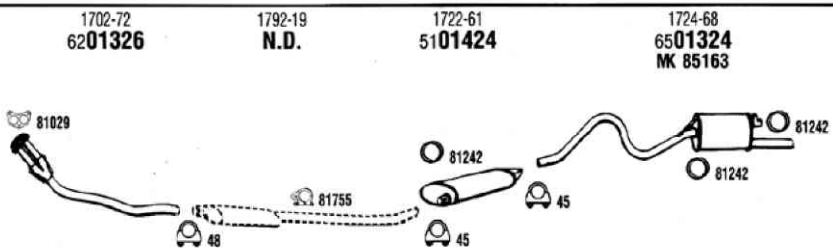

PE50413
504
L-GR-SR 
 1.8
07/82-12/83
 1796 cc - 79 HP - 58 kW
 Mot/Eng: XM7P
 ch.no. 3791403-
 Type/Typ: 504M51
 TSN: 376-433

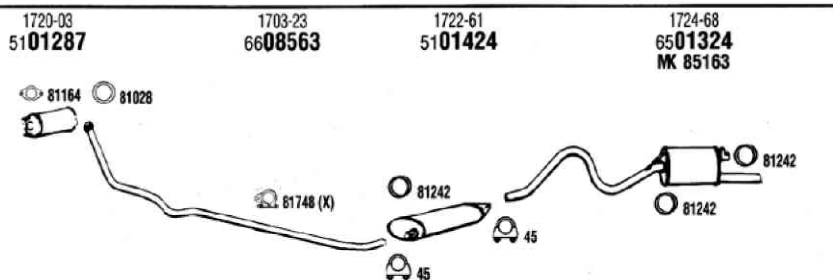

PE50412
504
L-GR-SR 
 1.8 Autom.
07/82-12/83
 1796 cc - 79 HP - 58 kW
 Mot/Eng: XM7P
 ch.no. 3791403-
 Type/Typ: 551M53
 TSN: 376-433

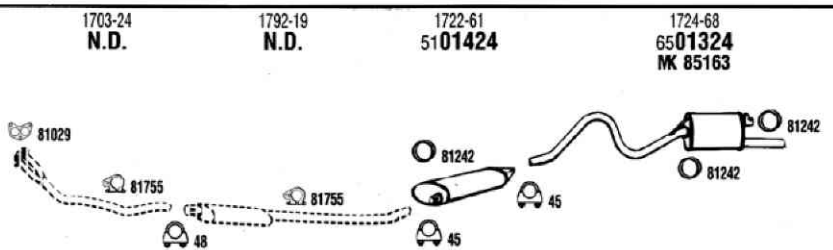

PE50414
504

 1.8
01/68-12/72
 1796 cc - 73 HP - 54 kW
 Mot/Eng: XM7
 ch.no. -1572183
 Type/Typ: 504D11-504D20
 TSN: 364-374

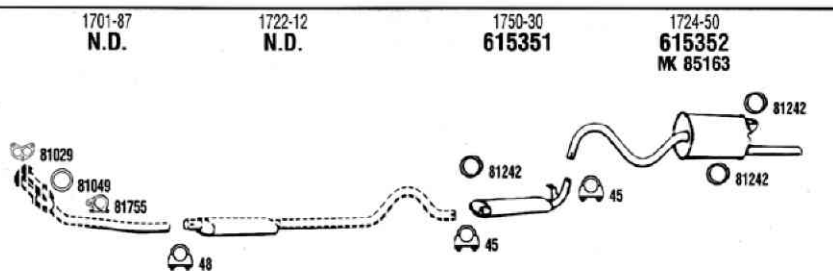

7301353

PE50469
504

 1.8
01/73-06/82
 1796 cc - 73 HP - 54 kW
 Mot/Eng: XM7
 ch.no. 1512184-3791707
 Type/Typ: 504D11-504F11-504F40
 TSN: 364-391

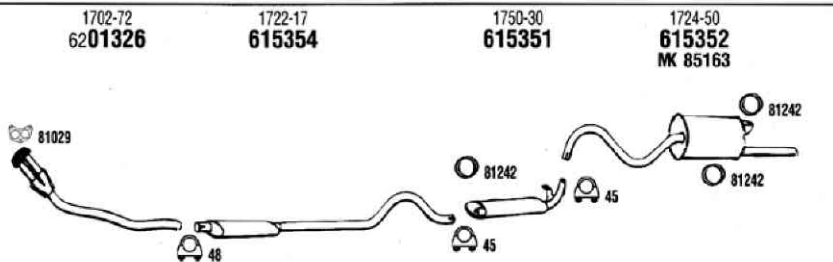

7301353

● En desarrollo

Los nombres y números de primer equipo se utilizan solamente como referencia

IMPORTANTE:







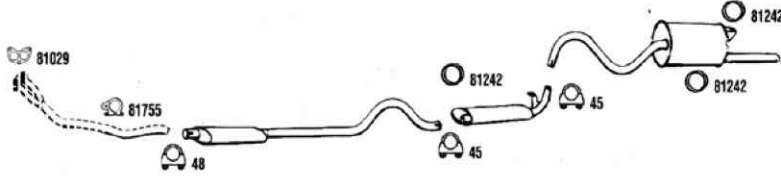

Al pedir sistemas de escape, rogamos completen la referencia comenzando por 'MFO.' (ejemplo: 381394 → MFO.381394)
 Pour commander echappement, nous vous prions de compléter la référence en commençant par MFO..
 When ordering exhaust, please complete the reference by beginning with MFO..

ESCAPE / ECHAPPEMENT / EXHAUST

Fonos

Peugeot

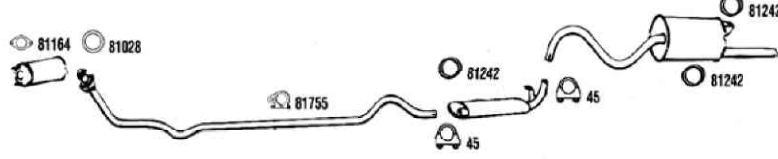
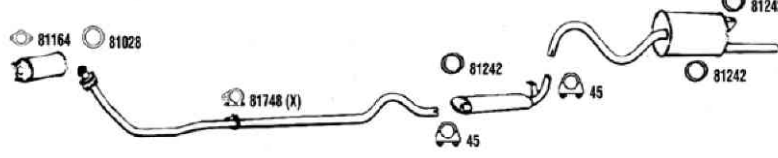
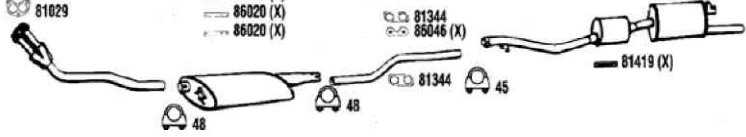
MOTOR / MOTEUR / ENGINE

1703-24 N.D.	1722-17 615354	1750-30 615351	1724-50 615352 MK 85163		504  1.8 07/82-12/83 1796 cc - 73 HP - 54 kW Mot/Eng: XM7 ch.no. 3791708- Type/Typ: 504E01-504D11-504F11 TSN: 364-374
1720-03 5101287	1702-56 N.D.	1702-57 N.D.	1725-48 615417		504 Pick up-  1.8 10/79-07/82 1796 cc - 79 HP - 58 kW Mot/Eng: XM7P ch.no. -3759909 Type/Typ: 504U01-504V01-504V51
1721-25 N.D.	1703-15 6208564	1728-11 6608566	1725-48 615417		504 Pick up-  1.8 07/82-10/93 1796 cc - 73 HP - 54 kW Mot/Eng: XM7 ch.no. 3759910- Type/Typ: 504V01-504V51
1720-03 5101287	1703-22 6708561	1750-30 615351	1724-50 615352 MK 85163		504 Commerciale 1.8 07/82-12/83 1796 cc - 73 HP - 54 kW Mot/Eng: XM7 ch.no. 3791708- Type/Typ: 504E01 TSN: 409
1720-03 5101287	1720-04 6601357	1750-30 615351	1724-50 615352 MK 85163		504 Commerciale 1.8 08/75-06/82 1796 cc - 73 HP - 54 kW Mot/Eng: XM7 ch.no. -3791707 Type/Typ: 504E01 TSN: 409
1702-68 1501(A)	1721-34 631502	1722-15 31503	1725-54 631504		504 GL-Ti  2.0, 2.0i 07/72-12/80 1971 cc - 93, 104 HP - 68, 76 kW Mot/Eng: XN1-XN2 (A) L.H.D (B) R.H.D (C)  Type/Typ: 504A11-504A12-504A13-504A14 TSN: 348-350-351

Los nombres y números de primer equipo se utilizan solamente como referencia

● En desarrollo

IMPORTANTE:

Al pedir sistemas de escape, rogamos completen la referencia comenzando por 'MFO.' (ejemplo: 381394 → MFO.381394)

Pour commander echappement, nous vous prions de compléter la référence en commençant par MFO..

When ordering exhaust, please complete the reference by beginning with MFO..

Peugeot

Fonos

MOTOR / MOTEUR / ENGINE

504
Coupé-Cabrio
 2.0i
10/77-12/83
 1971 cc - 104 HP - 76 kW
 Mot/Eng: XN2
 (A) -06/79 (B) 07/79-
 (C) ©
 Type/Typ: 504B12-504B14-504C12-504C14
 TSN: 902

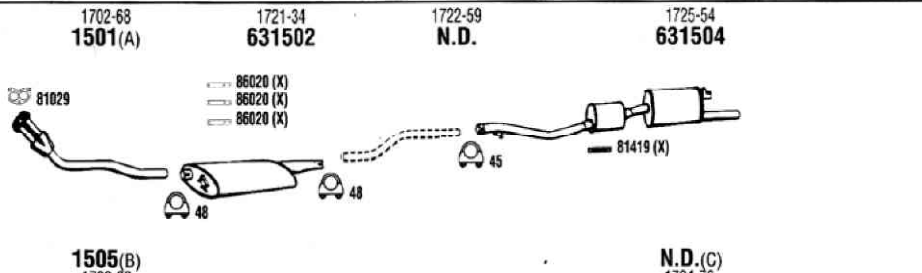

PE50425
504
 2.0
01/68-12/72
 1971 cc - 93 HP - 68 kW
 Mot/Eng: XN1
 ch.no. -1572183
 Type/Typ: 504D11-504D20
 TSN: 364-374

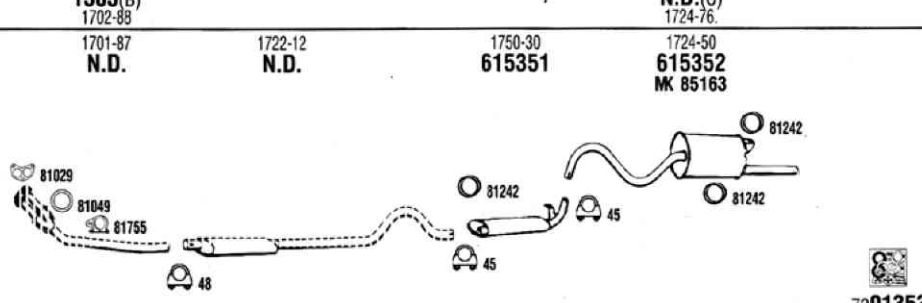

7301353

PE50426
504
 2.0
01/73-06/82
 1971 cc - 93 HP - 68 kW
 Mot/Eng: XN1
 ch.no. 1512184-3791707
 Type/Typ: 504D11-504F11-504F40
 TSN: 364-391

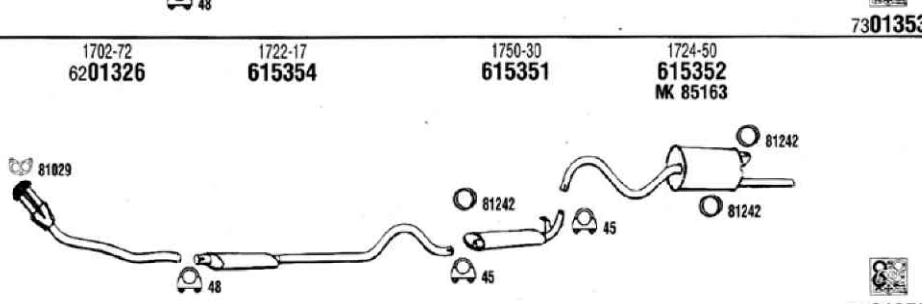

7301353

PE50427
504
 2.0
07/82-12/83
 1971 cc - 93 HP - 68 kW
 Mot/Eng: XN1
 ch.no. 3791708-
 Type/Typ: 504E01-504D11-504F11
 TSN: 364-374

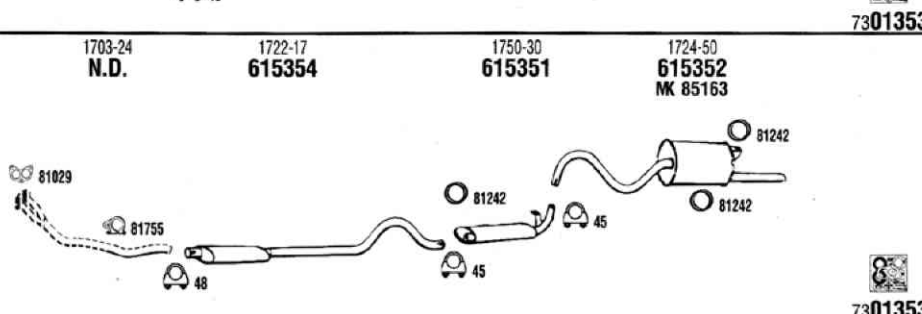

7301353

PE50428
504
Commerciale
 2.0
08/75-06/82
 1971 cc - 93 HP - 68 kW
 Mot/Eng: XN1
 ch.no. -3791707
 Type/Typ: 504E01
 TSN: 409

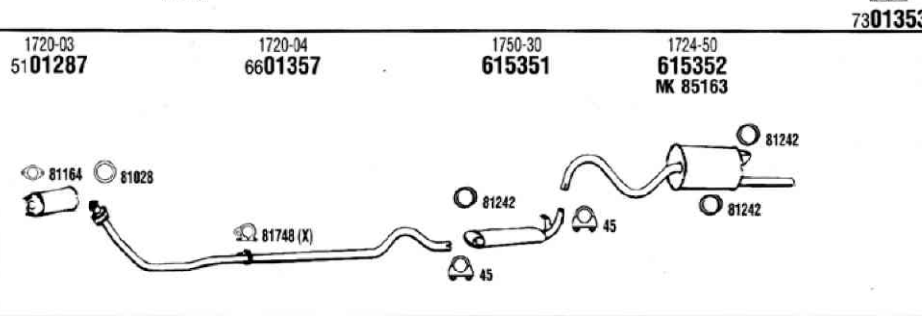

PE50472
504
Commerciale
 2.0
07/82-12/83
 1971 cc - 93 HP - 68 kW
 Mot/Eng: XN1
 ch.no. 3791708-
 Type/Typ: 504E01
 TSN: 409

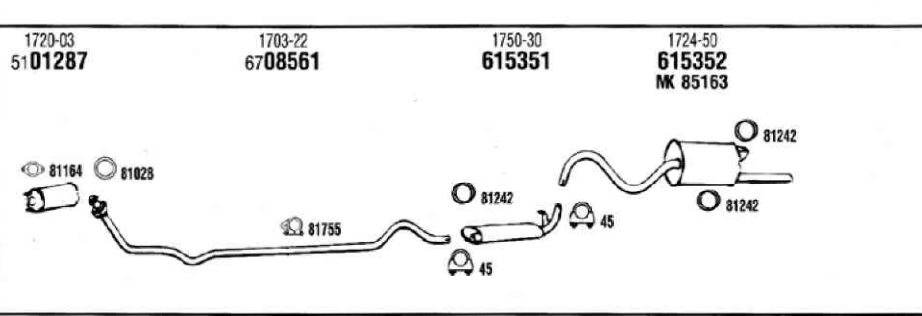

● En desarrollo

Los nombres y números de primer equipo se utilizan solamente como referencia

IMPORTANTE:

Al Al pedir sistemas de escape, rogamos completen la referencia comenzando por 'MFO.' (ejemplo: 381394 → MFO.381394)
 Pour commander echappement, nous vous prions de compléter la référence en commençant par MFO..
 When ordering exhaust, please complete the reference by beginning with MFO..

ESCAPE / ECHAPPEMENT / EXHAUST

Fonos

Peugeot

<p>1792-19 N.D.</p>	<p>1722-18 5101323</p>	<p>1724-68 6501324 MK 85163</p>	<p>504 LD 1.9 Diesel 03/73-07/78 1948 cc - 56 HP - 41 kW Mot/Eng: XD88 ch.no. 2183069-2791703 Type/Typ: 504M20 TSN: 383</p> <p>PE50417</p>
<p>1792-19 N.D.</p>	<p>1722-61 5101424</p>	<p>1724-68 6501324 MK 85163</p>	<p>504 LD-GRD-SRD 1.9 Diesel 08/78-06/79 1948 cc - 56 HP - 41 kW Mot/Eng: XD88 ch.no. 2791704-3201644 Type/Typ: 504M20 TSN: 383</p> <p>PE50418</p>
<p>1703-08 6308565(A)</p>	<p>1792-19 N.D.</p>	<p>1722-61 5101424</p>	<p>504 LD-GRD-SRD 1.9 Diesel 07/79-12/83 1948 cc - 56 HP - 41 kW Mot/Eng: XD88 ch.no. 3201645- (A) ch.no. 3610001-(09/81-)</p> <p>PE50463</p>
<p>1702-60 N.D.</p>	<p>1702-57 N.D.</p>	<p>1725-48 615417</p>	<p>504 Pick up 1.9 Diesel 10/79-06/82 1948 cc - 59 HP - 43 kW Mot/Eng: XD88 ch.no. -3758601 Type/Typ: 504U20-504V20-504V40</p> <p>PE50451</p>
<p>1703-08 6308565</p>	<p>1728-11 6608566</p>	<p>1725-48 615417</p>	<p>504 Pick up 1.9 Diesel 07/82-10/93 1948 cc - 56 HP - 41 kW Mot/Eng: XD88 ch.no. 3758602- Type/Typ: 504U20-504V20-504V40</p> <p>PE50456</p>
<p>1701-89 N.D.</p>	<p>1722-12 N.D.</p>	<p>1750-30 615351</p>	<p>504 Commerciale 1.9 Diesel 01/68-12/72 1948 cc - 56 HP - 41 kW Mot/Eng: XD88 ch.no. -1572183 Type/Typ: 504D11-504D20 TSN: 364-374</p> <p>PE50460</p>

Los nombres y números de primer equipo se utilizan solamente como referencia

● En desarrollo

IMPORTANTE:

Al pedir sistemas de escape, rogamos completen la referencia comenzando por 'MFO.' (ejemplo: 381394 → MFO.381394)

Pour commander echappement, nous vous prions de compléter la référence en commençant par MFO..

When ordering exhaust, please complete the reference by beginning with MFO..

Peugeot

Fonos

504
Commerciale 
 1.9 Diesel
03/73-08/77
 1948 cc - 56 HP - 41 kW
 Mot/Eng: XD88
 ch.no. 1572184-

1701-99 **N.D.** 1722-17 **615354** 1750-30 **615351** 1724-50 **615352**
 MK 85163

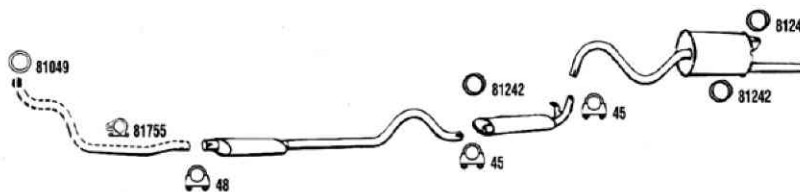

PE50455

504
Commerciale 
 1.9 Diesel
09/77-12/83
 1948 cc - 56 HP - 41 kW
 Mot/Eng: XD88
 ch.no. -3201644
 (A) ch.no. -3201645 (-07/79)
 (B) ch.no. 3201646- (06/79-)

1702-53 **N.D.(A)** 1722-17 **615354** 1750-30 **615351** 1724-50 **615352**
 MK 85163

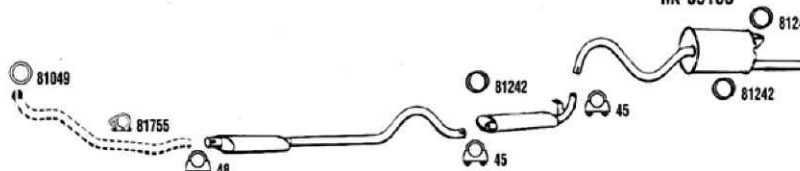

PE50452

504
LD 
 2.1 Diesel
03/73-07/78
 2112 cc - 65 HP - 48 kW
 Mot/Eng: XD90
 ch.no. 2183069-2791703
 Type/Typ: 504M20
 TSN: 360, 403

1792-19 **N.D.** 1722-18 **5101323** 1724-68 **6501324**
 MK 85163

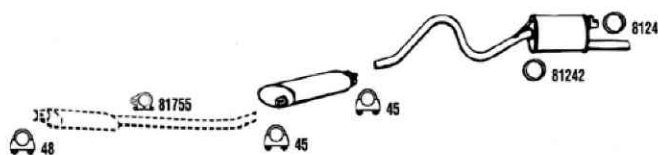

PE50465

504
LD-GRD-SRD 
 2.1 Diesel
08/78-06/79
 2112 cc - 65 HP - 48 kW
 Mot/Eng: XD90
 ch.no. 2791704-3201644
 Type/Typ: 504M40
 TSN: 360, 403

1792-19 **N.D.** 1722-61 **5101424** 1724-68 **6501324**
 MK 85163

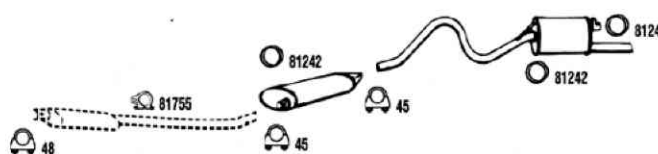

PE50446

504
LD-GRD-SRD 
 2.1 Diesel
07/79-12/83
 2112 cc - 65 HP - 48 kW
 Mot/Eng: XD90
 ch.no. 3201645-
 (A) ch.no. 3610001 - (09/81-)
 TSN: 360, 403

1703-08 **6308565(A)** 1792-19 **N.D.** 1722-61 **5101424** 1724-68 **6501324**
 MK 85163

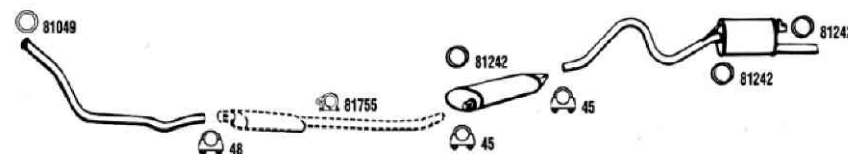

PE50462

504
Pick up 
 2.1 Diesel
10/79-07/82
 2112 cc - 65 HP - 48 kW
 Mot/Eng: XD90
 ch.no. -3758601
 Type/Typ: 504U20-504V20-504V40

1702-60 **N.D.** 1702-57 **N.D.** 1725-48 **615417**



PE50450

● En desarrollo

Los nombres y números de primer equipo se utilizan solamente como referencia

IMPORTANTE:











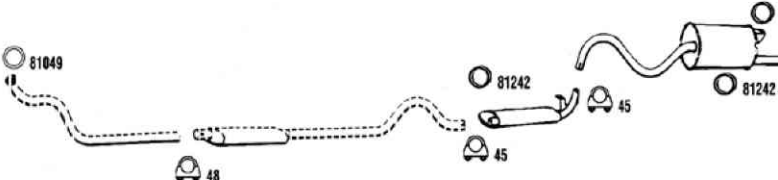

Al pedir sistemas de escape, rogamos completen la referencia comenzando por 'MFO.' (ejemplo: 381394 → MFO.381394)
 Pour commander echappement, nous vous prions de compléter la référence en commençant par MFO..
 When ordering exhaust, please complete the reference by beginning with MFO..

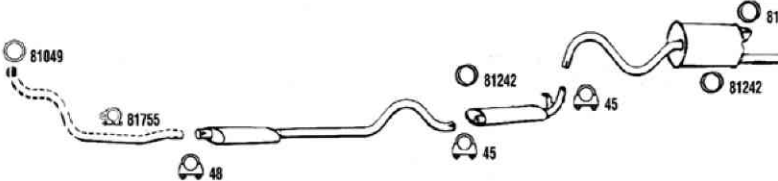
ESCAPE / ECHAPPEMENT / EXHAUST

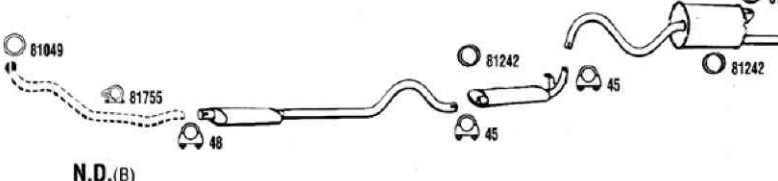
Fonos

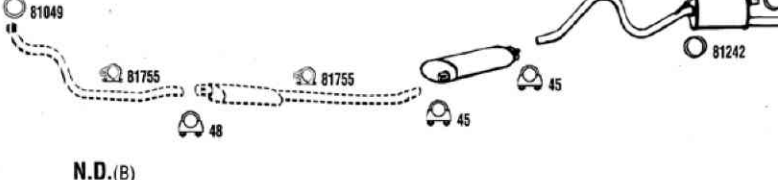
Peugeot

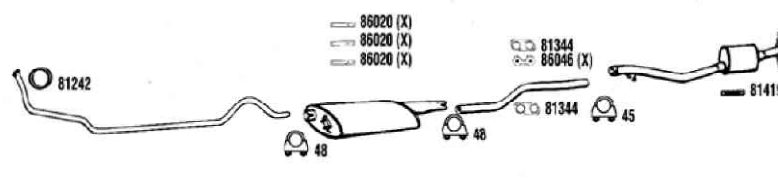
MOTOR / MOTEUR / ENGINE

1703-08 6308565	1728-11 6608566	1725-48 615417		504 Pick up-  2.1 Diesel 07/82-10/93 2112 cc - 65 HP - 48 kW Mot/Eng: XD90 ch.no. 3758602- Type/Typ: 504U20-504V20-504V40 PE50459	
1701-89 N.D.	1722-12 N.D.	1750-30 615351	1724-50 615352 MK 85163		504 Commerciale  2.1 Diesel 01/68-12/72 2112 cc - 65 HP - 48 kW Mot/Eng: XD90 ch.no. -1572183 Type/Typ: 504D11-504D20 TSN: 365, 410 PE50448
1701-99 N.D.	1722-17 615354	1750-30 615351	1724-50 615352 MK 85163		504 Commerciale  2.1 Diesel 03/73-08/77 2112 cc - 65 HP - 48 kW Mot/Eng: XD90 ch.no. 1572184- TSN: 365, 410 PE50457
1702-53 N.D.(A)	1722-17 615354	1750-30 615351	1724-50 615352 MK 85163		504 Commerciale  2.1 Diesel 09/77-12/83 2112 cc - 65 HP - 48 kW Mot/Eng: XD90 (A) ch.no. -3201645 (-06/79) (B) ch.no. 3201646- (07/79-) Type/Typ: 504D40-504F11-504E20-504F20 TSN: 365, 410 PE50458
1701-99 N.D.(A)	1792-19 N.D.	1722-18 5101323	1724-68 6501324 MK 85163		504 LD  2.3 Diesel 03/73-07/78 2304 cc - 70 HP - 51 kW Mot/Eng: XD94 ch.no. 2183069-2791703 (A) ch.no. -2602015 (B) ch.no. 2602016- Type/Typ: 504M20 TSN: 383 PE50466
1703-12 6701481(A)	1721-34 631502	1722-15 31503	1725-54 631504		504 GLD  2.3 Diesel 03/73-07/77 2304 cc - 70 HP - 51 kW Mot/Eng: XD2 ch.no. 1423032-2491542 (A) 07775- Type/Typ: 504A40 TSN: 385 PE50422

Los nombres y números de primer equipo se utilizan solamente como referencia

● En desarrollo

IMPORTANTE:

Al pedir sistemas de escape, rogamos completen la referencia comenzando por 'MFO.' (ejemplo: 381394 → MFO.381394)

Pour commander echappement, nous vous prions de compléter la référence en commençant par MFO..

When ordering exhaust, please complete the reference by beginning with MFO..

Peugeot

Fonos

504

GLD 

2.3 Diesel
09/77-10/82
2304 cc - 70 HP - 51 kW
Mot/Eng: XD2
ch.no. 2491543-
(A) ch.no. 320645-
Type/Typ. 504A40
TSN: 385

PE50423

1703-21
31518(A)

1721-34
631502

1722-15
31503

1725-54
631504

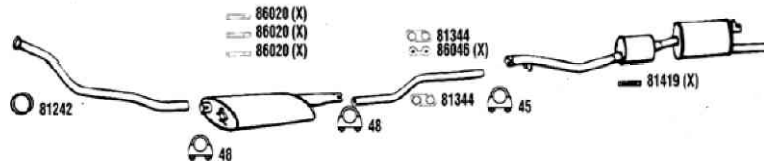

 7301344

504

LD-GRD-SRD 

2.3 Diesel
08/78-06/79
2304 cc - 70 HP - 51 kW
Mot/Eng: XD94
ch.no. 2791704-3201644
Type/Typ. 504M20
TSN: 383

PE50467

1702-53
N.D.

1792-19
N.D.

1722-61
5101424

1724-68
6501324
MK 85163

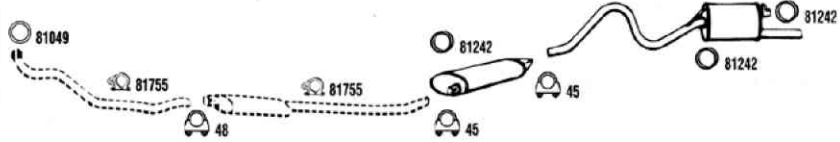

504

LD-GRD-SRD 

2.3 Diesel
07/79-12/83
2304 cc - 70 HP - 51 kW
Mot/Eng: XD94
ch.no. 3201645-
(A) ch.no. 3610001 - (09/81)

PE50468

1703-08
6308565(A)

1792-19
N.D.

1722-61
5101424

1724-68
6501324
MK 85163

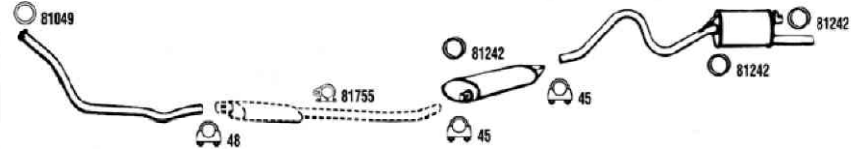

504

Pick up 

2.3 Diesel
10/79-06/82
2304 cc - 70 HP - 51 kW
Mot/Eng: XD94
ch.no. -3758601
Type/Typ. 504U20-504V20-504V40

PE50436

1702-60
N.D.

1702-57
N.D.

1725-48
615417



504

Pick up -  - Dangel

2.3 Diesel
07/82-94
2304 cc - 70 HP - 51 kW
Mot/Eng: XD94
ch.no. 3758602-
Type/Typ. 504U20-504V20-504V40

PE50437

1703-08
6308565

1728-11
6608566

1725-48
615417



504

Commerciale 

2.3 Diesel
01/68-12/72
2304 cc - 70 HP - 51 kW
Mot/Eng: XD94
ch.no. -1572183
Type/Typ. 504D11-504D20
TSN: 364-374

PE50449

1701-89
N.D.

1722-12
N.D.

1750-30
615351

1724-50
615352
MK 85163

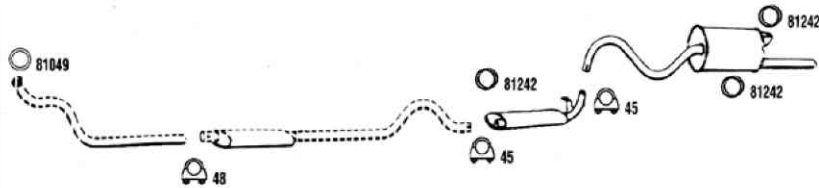

● En desarrollo

Los nombres y números de primer equipo se utilizan solamente como referencia







IMPORTANTE:

Al Al pedir sistemas de escape, rogamos completen la referencia comenzando por 'MFO.' (ejemplo: 381394 → MFO.381394)
Pour commander echappement, nous vous prions de compléter la référence en commençant par MFO..
When ordering exhaust, please complete the reference by beginning with MFO..

ESCAPE / ECHAPPEMENT / EXHAUST

Fonos

Peugeot

1701-99 N.D.	1722-17 615354	1750-30 615351	1724-50 615352 MK 85163	504 Commerciale  2.3 01/73-08/77 2304 cc - 70 HP - 51 kW Mot/Eng: XD94 ch.no. 1572184- Type/Typ: 504D40-504F11-504E20-504F20 TSN: 406-408 PE50454
1702-53 N.D.(A)	1722-17 615354	1750-30 615351	1724-50 615352 MK 85163	504 Commerciale  2.3 Diesel 09/77-12/83 2304 cc - 70 HP - 51 kW Mot/Eng: XD94 (A) ch.no. -3201645 (-06/79) (B) ch.no. 3201646- (07/79-) Type/Typ: 504D40-504F11-504E20-504F20 TSN: 406-408 PE50430
1702-60 N.D.	1702-57 N.D.	1725-48 615417		504 4x4 Dangel Pick up  2.3 Diesel 10/79-06/82 2304 cc - 70 HP - 51 kW Mot/Eng: XD94 PE50405
1703-08 6308565	1728-11 6608566	1725-48 615417		504 4x4 Dangel Pick up  2.3 Diesel 07/82-12/83 2304 cc - 70 HP - 51 kW Mot/Eng: XD94 PE20024
1702-79 N.D.	1722-17 615354	1750-30 615351	1724-50 615352 MK 85163	504 4x4 Dangel Familiale  2.3 Diesel 10/79-06/82 2304 cc - 70 HP - 51 kW Mot/Eng: XD94 PE71502
1703-08 6308565	1722-17 615354	1750-30 615351	1724-50 615352 MK 85163	504 4x4 Dangel Familiale  2.3 Diesel 07/82-12/83 2304 cc - 70 HP - 51 kW Mot/Eng: XD94 PE50006

Los nombres y números de primer equipo se utilizan solamente como referencia

● En desarrollo

IMPORTANTE:

Al pedir sistemas de escape, rogamos completen la referencia comenzando por 'MFO.' (ejemplo: 381394 → MFO.381394)

Pour commander echappement, nous vous prions de compléter la référence en commençant par MFO..

When ordering exhaust, please complete the reference by beginning with MFO..

Info 505



Diesel: ch.no. 1126778-1495101
Diesel: ch.no. 1126778-1578000

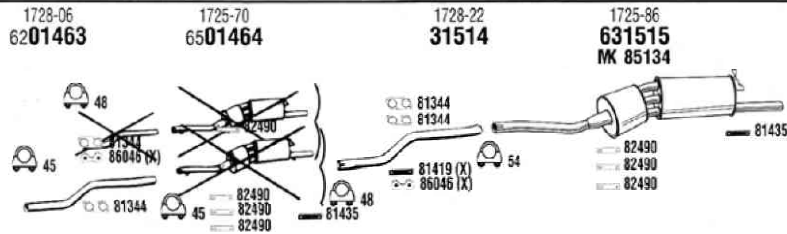

PE50503

505



GL
1.8
05/79-08/80
1796 cc - 79 HP - 58 kW
Mot/Eng: XM7P (single valve carb.)
ch.no. -1126777
(A) (S)
Type/Typ: 551A01-551A03

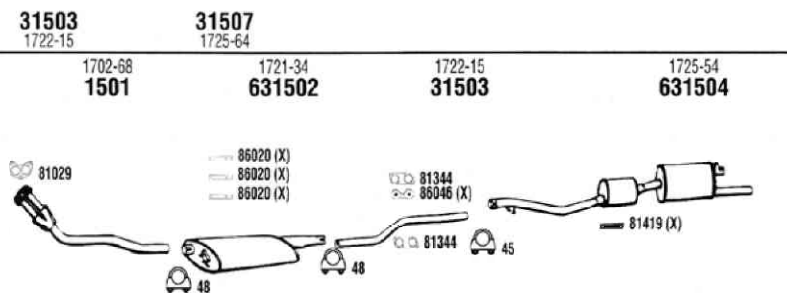

PE50508

505



GL
1.8
09/80-06/83
1796 cc - 79 HP - 58 kW
Mot/Eng: XM7P (single valve injection)
ch.no. 1126778-1495101
Type/Typ: 551A01-551A03-551A71
TSN: 442

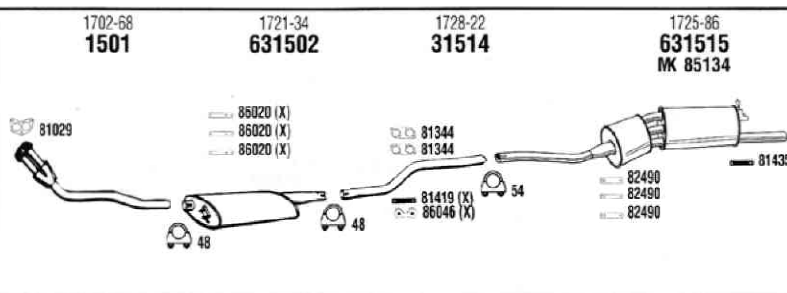

PE50509

505



GL
1.8
07/83-06/85
1796 cc - 79 HP - 58 kW
Mot/Eng: XM7P (single valve injection)
ch.no. 1495102-1807897
Type/Typ: 551A01-551A03-551A71-551A73
TSN: 442-467

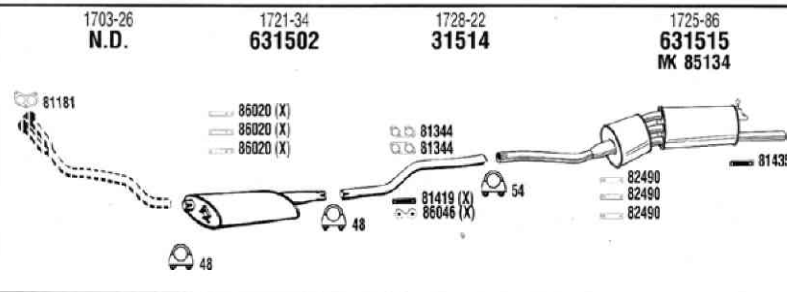

7308587

PE50510

505



GL-SL-GR-SR
1.8
07/85-11/87
1796 cc - 90 HP - 66 kW
Mot/Eng: XM7A (single valve injection)
ch.no. 1807898-
Type/Typ: 551A73/1-551A77/A1-551A77/1
TSN: 491

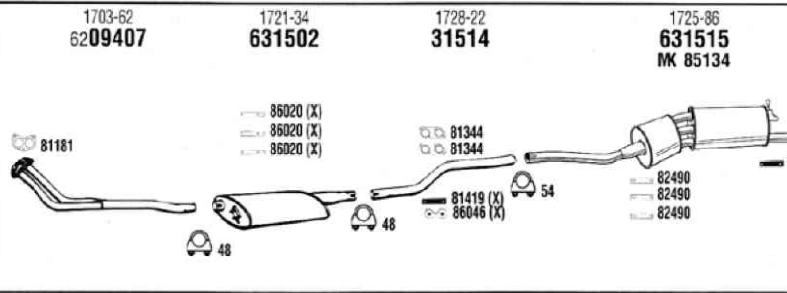

7312832

PE71603

505



GL-GR-SL-SR-SX-ST
1.8
12/87-12/91
1796 cc - 90 HP - 66 kW
Mot/Eng: XM7A (single valve inj)
Type/Typ: 551A73/1/77/113.1/17.1/18.1

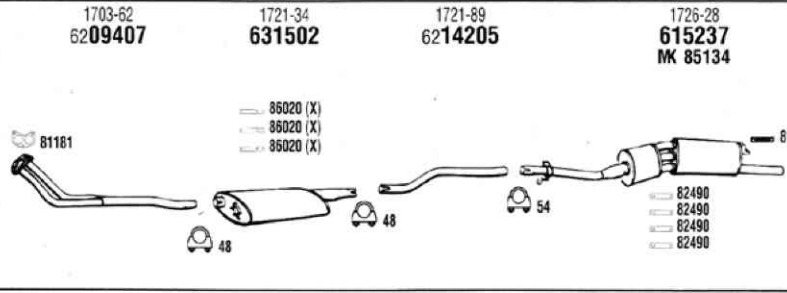

7312833

PE50527

● En desarrollo

Los nombres y números de primer equipo se utilizan solamente como referencia

IMPORTANTE:

Al pedir sistemas de escape, rogamos completen la referencia comenzando por 'MFO.' (ejemplo: 381394 → MFO.381394)
Pour commander echappement, nous vous prions de compléter la référence en commençant par MFO..
When ordering exhaust, please complete the reference by beginning with MFO..

ESCAPE / ECHAPPEMENT / EXHAUST

Fonos

Peugeot

1721-25 N.D.(A)	1703-12 6701481(A)	1728-07 5201482	1725-74 615483
--------------------	-----------------------	--------------------	-------------------

7301485

505
 -Familiale
 1.8
02/82-06/85
 1796 cc - 79 HP - 58 kW
 Mot/Eng: XM7P (single valve 4v)
 ch.no. -1845000
 (A)
 Type/Typ: 551D01/11/13/17/G1/G7-
 Type/Typ: 551F01/F11/F13/F17/F81/G11/G17
 PE50595

1703-79 N.D.	1728-09 N.D.	1728-17 615497	1725-82 615498
-----------------	-----------------	-------------------	-------------------

PE72117

505
 -Familiale
 1.8
07/85-12/90
 1796 cc - 90 HP - 66 kW
 Mot/Eng: XM7A (single valve 4v)
 ch.no. 1845001-
 Type/Typ: 551D71.1/73.1/77.1/77.1/77.1
 PE72117

1702-88 1505	1721-34 631502	1722-15 31503	1725-54 631504
-----------------	-------------------	------------------	-------------------

7301401

505
 -SR
 2.0
05/79-08/80
 1971 cc - 96 HP - 71 kW
 Mot/Eng: XN1A (double valve 4v)
 ch.no. -1126777
 Type/Typ: 551A11-551A13
 TSN: 416
 PE50511

1702-88 1505	1721-34 631502	1728-22 31514	1725-86 631515 MK 85134
-----------------	-------------------	------------------	-------------------------------

7308587

505
 -GL-GR-SR
 2.0
09/80-06/85
 1971 cc - 96 HP - 71 kW
 Mot/Eng: XN1A (double valve 4v)
 ch.no. 1126778-1807897
 07/81-06/83
 Type/Typ: 551A11-551A17-551A13
 TSN: 416
 PE50513

1703-82 6209407	1721-34 631502	1721-89 6214205	1726-28 615237 MK 85134
--------------------	-------------------	--------------------	-------------------------------

7312833

505
 -GL-GR-SL-SR-SX-ST
 2.0
12/87-12/91
 1971 cc - 96 HP - 71 kW
 Mot/Eng: XN1A (double valve 4v)
 Type/Typ: 551A73/71/77/13.1/17.1/18.1
 PE50544

N.D.(A)	1721-34 631502	1728-22 31514	1725-86 631515 MK 85134
---------	-------------------	------------------	-------------------------------

7308587

505
 -GL-GR-SR
 2.0
07/83-06/85
 1971 cc - 96 HP - 71 kW
 Mot/Eng: XN1A (double valve carb.)
 ch.no. -1807897
 (A)
 Type/Typ: 551A11-551A13-551A17
 PE50537

Los nombres y números de primer equipo se utilizan solamente como referencia

● En desarrollo

IMPORTANTE:

Al pedir sistemas de escape, rogamos completen la referencia comenzando por 'MFO.' (ejemplo: 381394 → MFO.381394)
 Pour commander echappement, nous vous prions de compléter la référence en commençant par MFO..
 When ordering exhaust, please complete the reference by beginning with MFO..

MOTOR / MOTEUR / ENGINE

505
GL-GR-SR 
 2.0
07/85-11/87
 1971 cc - 96 HP - 71 kW
 Mot/Eng: XN1A (double valve inj)
 ch.no. 1807898-
 (A) 
 Type/Typ: 551A11.1/13.1/17.1/18.1
 TSN: 490

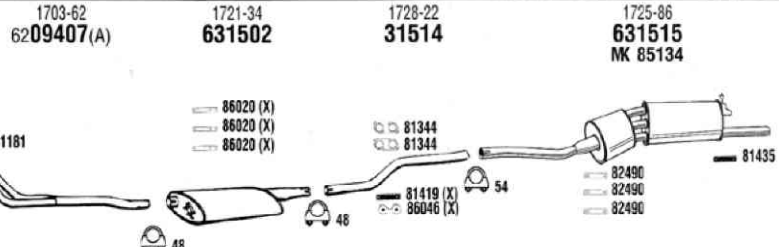

7312832

505
GL-SR  
 2.0
07/85-11/86
 1971 cc - 108 HP - 79 kW
 Mot/Eng: XN1A (double valve carb.)
 ch.no. 1807898-
 Type/Typ: 551A11-551A13-551A17-551A18

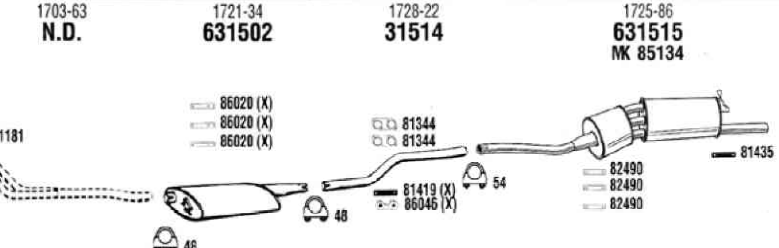

7308587

505
-Familiale  
 2.0
02/82-06/85
 1971 cc - 82, 94 HP - 60, 69 kW
 Mot/Eng: XN1A (double valve inj)
 ch.no. -1845000
 Type/Typ: 551D01/11/13/17/G1/G7
 Type/Typ: 551F01/F11/F13/F17/F81/G11/G17

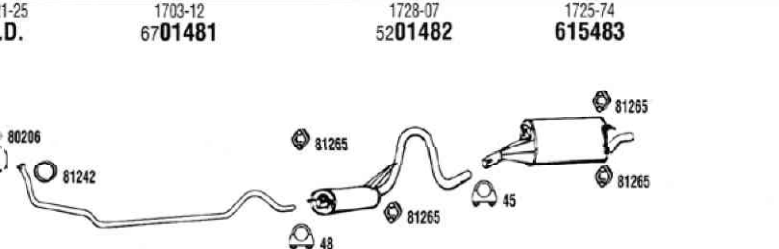

7301485

505

 2.0
02/82-06/85
 1971 cc - 96 HP - 71 kW
 Mot/Eng: XN1A (double valve carb.)
 ch.no. -1845000
 Type/Typ: 551D01/11/13/17/G1/G7
 Type/Typ: 551F01/11/13/17/81-G11/17

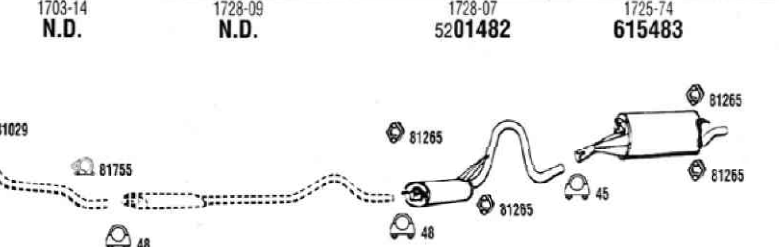

7309651

505
GL-GR -Familiale  
 2.0
07/85-12/90
 1971 cc - 96 HP - 71 kW
 Mot/Eng: XN1A (double valve carb.)
 ch.no. 1845001-
 (A) 
 Type/Typ: 551D17-551D13-551F17-551F13
 TSN: 492

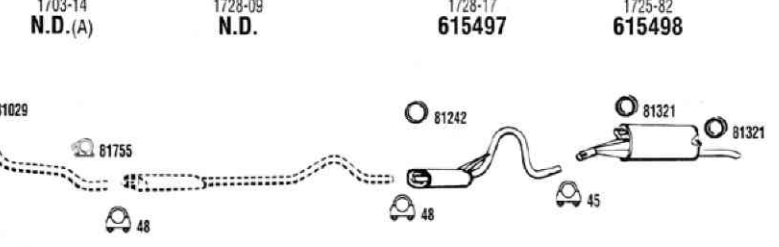

7312870

505
GL-GR-Dangel  **-Fam.**
 2.0 incl. 4x4
07/85-12/90
 1971 cc - 96 HP - 71 kW
 Mot/Eng: XN1A (double valve inj)
 ch.no. 1845001-
 Type/Typ: 551D11.1/17.1/18.1-G11.1/13.1-
 Type/Typ: 551F11.1/13.1/17.1/18.1/B1.1
 TSN: 492

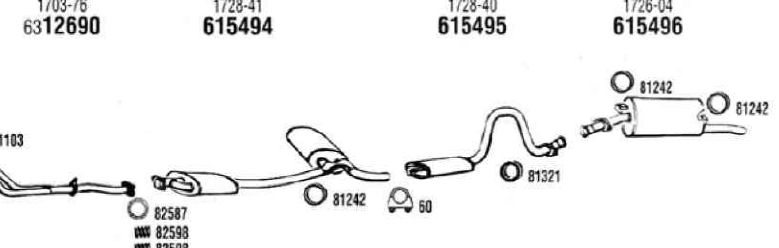

7312870

● En desarrollo Los nombres y números de primer equipo se utilizan solamente como referencia

IMPORTANTE:

Al pedir sistemas de escape, rogamos completen la referencia comenzando por 'MFO.' (ejemplo: 381394 → MFO.381394)
 Pour commander echappement, nous vous prions de compléter la référence en commençant par MFO..
 When ordering exhaust, please complete the reference by beginning with MFO..

ESCAPE / ECHAPPEMENT / EXHAUST

Fonos

Peugeot

1721-34 631502	1722-15 31503	1725-54 631504	<p>86020 (X) 86020 (X) 86020 (X)</p> <p>81344 86046 (X)</p> <p>81419 (X)</p> <p>48 48 45</p>	<p>505</p> <p>Ti-STi </p> <p>2.0i</p> <p>05/79-08/80</p> <p>1995 cc - 110 HP - 81 kW</p> <p>Mot/Eng: ZEJ</p> <p>ch.no. -1126777</p> <p>Type/Typ: 551A12-551A14-551A16</p> <p>TSN: 417</p> <p>PE50521</p>	
1721-34 631502	1726-22 31514	1725-86 631515 MK 85134	<p>86020 (X) 86020 (X) 86020 (X)</p> <p>81344 81344</p> <p>81419 (X) 86046 (X)</p> <p>82490 82490 82490</p> <p>81435</p> <p>48 48 54</p>	<p>505</p> <p>Ti-STi </p> <p>2.0i</p> <p>09/80-06/81</p> <p>1995 cc - 110 HP - 81 kW</p> <p>Mot/Eng: ZEJ</p> <p>ch.no. 1126778-1290000</p> <p>Type/Typ: 551A12-551A14-551A16</p> <p>TSN: 417</p> <p>PE50525</p>	
1703-05 N.D.	1721-34 631502	1728-22 31514	1725-86 631515 MK 85134	<p>81181</p> <p>86020 (X) 86020 (X) 86020 (X)</p> <p>81344 81344</p> <p>81419 (X) 86046 (X)</p> <p>82490 82490 82490</p> <p>81435</p> <p>48 48 54</p>	<p>505</p> <p>Ti-STi </p> <p>2.0i</p> <p>07/81-11/87</p> <p>1995 cc - 110 HP - 81 kW</p> <p>Mot/Eng: ZEJ</p> <p>ch.no. 1292001-1807897</p> <p>Type/Typ: 551A12-551A14-551A16</p> <p>TSN: 417</p> <p>7312833 PE50590</p>
1703-68 N.D.	1721-34 631502	1721-89 6214205	1726-28 615237 MK 85134	<p>81181</p> <p>86020 (X) 86020 (X) 86020 (X)</p> <p>81419 (X)</p> <p>82490 82490 82490 82490</p> <p>81435</p> <p>48 48 54</p>	<p>505</p> <p>Ti-STi </p> <p>2.0i</p> <p>12/87-12/93</p> <p>1995 cc - 110 HP - 81 kW</p> <p>Mot/Eng: ZEJ</p> <p>ch.no. 1807898-</p> <p>Type/Typ: 551A16-551A19</p> <p>7312833 PE50532</p>
1703-66 N.D.(A)	1721-34 631502	1721-89 6214205	1726-28 615237 MK 85134	<p>86020 (X) 86020 (X) 86020 (X)</p> <p>81419 (X)</p> <p>82490 82490 82490 82490</p> <p>81435</p> <p>48 48 54</p>	<p>505</p> <p>GR </p> <p>2.2</p> <p>07/85-12/90</p> <p>2165 cc - 123 HP - 90 kW</p> <p>Mot/Eng: ZDJL</p> <p>(A) </p> <p>Type/Typ: 551A86-551A89-551A84</p> <p>7312833 PE50528</p>
1703-04 N.D.	1721-34 631502	1728-22 31514	1725-86 631515 MK 85134	<p>81181</p> <p>86020 (X) 86020 (X) 86020 (X)</p> <p>81344 81344</p> <p>81419 (X) 86046 (X)</p> <p>82490 82490 82490</p> <p>81435</p> <p>48 48 54</p>	<p>505</p> <p></p> <p>2.2 GTi</p> <p>07/81-06/83</p> <p>2165 cc - 117 HP - 88 kW</p> <p>Mot/Eng: ZDJ</p> <p>ch.no. 1292001-1495101</p> <p>Type/Typ: 551A34-551A36</p> <p>TSN: 439</p> <p>7312833 PE50522</p>

Los nombres y números de primer equipo se utilizan solamente como referencia

● En desarrollo

IMPORTANTE:

Al pedir sistemas de escape, rogamos completen la referencia comenzando por 'MFO.' (ejemplo: 381394 → MFO.381394)

Pour commander echappement, nous vous prions de compléter la référence en commençant par MFO..

When ordering exhaust, please complete the reference by beginning with MFO..

Peugeot

Fonos

MOTOR / MOTEUR / ENGINE

505

2.2 GTi
07/81-06/83
2165 cc - 117 HP - 88 kW
Mot/Eng: ZEK
ch.no. 1292001-1495101
Type/Typ: 551A34-551A36
TSN: 417

1703-05 N.D. 1721-34 631502 1728-22 31514 1725-86 631515 MK 85134

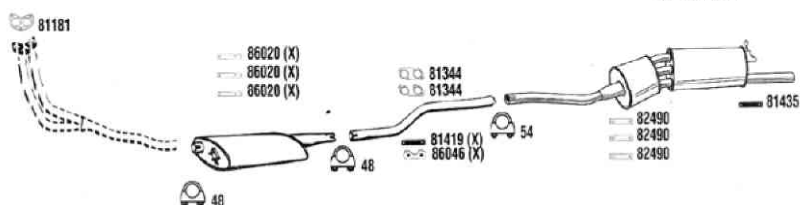

7312833

PE50591

505

2.2 GTi
07/83-06/85
2165 cc - 130 HP - 96 kW
Mot/Eng: ZDJL
ch.no. -1807897
Type/Typ: 551A84-551A86
TSN: 417-469

1703-42 N.D. 1721-34 631502 1728-22 31514 1725-86 631515 MK 85134

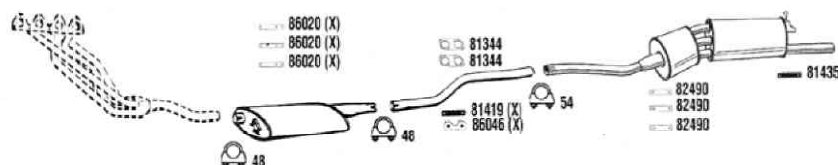

PE50523

505

2.2 GTi
07/85-11/87
2165 cc - 130 HP - 96 kW
Mot/Eng: ZDJL
ch.no. 1807898-
Type/Typ: 551A84-551A86-551A89
TSN: 469

1703-67 N.D. 1721-34 631502 1728-22 31514 1725-86 631515 MK 85134

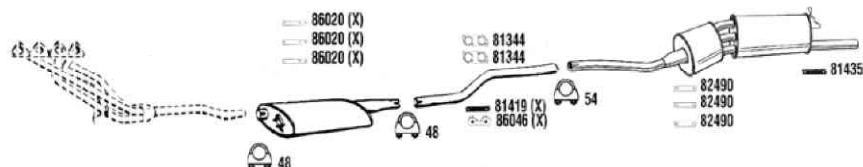

PE20037

505

2.2 GTi
12/87-05/90
2165 cc - 130 HP - 96 kW
Mot/Eng: ZDJL ch.no. -3108178 (-12/88)
Mot/Eng: ZDJ ch.no. 3108179- (01/89-)
ch.no. -3191255 Autom.: -3192430 Autom
Type/Typ: 551A84-551A86-551A89
TSN: 469

1703-67 N.D. 1721-34 631502 1721-89 6214205 1726-28 615237 MK 85134

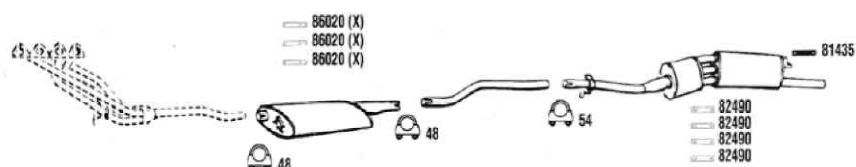

PE50538

505

GR-GL-GTi
2.2i
01/86-12/90
2165 cc - 115 HP - 84 kW
Mot/Eng: ZDJL
Type/Typ: 551A
TSN: 211

1703-90 N.D. 1721-62 N.D.CAT 1721-80 N.D. 1726-28 615237 MK 85134



PE50593

CAT

505

2.2i Turbo
03/83-09/88
2165 cc - 167 HP - 123 kW
Mot/Eng: N9TE
(A)
Type/Typ: 551A66-551A96-551A99
TSN: 209-470

λ1 87854 87910 1703-36 N.D.(A) 1717-04 31520¹ 1728-15 31521¹ 1724-11 631522¹ MK 85736

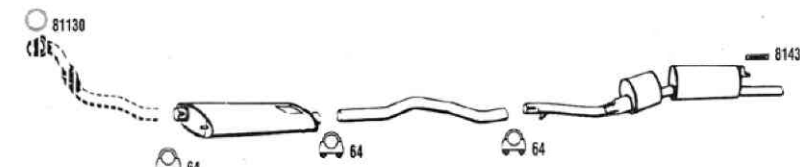

7308589

PE50531

● En desarrollo

Los nombres y números de primer equipo se utilizan solamente como referencia

IMPORTANTE:

Al pedir sistemas de escape, rogamos completen la referencia comenzando por 'MFO.' (ejemplo: 381394 → MFO.381394)
Pour commander echappement, nous vous prions de compléter la référence en commençant par MFO..
When ordering exhaust, please complete the reference by beginning with MFO..

ESCAPE / ECHAPPEMENT / EXHAUST

Fonor

Peugeot

1703-56 N.D.(A)	1717-04 31520 ¹	1728-15 31521 ¹	1724-11 631522 ¹ MK 85736	505 2.2i Turbo 07/83-09/88 2165 cc - 167 HP - 123 kW Mot/Eng: N9TE (A) Type/Typ: 551A66-551A96-551A99
--------------------	-------------------------------	-------------------------------	--	---

7308589 PE50535

N.D.	N.D.CAT	N.D.	1724-11 631522 ¹ MK 85736	505 2.2i Turbo 10/86-09/88 2155 cc - 174 HP - 128 kW Mot/Eng: N9TE TSN: 247
------	---------	------	--	--

PE50539 **CAT**

1703-90 N.D.	1721-55 N.D.CAT	1728-42 N.D.	1728-40 615495	1726-04 615496	505 GL-GR-GTi Familiale 2.2i 09/86-12/91 2165 cc - 115 HP - 84 kW Mot/Eng: ZDJL TSN: 215
-----------------	--------------------	-----------------	-------------------	-------------------	---

PE50536 **CAT**

1703-82 6312492(A)	1728-41 615494	1728-40 615495	1726-04 615496	505 GTi-Dangel -Familiale 2.2i Excl. 4x4 07/85-12/90 2165 cc - 130 HP - 96 kW Mot/Eng: ZDJL (A) R.H.D. Type/Typ: 551D16.1/66/89-F16.1/86/89 TSN: 493
-----------------------	-------------------	-------------------	-------------------	---

7312872 PE72123

1703-21 31518	1721-34 631502	1722-15 31503	1725-54 631504	505 GRD-SRD 2.3 Diesel 07/79-08/80 2304 cc - 70 HP - 51 kW Mot/Eng: XD2 ch.no. -1126777 (A) Type/Typ: 551A40-551A45-551A48 TSN: 418
------------------	-------------------	------------------	-------------------	---

7301344 PE50541

1703-21 31518	1721-34 631502	1728-22 31514	1725-86 631515 MK 85134	505 GLD-GRD 2.3 Diesel 09/80-06/85 2304 cc - 70 HP - 51 kW Mot/Eng: XD2 ch.no. 1126778-1807897 Type/Typ: 551A40-551A45-551A48 TSN: 418
------------------	-------------------	------------------	-------------------------------	---

7308590 PE50543

Los nombres y números de primer equipo se utilizan solamente como referencia

● En desarrollo

IMPORTANTE:

Al pedir sistemas de escape, rogamos completen la referencia comenzando por 'MFO.' (ejemplo: 381394 → MFO.381394)
 Pour commander echappement, nous vous prions de compléter la référence en commençant par MFO..
 When ordering exhaust, please complete the reference by beginning with MFO..

MOTOR / MOTEUR / ENGINE

Peugeot

Fonos

505
GLD-SRD 
 2.3 Diesel
02/82-06/85
 2304 cc - 70 HP - 51 kW
 Mot/Eng: XD2
 ch.no. -1845000
 Type/Typ: 551D40/48/50/58/H8/55
 Type/Typ: 551F40/50/58, 551G58
 TSN: 450

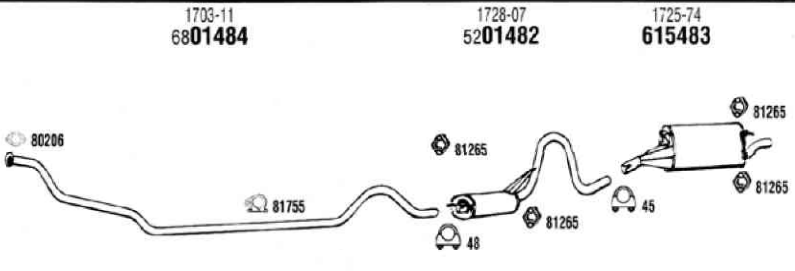

7301485

PE50571

505
SRD-GRD 
 2.3 TD
10/80-07/85
 2304 cc - 80 HP - 59 kW
 Mot/Eng: XD2S
 ch.no. -1814434
 Type/Typ: 551A44-551A46
 TSN: 438

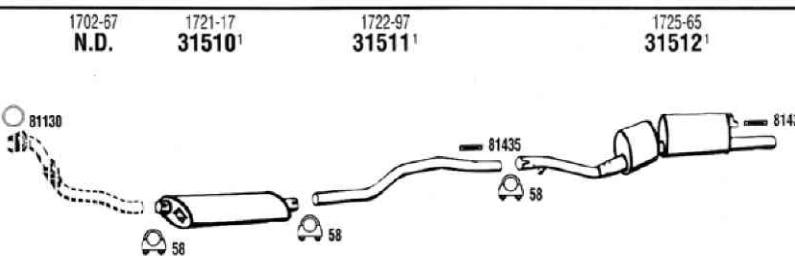

7301485

PE50551

505
GLD-GRD 
 2.5 Diesel
07/81-06/85
 2498 cc - 69, 76 HP - 51, 56 kW
 Mot/Eng: XD3
 ch.no. 12920001-1807897
 Type/Typ: 551A50-551A58-551A59
 TSN: 441, 223

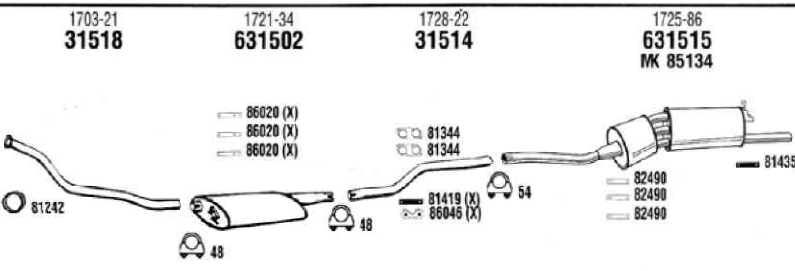

7308590

PE50592

505
GLD-GRD 
 2.5 Diesel
07/85-11/87
 2498 cc - 69, 76 HP - 51, 56 kW
 Mot/Eng: XD3
 ch.no. 1807898
 Type/Typ: 551A50-551A55-551A57-551A58
 TSN: 441, 223

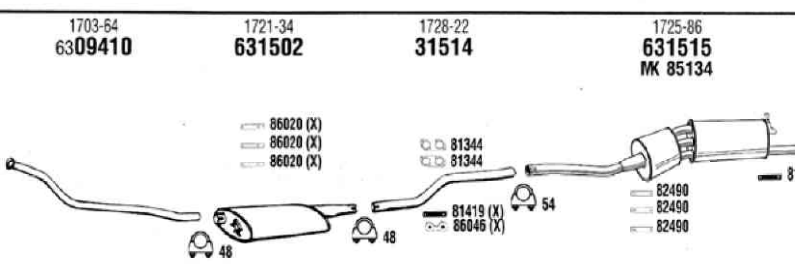

7308590

PE71904

505
GLD-GRD-SXD 
 2.5 Diesel
12/87-12/90
 2498 cc - 70 HP - 51 kW
 Mot/Eng: XD3
 Type/Typ: 551A50/55/57/58/58A
 TSN: 223

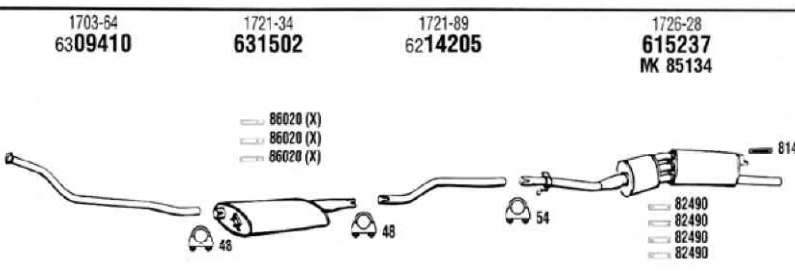

7308590

PE50594

505
GLD-SRD 
 2.5 Diesel
02/82-06/85
 2498 cc - 76 HP - 56 kW
 Mot/Eng: XD3
 ch.no. -1845000
 Type/Typ: 551D40/48/50/58/H8/55
 Type/Typ: 551F40/50/58, 551G58
 TSN: 226-450

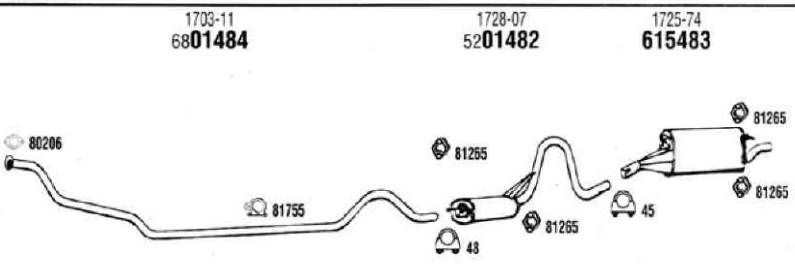

7301485

● En desarrollo

Los nombres y números de primer equipo se utilizan solamente como referencia

IMPORTANTE:

Al pedir sistemas de escape, rogamos completen la referencia comenzando por 'MFO.' (ejemplo: 381394 → MFO.381394)
 Pour commander echappement, nous vous prions de compléter la référence en commençant par MFO..
 When ordering exhaust, please complete the reference by beginning with MFO..

ESCAPE / ECHAPPEMENT / EXHAUST

Fonos

Peugeot

MOTOR / MOTEUR / ENGINE

1703-74 N.D.	1728-39 6512443(A)	1728-17 615497	1725-82 615498(A)	<p>82598 82598 82567 82598 82598 82567 81242 48 81321 45 81321</p>	<p>505 -Familiale 2.5 Diesel 07/85-12/91 2498 cc - 76 HP - 58 kW Mot/Eng: XD3 ch.no. 1845001- (A) excl. 4x4 Dangel Type/Typ: 551D50/55/57/58/H8- Type/Typ: 551F50/57/58-551G58 - TSN: 226-450</p>
1703-39 N.D.	1717-04 31520 ¹	1728-15 31521 ¹	1724-11 631522 ¹ NK 85736	<p>81130 64 64 64 81435</p>	<p>505 2.5 GTD TD 07/83-06/85 2498 cc - 90 HP - 66 kW Mot/Eng: XD3T ch.no. -1814434 (A) R.H.D Type/Typ: 551A54-551A56-551A59 TSN: 468</p>
N.D. (A) 1703-40	1703-96 N.D.	1721-56 N.D.	1724-11 631522 ¹ NK 85736	<p>81434 64 81435</p>	<p>505 SRD-GTD 2.5 TD 07/85-11/87 2498 cc - 90,105 HP - 66,77 kW Mot/Eng: XD3T-XD3TE ch.no. 1814435-1965000 Type/Typ: 551A54-551A56-551A59-551A59/1 TSN: 224-468</p>
1703-96 N.D.	1721-91 5214216	1728-15 31521 ¹	1726-29 6514218 NK 85736	<p>64 64 64 81435</p>	<p>505 GTD-GRD-SRD-STD 2.5 TD 12/87-12/90 2498 cc - 110 HP - 81 kW Mot/Eng: XD3T (A) Intercooler Type/Typ: 551A56/56.1-/56.A/59/59.1 TSN: 224</p>
N.D. (A) 1704-05	1703-75 N.D.	1728-41 615494	1728-40 615495	<p>14701 (X) 82598 82598 82587 81242 60 81321 81242 81242</p>	<p>505 2.5 TD 07/85-06/86 2498 cc - 95 HP - 70 kW Mot/Eng: XD3T ch.no. 1814435-1965000 Type/Typ: 551D59-551D59/1-551F59-551F59/ TSN: 494</p>
1704-06 N.D.	1728-41 615494	1728-40 615495	1726-05 5212694	<p>14701 (X) 82598 82598 82587 81242 60 81321 81242 81242</p>	<p>505 -Familiale 2.5 TD 07/86-12/90 2498 cc - 105 HP - 77 kW Mot/Eng: XD3T ch.no. 1965001- Type/Typ: 551D59.1-551F59.1 TSN: 227</p>

Los nombres y números de primer equipo se utilizan solamente como referencia

● En desarrollo

IMPORTANTE:

Al pedir sistemas de escape, rogamos completen la referencia comenzando por 'MFO.' (ejemplo: 381394 → MFO.381394)

Pour commander echappement, nous vous prions de compléter la référence en commençant par MFO..

When ordering exhaust, please complete the reference by beginning with MFO..

605
SL
 2.0
10/89-07/92
 1998 cc - 115 HP - 85 kW
 Mot/Eng: XU102C
 Type/Typ: 6BR2A2-A8

1704-82
815503

1726-E7
615504

1726-46
615505
 MK 85152

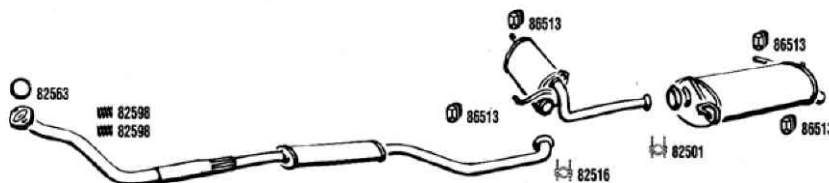

7315506

605
SRI-SVi
 2.0i 8v incl. Autom.
10/89-07/92
 1998 cc - 128, 130 HP - 94, 96 kW
 Mot/Eng: XU10J2 (Multi Point Inj.)
 Type/Typ: 6BR6A2-6BR6A4-6BR6A8

1704-82
815503

1726-E7
615504

1726-46
615505
 MK 85152

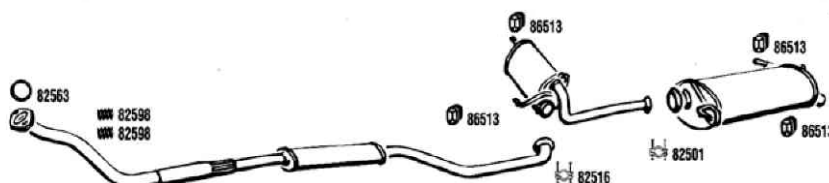

7315506

605
SL
 2.0i
10/89-95
 1998 cc - 110 HP - 81 kW
 Mot/Eng: XU10M (Multi Point Inj.)
 Type/Typ: 6BRDZ2
 TSN: 639

1704-84
9220387CAT
 MK 18473

1728-82
615284

1726-E7
615504

1726-46
615505
 MK 85152

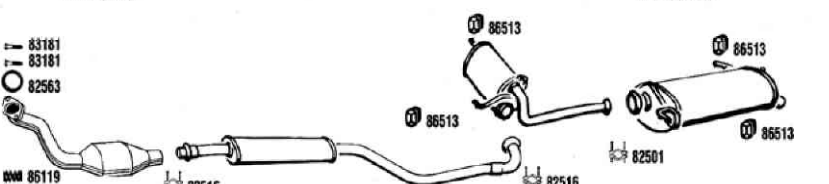

7317185

PE60516 **CAT**

605
SLi-SRi
 2.0i 8v
10/90-06/94
 1998 cc - 121, 128 HP - 89, 94 kW
 Mot/Eng: XU10J2/J2Z(RFZ)(R6A)
 Type/Typ: 6BRFZ2/Z8/Z9-6BR6A2
 TSN: 639

1704-84
9220387CAT
 MK 18473

1728-82
615284

1726-E7
615504

1726-46
615505
 MK 85152

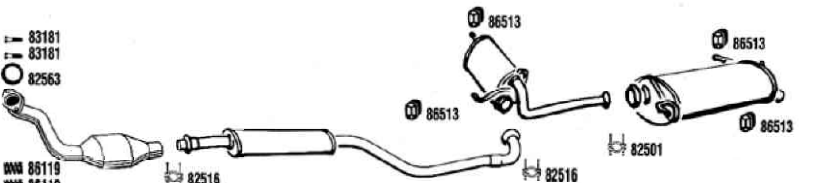

7317185

PE60520 **CAT**

605
SLi - SRi
 2.0i 8v incl. Autom.
10/90-06/94
 1998 cc - 123 HP - 89 kW
 Mot/Eng: XU10J2/J2Z (Multi Point Inj.)
 (A)= Autom.
 Type/Typ: 6BRFZ8-6BRFZ4
 TSN: 639

1705-71
N.D.CAT

1728-82
615284

1726-E7
615504

1726-46
615505
 MK 85152

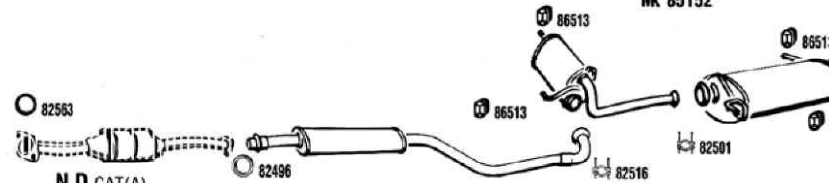

7317185

PE60525 **CAT**

605
SLi - SRi
 2.0i 16v
07/94-12/00
 1998 cc - 135 HP - 99 kW
 Mot/Eng: XU10J4R
 Type/Typ: 6BRFV2-6BRFV4-6BRFV9
 TSN: 761

1705 J6
9220386CAT
 MK 18473

1717-45
615232

1726-E7
615504

1726-E8
615233

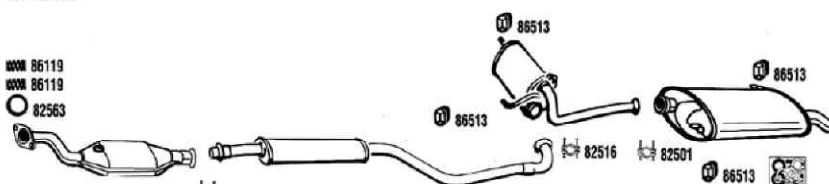

7317185

PE60530 **CAT**

● En desarrollo

Los nombres y números de primer equipo se utilizan solamente como referencia

IMPORTANTE:

Al pedir sistemas de escape, rogamos completen la referencia comenzando por 'MFO.' (ejemplo: 381394 → MFO.381394)
 Pour commander echappement, nous vous prions de compléter la référence en commençant par MFO..
 When ordering exhaust, please complete the reference by beginning with MFO..

ESCAPE / ECHAPPEMENT / EXHAUST

Fonos

Peugeot

MOTOR / MOTEUR / ENGINE

1704-87 N.D.	1721-99 N.D.CAT	815420	1728-85 615508	1728-51 615509
-----------------	--------------------	---------------	--------------------------	--------------------------

N.D. 1704-83
N.D. 1709-05

λ ¹ 87854	87910	87999x2	λ ² 87854	87912
----------------------	-------	---------	----------------------	-------

7315510

605 SR-SV
3.0i V6 12v
10/89-98
2975 cc - 167 HP - 123 kW
Mot/Eng: ZPJ
Type/Typ: 6BSFZ2 - TSN: 640
λ¹-10/89->06/94
λ²-07/94->00/98

PE60513 **CAT**

N.D.	N.D.CAT	1728-86 6718041	1728-51 615509
------	---------	---------------------------	--------------------------

N.D. N.D.CAT

λ ¹ 87854	87910	87999x2	λ ² 87854	87912
----------------------	-------	---------	----------------------	-------

7318042

605 SV-SVE
3.0i V6 24v
10/89-98
2975 cc - 200 HP - 147 kW
Mot/Eng: ZPJ4 (Multi Point Inj.)
Type/Typ: 6BSKZ2 - TSN: 641
λ¹-10/89->06/94
λ²-07/94->00/98

PE60522 **CAT**

1705-56 6815970	1726-E7 615504	1726-46 615505 MK 85152
---------------------------	--------------------------	--------------------------------------

ww 82598
ww 82598

82563

7315972

605 SLD-SRD
2.1 Diesel
03/90-06/94
2138 cc - 83 HP - 61 kW
Mot/Eng: XUD11A (PYZ)
Type/Typ: 6BP9A2-6BPJZ2-6BPYZ2

PE60515

1705-28 N.D.	1728-90 615512	1728-87 615513	1726-54 615514
-----------------	--------------------------	--------------------------	--------------------------

ww 86119
ww 86119

82563
ww 86119

7318045

605 SLDT-SRDT-SVDT
2.1 TD 12v
10/89-95
2088 cc - 110 HP - 80 kW
Mot/Eng: XUD11ATE
Type/Typ: 6BP8A2/A4/B2/B4-6BPHZ2/4
TSN: 645

PE60523

1705-28 N.D.	1731-19 92 20669 CAT	1731-20 52 19577	1717-23 615578	1726-54 615514
-----------------	--------------------------------	----------------------------	--------------------------	--------------------------

ww 86119

82563
ww 86119

86219

7318045

605 SLDT-SRDT-SVDT
2.1 TD 8v
02/92-98
2088 cc - 110 HP - 80 kW
Mot/Eng: XUD11ATE
Type/Typ: 6BP8A2/A4/B2/B4-6BPHZ2/4
TSN: 645

PE60528 **CAT**

0341-84 N.D.	1705-A3 615669	1731-37 615231	1717-50 615230	1726-G3 615229
-----------------	--------------------------	--------------------------	--------------------------	--------------------------

86219

86219

86562

81835

81835

7321073

605 SRDT
2.5 TD
07/94-98
2446 cc - 130 HP - 96 kW
Mot/Eng: DK5ATE
Type/Typ: 6BTHY2

PE60532

Los nombres y números de primer equipo se utilizan solamente como referencia

● En desarrollo

IMPORTANTE:

Al pedir sistemas de escape, rogamos completen la referencia comenzando por 'MFO.' (ejemplo: 381394 → MFO.381394)
 Pour commander echappement, nous vous prions de compléter la référence en commençant par MFO..
 When ordering exhaust, please complete the reference by beginning with MFO..

Peugeot

Fonos

605
SRDT
2.5 TD
07/94-98
2446 cc - 130 HP - 96 kW
Mot/Eng: DK5ATE
Type/Typ: 6BTHY2

1705-A4 N.D. 1731-35 N.D.CAT 1731-37 615231 1717-50 615230 1726-G3 615229

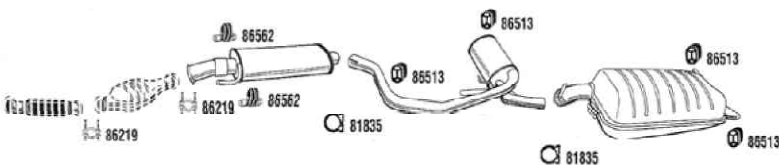

PE60533 CAT

N.D.
0341-84



607
2.0
05/00-
1997 cc - 138 HP - 100 kW
Mot/Eng: EW10J4
Type/Typ: 9D

1705RQ N.D.CAT 1717W3 N.D. 1726RZ 615619

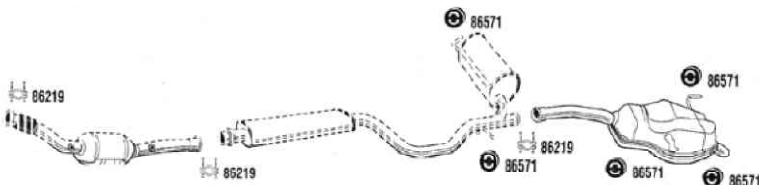

PE60703 CAT

607
2.2
05/00-
2230 cc - 158 HP - 116 kW
Mot/Eng: EW12J4
Type/Typ: 9D

1705RV 9220697CAT 1717W3 N.D. 1726RZ 615619

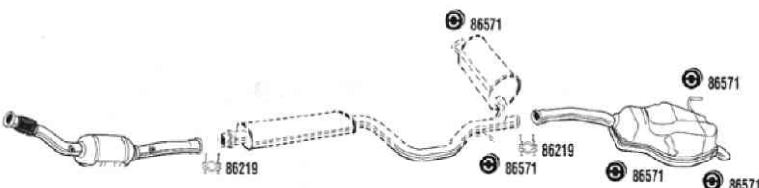

PE60704 CAT

607
3.0
05/00-
2946 cc - 210 HP - 155 kW
Mot/Eng: ESJ4S
(A) - 11/02 - (B) 11/02-
Type/Typ: 9D

1705 GA N.D. 1731J9 9220698CAT 1717W2 N.D. 1726FS N.D.(A)

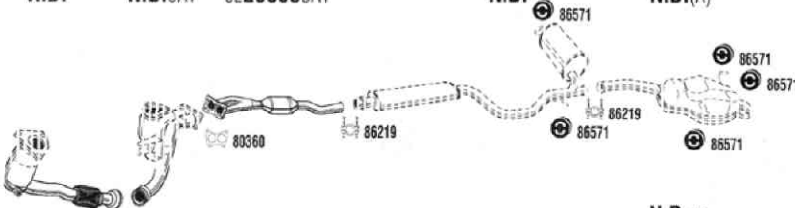

PE60706 CAT

607
2.0 HDi
05/00-
1997 cc - 109 HP - 80 kW
Mot/Eng: DW10ATED
W/PARTICLE FILTER
(A) particle filter
Type/Typ: 9DR

1705 LL N.D. 1731 S1 N.D.CAT 1731 S2 N.D.CAT(A) 1717H2 6607595 1726RX 615275 MK 85961



PE60701 CAT

607
2.0 HDi
05/00-
1997 cc - 109 HP - 80 kW
Mot/Eng: DW10ATED
W/O PARTICLE FILTER
Type/Typ: 9DR

1705GK N.D. 1705GL N.D.CAT 1726RX 615275 MK 85961



PE60705 CAT

● En desarrollo

Los nombres y números de primer equipo se utilizan solamente como referencia

IMPORTANTE:

Al pedir sistemas de escape, rogamos completen la referencia comenzando por 'MFO.' (ejemplo: 381394 → MFO.381394)
Pour commander echappement, nous vous prions de compléter la référence en commençant par MFO..
When ordering exhaust, please complete the reference by beginning with MFO..

ESCAPE / ECHAPPEMENT / EXHAUST

Fonos

Peugeot

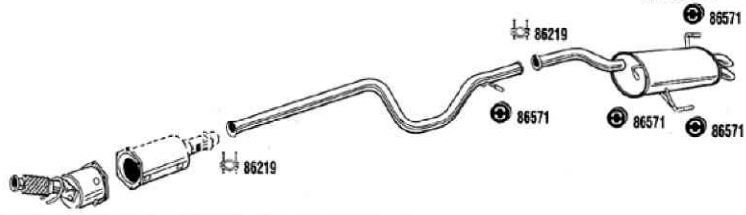
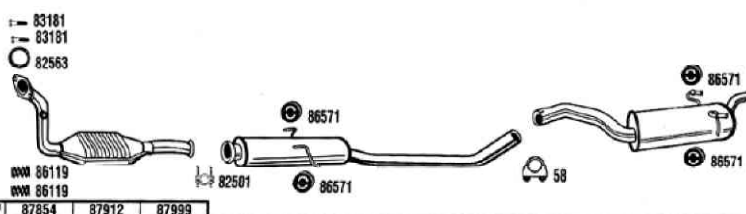
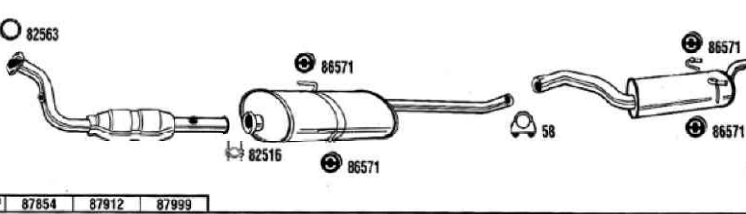
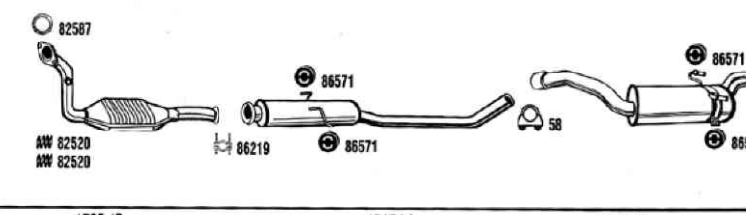
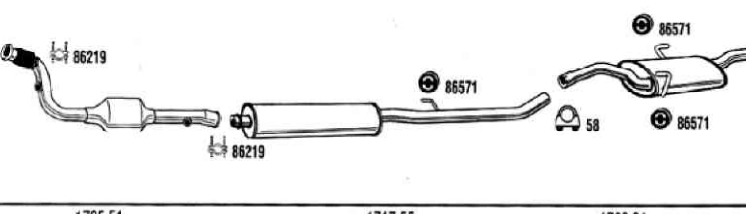
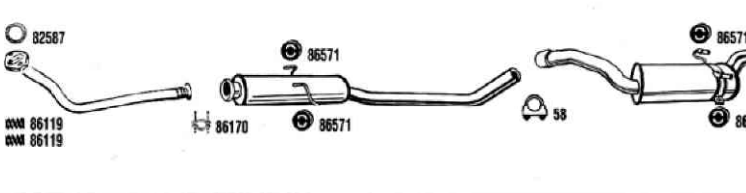
<p>1731 W3 N.D.CAT</p> <p>1731 K5 N.D.CAT(A)</p> <p>1717H2 6607595</p> <p>1726RX 615275 MK 85961</p> 	<p>607</p> <p>2.2 HDi 12/99-</p> <p>2179 cc - 133 HP - 98 kW Mot/Eng: DW12TED4 W/PARTICLE FILTER (A) partic filter Type/Typ: 9D4</p> <p>PE60702 CAT</p>
<p>1705 W2 9221581CAT MK 21826</p> <p>1717 55 613193 MK 85508</p> <p>1726 E5 613192 MK 85509</p> 	<p>806</p> <p>2.0 06/94-08/02</p> <p>1998 cc - 121 HP - 89 kW Mot/Eng: RFU (XU10J2) Type/Typ: 221</p> <p>PEW80620 CAT</p>
<p>1705 AL 9320508CAT</p> <p>1717C5 610609 MK 85571</p> <p>1726 Z6 610607 MK 85509</p> 	<p>806</p> <p>2.0 16v 05/98-09/00</p> <p>1998 cc - 132 HP - 97 kW Mot/Eng: RFV (XU10J4F) Type/Typ: 221</p> <p>PEW80621 CAT</p>
<p>1705 H5 9221582CAT</p> <p>171733 613190 MK 85571</p> <p>1726 91 613191 MK 85509</p> 	<p>806</p> <p>2.0 Turbo 06/94-08/02</p> <p>1998 cc - 147 HP - 108 kW Mot/Eng: RGX (XU10J2TE) Type/Typ: 221</p> <p>PEW80623 CAT</p>
<p>1705 JR 9320593CAT</p> <p>1717 L0 613288 MK 85880</p> <p>1726 HF 610579 MK 85509</p> 	<p>806</p> <p>2.0 16v 09/00-08/02</p> <p>1997 cc - 136 HP - 100 kW Mot/Eng: RFN (EW10J4) Type/Typ: 221</p> <p>PEW80622 CAT</p>
<p>1705 E1 6221583</p> <p>1717 55 613193 MK 85508</p> <p>1726 91 613191 MK 85509</p> 	<p>806</p> <p>1.9 TD 05/97-08/02</p> <p>1905 cc - 92 HP - 68 kW Mot/Eng: DHY (XUD9TE) Type/Typ: 221</p> <p>PEW80625</p>

Los nombres y números de primer equipo se utilizan solamente como referencia

● En desarrollo

IMPORTANTE:

Al pedir sistemas de escape, rogamos completen la referencia comenzando por 'MFO.' (ejemplo: 381394 → MFO.381394)

Pour commander echappement, nous vous prions de compléter la référence en commençant par MFO..

When ordering exhaust, please complete the reference by beginning with MFO..

Peugeot

Fonos

MOTOR / MOTEUR / ENGINE

806
1.9 TD
07/95-08/02
1905 cc - 90 HP - 66 kW
Mot/Eng: DHX (XUD9TE)
Type/Typ: 221

PEW80624 **CAT**

1705 R7
92**21584**CAT

1717 55
613193
MK 85508

1726 91
613191
MK 85509

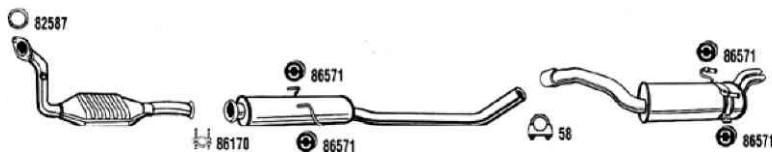

806
2.0 HDi
08/99-05/00
1997 cc - 109 HP - 80 kW
Mot/Eng: RHZ (DW10ATED)
Type/Typ: 221

PEW80626 **CAT**

1705 JJ
92**20546**CAT
MK 21827

1717 55
613193
MK 85508

1726 91
613191
MK 85509

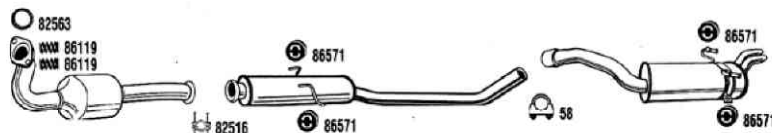

806
2.0 HDi
05/00-08/02
1997 cc - 109 HP - 80 kW
Mot/Eng: RHW,RHZ (DW10ATED)
Type/Typ: 221

PEW80627 **CAT**

1705 JJ
92**20546**CAT
MK 21827

1717 J6
610576

1726 HC
610606
MK 85509

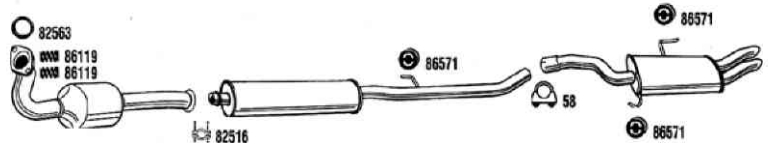

806
2.1 TD 12v
06/96-08/99
2088 cc - 109 HP - 80 kW
Mot/Eng: P8C (XUD11BTE)
Type/Typ: 221

PEW80628 **CAT**

1705 N1
92**21585**CAT
MK 21827

1717 55
613193
MK 85508

1726 91
613191
MK 85509

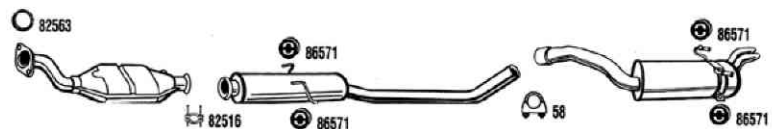

807
2.0 HDi
03/02-
1997 cc - 109 HP - 80 kW
Mot/Eng: RHM,RHT (DW10ATED4)
Type/Typ: E

PEW80705 **CAT**

1731X7
N.D.CAT

1731X9
N.D.CAT

1717R2
64**08228**

1726LW
● **610675**

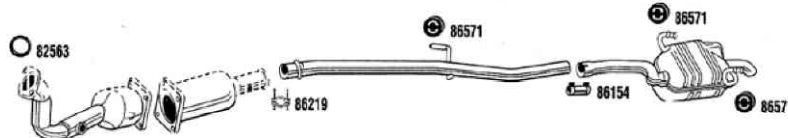

807
2.0 HDi
03/03-
1997 cc - 109 HP - 80 kW
Mot/Eng: RHW (DW10ATED4)
Type/Typ: E

PEW80706 **CAT**

1705 NIW
92**20615**CAT

1717R1
N.D.

1726NS
N.D.

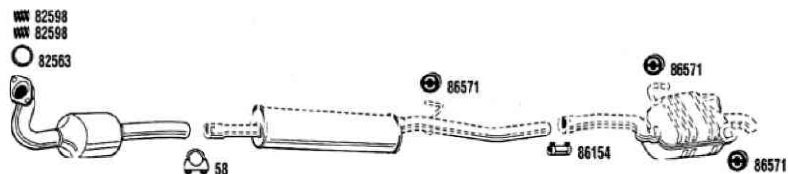

● En desarrollo

Los nombres y números de primer equipo se utilizan solamente como referencia

IMPORTANTE:

Al pedir sistemas de escape, rogamos completen la referencia comenzando por 'MFO.' (ejemplo: 381394 → MFO.381394)
Pour commander echappement, nous vous prions de compléter la référence en commençant par MFO..
When ordering exhaust, please complete the reference by beginning with MFO..

ESCAPE / ECHAPPEMENT / EXHAUST

Fonos

Peugeot

1731X8
N.D.CAT

1731X9
N.D.CAT

1717R2
6408228

1726LY
● 610849

807
2.2 HDi
06/02-
2179 cc - 128 HP - 94 kW
Mot/Eng: 4HX (DW12TED4)
Type/Typ: E
W/ Particle Filter

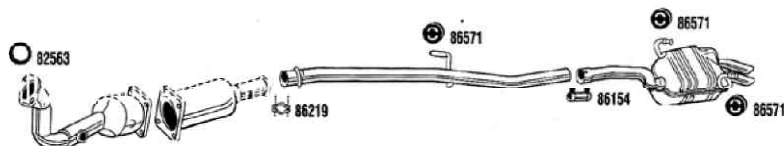

PEW80707 **CAT**



MOTOR / MOTEUR / ENGINE

Los nombres y números de primer equipo se utilizan solamente como referencia

● En desarrollo

IMPORTANTE:

Al pedir sistemas de escape, rogamos completen la referencia comenzando por 'MFO.' (ejemplo: 381394 → MFO.381394)

Pour commander echappement, nous vous prions de compléter la référence en commençant par MFO..

When ordering exhaust, please complete the reference by beginning with MFO..

ESCAPE / ECHAPPEMENT / EXHAUST

Fonos

OE No.	Ref.	OE No.	Ref.	OE No.	Ref.
Citroën		Citroën		Citroën	
170291	31348	1705F2	613588	1705NY	20615
170484	20387	1705F3	613588	1705P2	613865
170519	07174	1705F5	20296	1705P3	613865
170520	07172	1705F6	20755	1705P4	20309
170544	04064	1705FA	20217	1705P4	07581
170548	19790	1705FH	20652	1705P5	20309
170548	313110	1705FK	20297	1705P7	613588
170552	20296	1705FL	20297	1705P8	613588
170557	613126	1705FQ	20578	1705PP	20673
170558	313136	1705FR	20578	1705PS	613842
170565	07172	1705FS	20590	1705QL	20580
170566	07176	1705FV	20579	1705QL	20721
170572	19286	1705FW	20579	1705QQ	20590
170573	19283	1705G1	20317	1705QZ	20640
170575	20443	1705G2	20317	1705R7	21584
170577	19286	1705GQ	01486	1705R8	21584
170578	19283	1705GS	17131	1705RA	20640
170580	20443	1705GX	20458	1705RG	20644
170584	19790	1705GY	20458	1705RH	20644
170587	21582	1705H2	20317	1705S2	19790
170588	21582	1705H3	21581	1705SR	20580
170592	05322	1705H4	21581	1705SR	20721
170593	05322	1705H5	21582	1705SV	20730
1705A1	20386	1705H6	21582	1705T4	20311
1705A5	21581	1705HA	20314	1705T4	07579
1705A6	21581	1705HC	20314	1705T5	20317
1705A8	21807	1705HV	06549	1705T6	19790
1705AC	20316	1705J5	20097	1705T7	21808
1705AC	07581	1705J6	20386	1705T8	20297
1705AE	20316	1705J9	20097	1705T9	19790
1705AE	07581	1705JE	20580	1705V0	20296
1705AF	20345	1705JE	20721	1705V5	21586
1705AG	20345	1705JF	20610	1705V6	21586
1705AL	20508	1705JK	20316	1705V8	21808
1705AN	20508	1705JK	07581	1705V9	21812
1705AP	20296	1705JL	20316	1705W0	21810
1705AS	20314	1705JL	07581	1705W2	21581
1705C0	21811	1705JN	20645	1705W3	21581
1705C2	20217	1705JP	20546	1705W4	21810
1705C5	20386	1705JQ	20546	1705W7	613790
1705C7	20386	1705JR	20593	1705X3	313110
1705C9	21811	1705JS	20593	1705X4	04064
1705CC	20316	1705K0	20117	1705X6	20297
1705CC	07581	1705K1	20474	1705X9	21812
1705CE	20316	1705K2	20317	1705Y0	20401
1705CE	07581	1705K3	21807	1705Y1	20591
1705CK	20673	1705K4	04064	1705Y4	07172
1705CL	20673	1705K6	07174	1705Y5	07172
1705CS	20677	1705K7	07172	1705Y8	19790
1705D0	21807	1705K8	07176	1705Y9	21809
1705E1	21583	1705KJ	613756	1705Z0	21809
1705E2	21583	1705KV	20589	1705Z5	20317
1705E3	21584	1705KZ	20578	1705Z9	20315
1705E4	21584	1705L6	19790	1705ZN	20590
1705E7	20311	1705L8	20388	1705ZR	07967
1705E7	07579	1705L9	20388	1705ZS	20693
1705EQ	20546	1705LW	613756	170633	18330
1705ER	20546	1705N1	21585	170642	20245
1705EY	20468	1705N2	21585	170646	20296
1705EZ	20589	1705N8	20468	170649	20297
1705F0	21586	1705NF	20610	170673	20640
1705F1	21586	1705NG	20610	1706A7	20693
		1705NH	20657	171732	613190
		1705NJ	20644	171733	613190
		1705NS	610778	171738	613113
		1705NT	20653	171739	613546
		1705NW	20615	171743	613193

Los nombres y números de primer equipo se utilizan solamente como referencia

IMPORTANTE:

Al pedir sistemas de escape, rogamos completen la referencia comenzando por 'MFO.' (ejemplo: 381394 → MFO.381394)

Pour commander echappement, nous vous prions de compléter la référence en commençant par MFO..

When ordering exhaust, please complete the reference by beginning with MFO..

ESCAPE / ECHAPPEMENT / EXHAUST

Fonos

MOTOR / MOTEUR / ENGINE

OE No.	Ref.	OE No.	Ref.	OE No.	Ref.	OE No.	Ref.
Citroën		Citroën		Citroën		Citroën	
171744	613193	1717N0	613498	1726GN	615393	1726S6	613818
171746	613302	1717N1	613424	1726GW	613385	1726S7	613818
171747	613196	1717N2	613424	1726GX	613818	1726S8	613932
171751	613212	1717N7	613403	1726H1	613191	1726T7	613819
171752	613187	1717P2	613498	1726H2	615726	1726T9	613197
171753	613187	1717P3	613498	1726H3	613114	1726TV	613843
171754	613193	1717P5	613535	1726H4	613218	1726TX	613178
171755	613193	1717P6	615215	1726H5	613219	1726TY	613844
171756	613473	1717Q5	613593	1726H6	613189	1726TZ	615213
171759	613215	1717Q6	613761	1726H7	613213	1726V1	613197
171760	613216	1717Q7	610779	1726HH	613184	1726V5	613592
171764	61362	1717R2	08228	1726HJ	613183	1726VA	615210
171765	613160	1717R6	06848	1726HL	613185	1726VZ	615804
171766	613165	1717R7	06849	1726HN	613427	1726W6	613219
171768	615129	1717R8	06850	1726HS	613755	1726W8	613993
171770	613165	1717R9	613307	1726HT	610606	1726WA	615211
171774	613866	1717S0	613307	1726HV	615793	1726WS	615211
171775	613866	1717S1	613310	1726HW	610579	1726X3	613821
171779	615129	1717T0	07150	1726HX	613791	1726X4	613818
171788	613175	1717T2	07191	1726J0	613137	1726X5	613822
171790	21859	1717V2	08214	1726J1	613217	1726X6	613930
171792	21858	1717V7	07641	1726J6	613592	1726XF	613716
171796	21859	1717V8	613634	1726JJ	613427	1726YK	613635
171797	613867	1717V9	613637	1726JK	613221	1726Z4	613587
171798	613931	1717W7	615802	1726JN	613423	1726Z5	613587
171799	613186	1717Z3	08555	1726JT	613423	1726Z7	610607
1717A1	613868	1717Z9	08227	1726K6	613363	1726Z8	613404
1717A3	613160	172128	613509	1726K7	61346	172897	615129
1717A4	613175	172231	1379	1726K9	613714	173104	815420
1717AG	07642	172274	631349	1726KC	613153	173113	19173
1717AJ	613182	172291	631349	1726KJ	613485	173121	20096
1717AK	615212	172681	613131	1726KZ	613993	173122	20096
1717C3	613187	172682	613137	1726L0	613153	173125	20154
1717C4	613187	172684	613238	1726L1	613153	173140	20154
1717C5	610609	172687	613150	1726L2	613166	173141	20474
1717C6	610609	172689	613536	1726L3	613153	173143	20474
1717C9	613867	172692	613191	1726L5	615726	173144	20315
1717CS	07642	172698	613194	1726LC	613423	173147	20459
1717E7	03472	172699	613194	1726LF	613423	173148	20753
1717F2	613387	1726A0	613194	1726LH	613184	173151	19789
1717F5	610604	1726A1	613313	1726LX	610675	173152	19172
1717F6	610604	1726A6	613197	1726LZ	610849	173153RP	08138
1717F7	610605	1726A7	613197	1726N4	613218	173154	20755
1717F9	613193	1726A8	613197	1726N6	613993	173156	19172
1717G0	613193	1726A9	613197	1726N8	613993	173158	19172
1717G1	613179	1726AF	613188	1726NC	613755	173159	19172
1717G2	613180	1726AH	613993	1726NF	615793	173160	19173
1717G3	613181	1726AJ	613818	1726NH	613791	173161	20154
1717G6	613544	1726AK	613385	1726NQ	613289	173163	20154
1717H0	615394	1726E6	613192	1726NR	613304	173164	20543
1717H1	615394	1726EN	613844	1726NT	613306	173165	19172
1717J6	610576	1726EP	613178	1726NV	613308	173166	20154
1717J7	613760	1726EQ	613843	1726NW	613309	173168	20096
1717K0	613288	1726F0	613320	1726P0	613191	173169	20096
1717K1	06498	1726F1	19547	1726P6	613536	173178	19172
1717K2	613403	1726F2	19547	1726R7	613105	173187	20315
1717K3	613403	1726F3	613195	1726R8	613148	173188	20242
1717K4	613754	1726F4	613315	1726R9	613114	173190	19172
1717K5	613399	1726F5	613315	1726RL	613592	173191	19172
1717K6	613398	1726FG	613930	1726RN	613716	173192	19173
1717K7	613182	1726FZ	613404	1726RP	613768	173193	20154
1717K8	610576	1726G7	613587	1726RT	613716	173195	20255
1717K9	613760	1726G9	613587	1726RV	613699	173196	20245
1717L0	613288	1726GA	613821	1726RW	613635	173197	19173
1717L7	07150	1726GE	613822	1726S0	615726	173198	20256
1717L8	07150	1726GG	613385	1726S1	613114	173199	20323
1717L9	613498	1726GK	613226	1726S3	613188	1731A2	20256

Los nombres y números de primer equipo se utilizan solamente como referencia

IMPORTANTE:

Al pedir sistemas de escape, rogamos completen la referencia comenzando por 'MFO.' (ejemplo: 381394 → MFO.381394)

Pour commander echappement, nous vous prions de compléter la référence en commençant par MFO..

When ordering exhaust, please complete the reference by beginning with MFO..

OE No.	Ref.	OE No.	Ref.	OE No.	Ref.	OE No.	Ref.
Citroën		Citroën		Citroën		Citroën	
1731A3.....	20543	5429110R.....	613206	75527066.....	1355	95599280.....	61346
1731C2.....	20255	5429112M.....	613242	75527203.....	613206	95600360.....	31384
1731C7.....	20584	5429119N.....	01025	7579129.....	613225	95600364.....	61385
1731C8.....	20584	5429123G.....	31324	7579139.....	613226	95600365.....	61386
1731C9.....	20242	5429126.....	31323	76491877.....	01164	95600643.....	1368
1731E0.....	20256	5429126P.....	31323	7710074.....	613225	95600643.....	61363
1731E1.....	20216	5429128.....	31323	7910030845.....	631350	95602665.....	61382
1731E2.....	20216	5429131U.....	01022	7910030920.....	31348	95602667.....	61383
1731E3.....	19173	5429135.....	613205	7910030921.....	631349	95604837.....	31359
1731E8.....	19173	5429135M.....	613205	7910032651.....	1379	95610048.....	01164
1731E9.....	19172	5429138V.....	01078	7910032652.....	631232	95610049.....	01164
1731F0.....	19172	5429142.....	613204	90601.....	03498	95610184.....	61391
1731F6.....	20459	5431261W.....	1330	90602.....	03498	95610186.....	31392
1731F9.....	19173	5431261W.....	1330-R	91500211.....	31348	95610187.....	61393
1731FL.....	20656	5431265P.....	31329	91500384.....	31348	95610188.....	61394
1731G0.....	19173	5433458.....	01104	91502461.....	31348	95610365.....	01221
1731G8.....	20255	5451294V.....	1341-F	9150246180.....	31348	95631603.....	61388
1731G9.....	20255	5451571.....	631339	91502462.....	1378	95631605.....	31387
1731GP.....	20644	5459784.....	31329	9150246280.....	1378	95631605.....	31390
1731GQ.....	20644	5465334E.....	613206	91502465.....	631349	95631697.....	31389
1731H0.....	20245	5465335R.....	631332	91509520.....	613509	95632630.....	61394
1731H1.....	20245	5472851.....	1340	9150995880.....	631232	95632631.....	613697
1731H3.....	20255	5484445.....	31374	91510622.....	01475	95632640.....	61391
1731H4.....	20245	5490335.....	01068	91519172.....	631349	95633748.....	12273
1731H5.....	19172	5490413.....	613201	94560389.....	815420	95634349.....	31392
1731H7.....	20336	5490494.....	1341-F	95039219.....	31366	95634351.....	61393
1731HR.....	20338	5490566.....	1330	95492391.....	1330	95635129.....	14035
1731J0.....	20577	5490566.....	1330-R	95492391.....	1330-R	95635692.....	31367
1731J2.....	20671	5490646.....	01164	95492976.....	1330	95636428.....	14220
1731J8.....	20336	5490647.....	631339	95492976.....	1330-R	95638423.....	31304
1731K3.....	20336	5490647W.....	631339	95492977.....	1330	95638425.....	61305
1731K9.....	20255	5490713N.....	631339	95492977.....	1330-R	95638426.....	61306
1731L0.....	19172	5490718.....	613206	95493052.....	01132	95639056.....	18330
1731L8.....	20649	54907474.....	01164	95493053.....	01132	95639837.....	15427
1731N1.....	20576	5490748.....	631339	95493055.....	01068	95640233.....	13699
1731N2.....	19173	5490750.....	631339	95495446.....	631332	95640234.....	61394
1731N8.....	20616	5490760.....	631339	95537118.....	1328	95640238.....	613697
1731N8.....	07953	5490919.....	631339	95538685.....	08380	95640716.....	14224
1731N9.....	20627	5490971.....	631377	95538707.....	08379	95650909.....	61393
1731P2.....	20627	5491183.....	631339	95543643.....	631339	95650909.....	61394
1731P3.....	20674	5491391.....	1330	95543644.....	631339	95653975.....	613406
1731T9.....	20616	5491391.....	1330-R	95543645.....	631339	95653976.....	613202
1731T9.....	07953	5503289.....	31354	95543646.....	01164	95653988.....	01104
1731V3.....	20654	5506413.....	1326-D	95543647.....	01164	95653989.....	01105
1731V7.....	20616	5634129.....	1340	95549728.....	613261	95653990.....	01107
1731V7.....	07953	5963507.....	01492	95550154.....	1313	95654014.....	613421
1731V8.....	20573	75490713.....	631339	95550167.....	1314	95654015.....	613422
1731W0.....	20574	75491612.....	631332	95551528.....	1314	95654018.....	17120
1731W1.....	20575	75491622.....	01050	95572140.....	01211	95654019.....	613123
1731W2.....	20656	75491875.....	01164	95572141.....	01200	95654020.....	613425
1731Y1.....	20655	75492020.....	01050	95572142.....	01200	95661783.....	613199
1731Z6.....	20656	75492264.....	631332	95576334.....	61363	95666769.....	613422
173212B.....	04068	75492528.....	01164	95576336.....	61362	95666770.....	613123
173212S.....	98751	75492528.....	613263	95585992.....	61337	95666771.....	613199
179291.....	31348	75492530.....	631339	95586071.....	613202	96001963.....	61386
1827918.....	98756	75492604.....	1341-F	95588510.....	31369	96003913.....	31371
5423644.....	613204	75510643.....	31323	95588568.....	31360	96012198.....	13694
5429049S.....	01032	75510645.....	31324	95588569.....	31361	96012771.....	31397
5429093F.....	31321	75510647.....	31323	95588570.....	61362	96012772.....	61398
5429094S.....	31321	75510897.....	1375	95588571.....	61363	96012916.....	13694
5429095.....	31323	75510952.....	631356	95590439.....	31370	96012918.....	13695
5429095C.....	31323	75510953.....	631357	95595830.....	31347	96014789.....	18330
5429096.....	631332	75511211.....	31325	95596745.....	01211	96016570.....	19139
5429096N.....	631332	75517968.....	631376	95596745.....	12276	96018813.....	613200
5429098K.....	613316	75518013.....	31323	95596746.....	01211	96021036.....	61305
5429101T.....	01002	75525421.....	1326-D		+12276	96021037.....	61306
5429106X.....	01004	75525428.....	31323	95598991.....	12275	96021645.....	613106

Los nombres y números de primer equipo se utilizan solamente como referencia

IMPORTANTE:

Al pedir sistemas de escape, rogamos completen la referencia comenzando por 'MFO.' (ejemplo: 381394 → MFO.381394)

Pour commander echappement, nous vous prions de compléter la référence en commençant par MFO..

When ordering exhaust, please complete the reference by beginning with MFO..

ESCAPE / ECHAPPEMENT / EXHAUST



OE No.	Ref.	OE No.	Ref.	OE No.	Ref.
				Citroën	
				Citroën	
				Peugeot	
96021651	613122	A1832B	01002	170129	01281
96021664	613107	AM18210	613206	170158	01318
96021679	613108	AM1821D	613206	170159	01321
96041772	313110	AM1821E	613201	170171	01256
96041777	19790	AM1821E	613206	170173	01256
96041778	613104	AM182293A	31323	170175	1501
96041781	613118	AM1824B	01025	170177	01256
96041783	613149	AM1824C	01032	170178	01256
96041785	613100	AM1824C	31321	170180	01427
96041786	19789	AM18293A	01022	170192	01237
96041787	613113	AM18293B	01022	170197	01326
96041788	613117	AM1832A	613316	170198	01326
96041796	613101	AY1820	631332	170203	01322
96041798	613101	AY1824	01111	170204	01357
96041800	613101	AY1824	31321	170239	01237
96043519	17131	AY18293	31323	170240	01365
96045750	20387	AY18293A	31323	170254	01394
96045753	613556	AYB1821	613242	170262	01394
96045756	613238	AZ182293A	31323	170263	31348
96046471	61363	AZ1831A	01004	170265	01443
96046482	61346	AZU18293	31324		
96048418	61394	DS1824	01230		
96048419	613697	DV1822	01076		
96054786	31389	DV1823	01076		
96064421	61388	DX1820	613204		
96064537	13699	DX1823	01078		
96065832	15427	DX182905A	01076		
96067240	61388	DX182905B	01229		
96067243	61306	DX1830	613205		
96067245	61306	GX0411601A	1330		
96068951	17118	GX0411601A	1330-R		
96070794	613105	GX0411601B	1330		
96076275	31359	GX0411601B	1330-R		
96080654	19790	GX0411602A	1330		
96081984	20312	GX0411602A	1330-R		
96087628	613102	GX0414003A	1327		
96092271	20295	GX0414103A	1326-D		
96092272	17534	GX0414104A	1326-D		
96092273	17531	GX0415201A	31329		
96092280	17535	GX0415201B	31329		
96097865	17168	GX0524601A	1330		
96106848	20097	GX0524601A	1330-R		
96106851	613130	HY1824	01111		
96106854	20117	ZA95004118L	613202		
96106856	613133	ZF05923549	610889		
96119136	613198	ZF05925058	01487		
96119137	613320	ZF05934206	01486		
96126689	613546	ZF05956499	613490		
96131133	613108	ZF05963507	01492		
96134334	20635	ZF07579129	613225		
96134337	613175	ZF07579139	613226		
96134901	20315	ZF07654355	01492		
96134902	613554	ZF07654355	610889		
96141743	20117	ZF07654356	610889		
96142630	613148	ZF07654358	610888		
96144012	18330	ZF07710074	613225		
96145069	19789				
96145070	613100				
96145084	613114				
96145891	19789				
96145941	21807				
96146819	613101				
96147572	613101				
96151664	613150				
96164115	613131				
96164371	613134				
9750817980	613913				

Los nombres y números de primer equipo se utilizan solamente como referencia

IMPORTANTE:

Al pedir sistemas de escape, rogamos completen la referencia comenzando por 'MFO.' (ejemplo: 381394 → MFO.381394)

Pour commander echappement, nous vous prions de compléter la référence en commençant par MFO..

When ordering exhaust, please complete the reference by beginning with MFO..

ESCAPE / ECHAPPEMENT / EXHAUST

Fonos

MOTOR / MOTEUR / ENGINE

OE No.	Ref.	OE No.	Ref.	OE No.	Ref.	OE No.	Ref.
Peugeot		Peugeot		Peugeot		Peugeot	
170268	1501	170460	19771	1705AW	20571	1705HQ	07768
170270	01427	170462	18356	1705AX	20587	1705HR	20592
170271	01326	170474	13222	1705C0	21811	1705HS	20592
170272	01326	170480	15489	1705C7	20386	1705HT	20548
170280	31518	170482	815503	1705CA	02640	1705J0	20297
170287	01394	170484	20387	1705CC	20316	1705J1	615206
170288	1505	170488	07180	1705CC	07581	1705J2	21743
170290	1378	170490	19771	1705CE	20316	1705J2	08299
170291	31348	170490S	98754	1705CE	07581	1705J3	21605
170306	01486	170491	61549	1705CF	615206	1705J4	21605
170307	01487	170492	18356	1705CJ	21743	1705J5	21605
170308	08565	170495	815501	1705CJRP	07578	1705J6	20386
170309	01496	170497	816294	1705CJ	08299	1705JH	20353
170310	01475	170498	13222	1705CZ	02716	1705JJ	20546
170311	01484	170499	15497	1705D0	21807	1705JK	20316
170312	01481	170503	15970	1705E1	21583	1705JK	07581
170315	08564	170505	15958	1705E2	21583	1705JL	20316
170316	01365	170506	615961	1705E3	21584	1705JL	07581
170318	01510	170507	31596	1705E4	21584	1705JN	20645
170320	01443	170509	20668	1705EC	20352	1705JP	20546
170321	31518	170510	07180	1705EF	20353	1705JQ	20546
170322	08561	170513	816297	1705EG	20353	1705JR	20593
170323	08563	170516	315123	1705EGRP	07583	1705JW	20352
170331	01501	170518	17168	1705EN	20548	1705JY	20648
170334	08552	170519	07174	1705EP	20354	1705K3	21807
170341	31523	170520	07172	1705EP	08234	1705KA	20678
170344	31527	170522	17176	1705EQ	20546	1705KJ	613756
170352	08530	170531	20126	1705ER	20546	1705KS	20354
170353	08530	170532	20646	1705ET	20299	1705KT	20354
170357	08531	170537	31371	1705ET	07580	1705KV	20589
170358	61534	170544	04064	1705EV	21597	1705L6	19790
170362	09407	170545	21807	1705EZ	20589	1705L7	21581
170364	09410	170548	313110	1705F0	21586	1705L8	20388
170376	12690	170549	08300	1705F1	21586	1705LA	20344
170382	12492	170551	20297	1705F2	613588	1705LA	07777
170388	31530	170552	20296	1705F5	20296	1705LH	06434
170392	812295	170556	15970	1705FC	20548	1705LW	613756
170394	31540	170560	615183	1705FH	20652	1705LY	20352
170395	13628	170561	615185	1705FL	20297	1705N1	21585
170398	31538	170565	07172	1705FN	20589	1705N4	21598
170407	12480	170566	07176	1705FX	20592	1705N5	21597
170408	18356	170572	19286		+615526	1705N7	20588
170418	61561	170573	19283	1705FY	20592	1705NH	20657
170420	31536	170575	20443		+615526	1705NK	20353
170422	13217	170578	19283	1705G0	20646	1705NQ	20344
170423	13222	170580	20443	1705G4	20310	1705NQ	07777
170426	13225	170582	615190	1705G4RP	07186	1705NR	20547
170427	17155	170587	21582	1705G5	20310	1705NR	08235
170428	31596	170588	21582	1705G5RP	07187	1705NS	610778
170430	615961	170593	05322	1705G6	20310	1705NT	20653
170433	19771	1705A1	20386	1705G7	21597	1705NW	20615
170435	31545	1705A3	615669	1705G8	21597	1705NY	20615
170438	31553	1705A5	21581	1705GG	20697	1705P0	20715
170439	13221	1705A6	21581	1705GW	20734	1705P1	21807
170440	13216	1705A8	21807	1705GZ	20354	1705P2	613865
170441	13221	1705AA	20572	1705GZ	08234	1705P4	20309
170442	13216	1705AA	07767	1705H3	21581	1705P4	07581
170443	17151	1705AC	20316	1705H4	21581	1705P7	613588
170449	14224	1705AC	07581	1705H5	21582	1705P8	613588
170450	14228	1705AE	20316	1705H6	21582	1705PH	20354
170451	18356	1705AE	07581	1705HF	07162	1705PJ	20354
170452	13681	1705AF	20345	1705HG	07162	1705PS	613842
170453	14220	1705AG	20345	1705HH	20594	1705PT	20353
170455	15497	1705AK	20714		+615599	1705PV	20353
170456	19769	1705AL	20508	1705HL	20353	1705QC	20594
170457	20090	1705AP	20296	1705HP	20571	1705QF	20594
170458	19769	1705AQ	20548	1705HQ	20587		+615599

Los nombres y números de primer equipo se utilizan solamente como referencia

IMPORTANTE:

Al pedir sistemas de escape, rogamos completen la referencia comenzando por 'MFO.' (ejemplo: 381394 → MFO.381394)

Pour commander echappement, nous vous prions de compléter la référence en commençant par MFO..

When ordering exhaust, please complete the reference by beginning with MFO..

ESCAPE / ECHAPPEMENT / EXHAUST

Fonos

OE No.	Ref.	OE No.	Ref.	OE No.	Ref.	OE No.	Ref.
Peugeot		Peugeot		Peugeot		Peugeot	
1705QG.....	20594	171727.....	615284	1717J2.....	615705	172196S.....	98752
	+615599	171728.....	615217	1717J4.....	615526	172201.....	01283
1705QJ.....	20344	171729.....	615234	1717J6.....	610576	172215.....	31503
1705QJ.....	07777	171730.....	613160	1717J7.....	613760	172217.....	615354
1705QK.....	20547	171732.....	613190	1717K0.....	613288	172218.....	01323
1705QK.....	08235	171733.....	613190	1717K4.....	613754	172261.....	01424
1705R5.....	20588	171735.....	615138	1717K8.....	610576	172275.....	1379
1705R5RP.....	07583	171736.....	615154	1717K9.....	613760	172278.....	01431
1705R6.....	21743	171737.....	615180	1717L0.....	613288	172279.....	01395
1705R6.....	08299	171738.....	613113	1717L2.....	615369	172290.....	01391
1705R7.....	21584	171739.....	613546	1717L3.....	615396	172294.....	615419
1705R8.....	21584	171743.....	613193	1717L4.....	615702	172296.....	01431
1705RV.....	20697	171744.....	613193	1717L6.....	07196	172297.....	31511
1705SF.....	20299	171745.....	615232	1717L9.....	613498	172402.....	615384
1705SF.....	07580	171748.....	615180	1717N1.....	613424	172405.....	615320
1705SK.....	20344	171749.....	615225	1717N7.....	613403	172410.....	615595
1705T7.....	21808	171750.....	615230	1717N9.....	06431	172411.....	631522
1705T8.....	20297	171752.....	613187	1717P0.....	615212	172413.....	615384
1705T9.....	19790	171753.....	613187	1717P6.....	615215	172414.....	08539
1705V0.....	20296	171754.....	613193	1717P8.....	06432	172416.....	01286
1705V3.....	20003	171755.....	613193	1717Q0.....	06433	172428.....	615294
1705V4.....	20318	171757.....	615201	1717Q1.....	08216	172434.....	615319
1705V5.....	21586	171758.....	615224	1717Q2.....	08225	172439.....	615260
1705V6.....	21586	171761.....	615223	1717Q3.....	615277	172442.....	631504
1705V8.....	21808	171766.....	613165	1717Q4.....	615618	172445.....	615352
1705V9.....	21812	171768.....	615129	1717Q5.....	613593	172450.....	615352
1705W0.....	21810	171769.....	613160	1717Q6.....	613761	172451.....	615366
1705W2.....	21581	171770.....	613165	1717Q7.....	610779	172454.....	615260
1705W4.....	21810	171771.....	01256	1717R2.....	08228	172460.....	01268
1705W7.....	613790	171772.....	615564	1717R3.....	615212	172461.....	01324
1705X6.....	20297	171774.....	613866	1717S2.....	08226	172462.....	631504
1705X7.....	20310	171775.....	613866	1717S3.....	07575	172468.....	01324
1705X9.....	21812	171777.....	615226		+07576	172471.....	615366
1705Y4.....	07172	171779.....	615129	1717S5.....	08143	172473.....	631504
1705Y9.....	21809	171780.....	613160	1717S6.....	615733	172492.....	615366
1705Z0.....	21809	171782.....	615201	1717T3.....	06433	172498.....	615515
1705Z1.....	02197	171784.....	615224	1717T4.....	08216	172548.....	615417
1705Z2.....	02641	171785.....	615226	1717V2.....	08214	172549.....	631350
1705Z3.....	02640	171786.....	615223	1717W1.....	07595	172554.....	631504
1705Z4.....	02691	171789.....	615276	1717W7.....	615802	172558.....	631232
1705Z6.....	02621	171790.....	21859	1717W9.....	615215	172564.....	31507
1705Z7.....	02674	171796.....	21859	1717WT.....	615215	172565.....	31512
1705Z8.....	20299	1717A0.....	613186	1717Z0.....	615618	172566.....	610889
1705Z8.....	07580	1717A1.....	613868	1717Z1.....	615212	172570.....	01464
1705ZR.....	07967	1717A2.....	615881	1717Z2.....	615277	172570.....	631515
1705ZS.....	20693	1717AR.....	22410	1717Z9.....	08227	172572.....	615397
170642.....	20245	1717AS.....	615811	172002.....	01282	172573.....	613913
170646.....	20296	1717AX.....	08143	172003.....	01287	172574.....	615483
170654.....	20646	1717C3.....	613187	172004.....	01357	172576.....	615515
1706A7.....	20693	1717C4.....	613187	172010.....	01302	172577.....	61235
171703.....	31520	1717C5.....	610609	172117.....	31510	172578.....	615623
171704.....	31520	1717C7.....	615368	172120.....	610888	172581.....	613490
171707.....	615281	1717CA.....	615733	172123.....	631502	172582.....	615498
171708.....	13226	1717CH.....	08215	172124.....	631502	172584.....	631522
171709.....	18027	1717CK.....	08214	172128.....	613509	172585.....	61526
171710.....	18033	1717F1.....	615369	172134.....	631502	172586.....	631515
171711.....	615138	1717F4.....	613868	172135.....	17156	172587.....	08557
171712.....	18032	1717F7.....	610605	172154.....	631502	172588.....	01492
171713.....	20754	1717F9.....	613193	172183.....	13226	172594.....	61529
171714.....	615114	1717G0.....	613193	172184.....	615327	172602.....	61531
171716.....	18038	1717H1.....	615394	172186.....	13678	172604.....	615496
171719.....	615154	1717H2.....	07595	172187.....	613225	172605.....	12694
171720.....	615512	1717H8.....	615894	172188.....	13682	172606.....	61531
171723.....	615578	1717H9.....	615894	172189.....	14205	172608.....	61592
171724.....	615158	1717HO.....	615394	172190.....	31521	172609.....	61539
171725.....	21858	1717J0.....	22410	172191.....	14216	172610.....	615381
171726.....	615564	1717J1.....	615794	172196.....	18355	172611.....	61531

Los nombres y números de primer equipo se utilizan solamente como referencia

IMPORTANTE:

Al pedir sistemas de escape, rogamos completen la referencia comenzando por 'MFO.' (ejemplo: 381394 → MFO.381394)

Pour commander echappement, nous vous prions de compléter la référence en commençant par MFO..

When ordering exhaust, please complete the reference by beginning with MFO..



ESCAPE / ECHAPPEMENT / EXHAUST

Fonos

MOTOR / MOTEUR / ENGINE

OE No.	Ref.	OE No.	Ref.	OE No.	Ref.	OE No.	Ref.
Peugeot		Peugeot		Peugeot		Peugeot	
172613	61562	1726C1	615227	1726KQ	615214	1726VX	615800
172614	61565	1726C2	615181	1726KS	615480	1726VY	615734
172616	61592	1726C3	615228	1726KT	615481	1726W1	615567
172617	61592	1726C4	615447	1726KW	615622	1726W5	61592
172620	61558	1726C5	615372	1726KX	615211	1726W7	613993
172622	61544	1726CC	615529	1726KY	613993	1726WY	615622
172624	61547	1726CN	615296	1726L6	615127	1726WZ	615211
172625	61547	1726CT	61558	1726L7	615127	1726X0	61531
172626	613226	1726CV	61544	1726L8	615290	1726X1	61565
172628	615237	1726CX	615297	1726L9	615127	1726X2	615623
172629	14218	1726CY	615299	1726LA	613423	1726X7	61531
172631	61544	1726CZ	615298	1726LE	613423	1726X8	61547
172632	61558	1726E0	615159	1726LJ	615636	1726X9	615882
172634	615499	1726E2	615584	1726LK	615636	1726Y0	615882
172635	61565	1726E3	615187	1726LL	615622	1726Y1	615883
172641	15491	1726E4	615127	1726LN	615622	1726Y2	615884
172643	615515	1726E5	613192	1726LW	610675	1726Y3	615159
172646	615505	1726E7	615504	1726LY	610849	1726Z1	61526
172649	61562	1726E8	615233	1726M0	615584	1726Z2	615181
172650	615499	1726E9	615135	1726N0	615177	1726Z3	615181
172651	615509	1726EA	615432	1726N2	615475	1726Z4	613587
172654	615514	1726EC	615828	1726N3	615221	1726Z6	610607
172655	16295	1726EE	615432	1726N5	613993	1726Z9	615828
172656	61547	1726EG	615480	1726N7	613993	172806	01463
172657	61562	1726EH	615481	1726N9	613191	172806	31514
172658	615505	1726EJ	615536	1726NA	613755	172807	01482
172659	61547	1726F6	615567	1726NE	615793	172811	08566
172661	61558	1726FH	615187	1726NG	613791	172812	01511
172662	61531	1726FJ	615187	1726NY	615884	172814	1234
172663	61592	1726FK	615584	1726NZ	615734	172815	31521
172664	61592	1726FN	615177	1726P5	615207	172817	615497
172665	61565	1726FP	615584	1726P6	615475	172822	31514
172666	61592	1726FQ	615868	1726P8	615220	172823	61528
172669	615499	1726FX	615619	1726PX	615800	172824	631349
172670	615124	1726G3	615229	1726QH	615828	172831	08532
172671	615127	1726G6	613587	1726QY	615803	172832	615533
172672	615135	1726G7	613587	1726R0	615603	172839	12443
172674	615115	1726G8	613587	1726R2	615222	172840	615495
172676	615144	1726GH	615275	1726R3	615608	172841	615494
172678	615127	1726GL	615393	1726RH	615622	172843	615644
172679	615159	1726GP	615275	1726RJ	615211	172844	615642
172680	615177	1726GV	615298	1726RK	613592	172847	814640
172685	615159	1726GY	615503	1726RX	615275	172856	61593
172686	615186	1726GZ	615547	1726RZ	615619	172857	31591
172691	613191	1726H0	613191	1726S4	615604	172863	61543
172694	615159	1726H8	615202	1726S5	615475	172864	615641
172695	61547	1726H9	615205	1726S9	615181	172865	615258
172696	615127	1726HA	613755	1726SF	615882	172866	61546
172697	615124	1726HC	610606	1726SG	615883	172867	14199
1726A2	613197	1726HE	615793	1726SH	615804	172872	615278
1726A3	613197	1726HF	610579	1726SL	615210	172873	615236
1726A4	613197	1726HG	613791	1726SN	615622	172875	19176
1726A5	613197	1726HY	615202	1726T0	615159	172878	61564
1726A6	613197	1726HZ	615703	1726T1	615227	172879	15490
1726A7	613197	1726J5	613592	1726T2	615159	172882	615284
1726A9	613197	1726J7	615207	1726T3	615181	172883	615504
1726AA	615432	1726JG	615559	1726T4	615186	172884	15486
1726AE	613197	1726JH	615828	1726T5	615409	172885	615508
1726AG	613993	1726JL	613423	1726T8	613197	172886	18041
1726AL	615207	1726JN	613423	1726TK	615211	172887	615513
1726AN	615608	1726JP	613197	1726TP	615882	172888	15498
1726AP	615604	1726JS	613423	1726TQ	615882	172889	13678
1726AQ	615205	1726K8	615127	1726V0	613197	172890	615512
1726AR	615603	1726KE	615213	1726V4	613592	172891	61546
1726AS	615372	1726KF	615213	1726V6	615205	172892	615235
1726AV	615227	1726KK	615210	1726V7	615603	172893	615111
1726C0	615181	1726KL	615211	1726VC	613993	172894	615108

Los nombres y números de primer equipo se utilizan solamente como referencia

IMPORTANTE:

Al pedir sistemas de escape, rogamos completen la referencia comenzando por 'MFO.' (ejemplo: 381394 → MFO.381394)

Pour commander echappement, nous vous prions de compléter la référence en commençant par MFO..

When ordering exhaust, please complete the reference by beginning with MFO..

ESCAPE / ECHAPPEMENT / EXHAUST



OE No.	Ref.	OE No.	Ref.
Peugeot		Peugeot	
172895	13682	1731H1	20245
172896	19176	1731H2	20245
172896S	98753	1731H7	20336
172897	615129	1731HF	20628
172898	615134	1731J2	20671
172899	613160	1731J9	20698
173101	613225	1731K7	20244
173104	815420	1731K7	07585
173112	19172	1731K8	20244
173112S	98751	1731K8	07149
173113	19173	1731K9	20255
173115	20154	1731L0	19172
173117	18355	1731L1	20628
173118	19172	1731L2	20628
173119	20669	1731L3	20558
173120	19577	1731L4	19172
173121	20096	1731L8	20649
173122	20096	1731N8	20616
173123	20091	1731N8	07953
173125	20154	1731P2	20627
173134	20328	1731P3	20674
173137	615231	1731P8	20338
173150	20091	1731P9	20337
173152	19172	1731R0	20337
173153	19172	1731R2	20586
173153RP	08138	1731R3	20628
173158	19172	1731R8	20632
173159	19172	1731S3	20628
173160	19173	1731S4	20558
173161	20154	1731T4	20556
173163	20154	1731T5	20556
173165	19172	1731T6	20337
173166	20154	1731T7	20337
173168	20096	1731T8	20338
173169	20096	1731T9	20616
173178	19172	1731T9	07953
173190	19172	1731V7	20616
173195	20255	1731V7	07953
173196	20245	1731X3	20586
1731A2	20275	1731Y1	20655
1731A3	20543	1731Z7	20632
1731A7	20669	173212B	04068
1731C7	20584	173234	615319
1731C8	20584	175008	01247
1731E1	20216	175030	615351
1731E2	20216	175594	20354
1731E3	19173	176537	07183
1731E4	20244	179171	01256
1731E4	07149	179177	01256
1731E5	20244	90603	98751
1731E5	07585	91509520	613509
1731E6	20244	95638423	31304
1731E6	07585		
1731E7	20241		
1731E8	19173		
1731EV	20558		
1731EY	20628		
1731F7	20244		
1731F7	07149		
1731F8	20241		
1731FF	20354		
1731G2	20244		
1731G2	07585		
1731G3	20244		
1731G3	07585		
1731G8	20255		
1731H0	20245		

Los nombres y números de primer equipo se utilizan solamente como referencia

IMPORTANTE:

Al pedir sistemas de escape, rogamos completen la referencia comenzando por 'MFO.' (ejemplo: 381394 → MFO.381394)

Pour commander echappement, nous vous prions de compléter la référence en commençant par MFO..

When ordering exhaust, please complete the reference by beginning with MFO..